

# Computer Sound Card Interface

## ELK-129

The ELK-129 Computer Sound Card Interface allows a computer's speaker output to be used as one of the tools for programming the ELK Recordable Modules, such as the ELK-120, ELK-124, or ELK-MV480. Includes software to download your computer's audio files (WAVs) to the Recordable Modules.



## Features

- Powers ELK-120 or ELK-124 Modules during Programming.
- Power Switch.
- Audio Jacks for Computer and Speakers.
- Plug-In Cable for Quick Connections to Recordable Modules.
- Includes 6 foot Shielded Cable for Speakers.
- Compact Plastic Case.
- Programs Recordable Modules in Seconds!
- Lifetime Limited Warranty.

## Specifications / Requirements

- Size: 4.4" x 3" x 1.15" (111.8mm x 76.3mm x 29.2mm).
- Supplies 12Volts D.C. @ 1 Amp for ELK-120 / 124 Modules.
- Requires Windows 98 or higher, Stereo Speaker Output Jack or Sound Card and computer speakers.
- Requires (1) 12V, 20VA AC Transformer (not included) to program the ELK-120 or ELK-124. Transformer is not needed for the ELK-MM447 or ELK-MV480.

Features and Specifications subject to change without notice.

PO Box 100 • Hildebran, NC 28637 • 800-797-9355 • 828-397-4200  
Fax 828-397-4415 • [www.elkproducts.com](http://www.elkproducts.com) • [info@elkproducts.com](mailto:info@elkproducts.com)

11/04 Version 4.0

**ELK**  
PRODUCTS, INC.

## 129 Overview

### APPLICATION

All ELK Voice Recordable Annunciator Modules can record & store voice, music or sound effects for later playback. There are basically two methods to record sound into the Recordable Modules; 1st is by pressing the Recordable Module's Record Switch and speaking directly into the on-board Microphone, the 2nd is to use the ELK-129 Interface to allow computer audio files such as .WAV files to be "played" and downloaded into the Recordable Module. One advantage of using an ELK-129 & computer is that unique sounds gathered from the internet or other sources can be edited and stored on a computer and then be recorded into multiple Recordable Modules at any time.

### OPERATION

This manual assumes that your computer has a functional 3.5mm stereo speaker output jack and speakers. Adjust the computer's volume to the half-way mark. The ELK-129 was originally designed for use with ELK-120 and ELK-124 version 1 Recordable Modules. Since newer Recordable Models have been added to ELK's product line, the ELK-129 operates slightly differently on these modules as described below.

### If you have an ELK-MM447 or ELK-MV480:

**You need** the ELK-129 **PLUS** an ELK-MK485 Programmer's Kit **or** ELK-MK400 Magic Module Starter Kit. Either of these two kits can be used. They contain the software needed for programming an MM447 or MV480. The ELK-129 is only required for completion of the audio connections. Refer to the instructions that are supplied with the MM447 or MV480.

**You do not need** the "Waveloader" software which is included with the ELK-129 and you do not need a Transformer for powering the ELK-129. The remainder of these instructions are also not needed, they are intended only for the ELK-120/124 Recordable Modules.

### If you have an ELK-120 or ELK-124:

**You need** the ELK-129 **PLUS** a plug-in AC step down Transformer (not included), and the "Waveloader" software which is on the CDROM included with the ELK-129. Waveloader can also be downloaded from <http://www.elkproducts.com> if needed.

A 16.5 Volt, 40VA Transformer can be used, although a 12 Volt, 20VA Transformer is recommended since it will not overdrive the ELK-129. We caution against leaving a 16.5V plugged in when the ELK-129 is not in use as it can become warm to the touch after a time.

The "Waveloader" software should be installed on a personal computer that will be used to download WAV files into the ELK-120/124 modules. Waveloader will trigger the record mode and then download (play) a computer audio file (.WAV) into the Recordable Module when the SEND button is pressed. Although not required, it is easier to download wavs to your ELK-120/124 module before field installation.

Note: If you wish to record by speaking directly in to the on-board microphone, the ELK-129 can still be utilized for providing power to the Recordable Module. However, you must unplug the cables from the AUDIO IN and AUDIO OUT jacks to prevent interference. Make certain that the on-board microphone is enabled by placing JP1 in the correct position. For example: To record a message on Channel One, place SW1 on the ELK-129 to CH1, (for ELK-120 or 124 version 2 Recordable Modules, also move DIP switch #1 to the ON position), then press and hold the RECORD push-button on the ELK-120 or ELK-124 while speaking into the built-in microphone. For Channel Two, repeat the above step, placing SW1 on the ELK-129 to CH2. (for ELK-120 or 124 version 2 Recordable Modules, also move DIP switch #2 to the ON position, and DIP switch #1 OFF).

## 129 Software Installation (ELK-120/124 ONLY)

NOTE: The following ELK-129 “Waveloader” software installation is not required for the ELK-MM447 or ELK-MV480 modules which are programmed through the Magic Module Programming Software. See previous page.

### If you have an ELK-120 or ELK-124:

Please read through the manual before starting.

To **install Waveloader**, insert the CDROM included with your ELK-129 kit into your computer’s CDROM drive. After a few moments the CD’s autorun menu should be displayed. Navigate to the “Software” screen and click the “Install Waveloader” button to install the software program to your computer. The setup program will guide you through the installation. Normally, you should choose the default directory suggested by setup, but you may change the drive and / or directory, if needed. Once setup has finished, find the new program icon labeled “Waveloader” on your desktop screen.

To test **Waveloader**, click on the Waveloader icon, then click the **File** button, you should see the Channel 1 and Channel 2 default audio message files listed. Click on one of these files and then click **OPEN**. Note: Do not use or delete the 20hz.wav file, it is needed for proper waveloader operation. Click on the **Play** button to hear the file. If you do not hear the file playing from your computer’s speakers, check the computer’s volume settings. If your computer came with a “mixer” program, make sure all of the sliders or knobs are turned up and no outputs are muted. If you have determined that the volume control is turned up and you still don’t hear the file when you click on **Play**, check to make sure your speaker cable is plugged into the correct jack on the computer and on the speakers themselves. Also, make sure the speakers are turned on (amplified speakers only), and that their volume is turned up. Make sure speakers are connected to a power adapter (and that the adapter is plugged into the AC). You can close the program for now.

## ELK-120 / 124 Versions 1 & 2 Hardware

### ELK-120/124 Versions 1 & 2 Channel Activations as related to the ELK-129 Operation:

This section describes how channels are activated (triggered) on various Recordable Modules. A channel must be activated (playing) to accept a new recording. Channels on version 1 modules can be activated by using SW1 on the ELK-129. Version 2 modules use SW1 in addition to DIP Switches to activate the desired channel to be recorded.

- **ELK-120 V1** Original version featuring 2 Voice Channels of 10 seconds each.  
Turn SW1 to CH1 to activate Channel 1 or to CH2 to activate Channel 2.
- **ELK-120 V2** Version 2 featuring 4 Voice Channels of 120 seconds each and DIP switches to select channel to be recorded.  
Turn SW1 to CH1 to power the module, then move any DIP Switch to the ON position to activate a corresponding channel.
- **ELK-124 V1** Original version featuring 4 channels of 30 seconds each.  
Place ribbon cable on J1, move SW1 to CH1 to record Channel 1 or move SW1 to CH2 to record Channel 2.  
Place ribbon cable on J2, move SW1 to CH1 to record Channel 3 or move SW1 to CH2 to record Channel 4.
- **ELK-124 V2** Version 2 featuring 8 channels of 60 seconds each. Set Channel Polarity jumpers to “+”. Turn SW1 to CH1 to power the module, then move any DIP Switch to the ON position to activate a corresponding channel.

## Recording Hookup (ELK-120/124 ONLY)

The recording hookup requires the following supplied items:

- 1 - ELK-129 module.
- 1 - 1 foot, 5-pin ribbon cable.
- 1 - 6 foot shielded audio cable.

You will need the following items, which are not supplied:

- 1 - 12 Volt, 20VA step down AC transformer.
- 1 - Length of 2-conductor (zip cord) wire for connection of the transformer.
- 1 - Windows based computer with 16-bit stereo speaker output jack, speakers, and some audio files. (.WAV)
- 1 - Recordable Module. (ELK-120 or ELK-124)
- 1 - 8 ohm (15-30 watts recommended) speaker for playback of the recorded messages. (if desired)

Refer to Figure 1 when making the following connections:

1. Strip the ends of the 2-conductor wire and connect one end to the step down transformer and the other end to the AC terminals on the ELK-129 (located under the cover). Plug the transformer into an AC receptacle. To confirm the power connection to the ELK-129, move the power switch to CH1 and look for the Power Led "ON". Return SW1 to the center "OFF" position.
2. **Always be sure SW1 is off before making any connections to the ELK Recordable Module or the ELK-129 interface.** Plug the 5-pin ribbon cable onto the polarized connector J1 on the ELK-129. Plug the other end onto the Programmer input of the Recordable Module. (Refer to the Recordable Module's instruction manual for programmer input location)
3. Remove the audio cable from the back of the computer speakers and plug it into the **AUDIO IN** Jack on the ELK-129. Plug one end of the supplied 6-foot shielded audio cable into the **AUDIO OUT** Jack. Plug the other end of this cable into the computer speakers, where the first cable was originally plugged. If your speaker cable is wired directly to the speaker with no jack, plug the speaker cable into **AUDIO OUT** and connect the 6-foot shielded cable between the computer and **AUDIO IN**.
4. Connect a speaker (8 ohms, 15-30 watts recommended) to the speaker terminals of the Recordable Module. **Adjust the module's volume control to a minimum level before turning on the ELK-129.**
5. When programming an audio file from the computer, into the Recordable Module, make sure to **disable the on-board microphone** on the Module. Refer to the Recordable Module's instruction sheet for location of the on-board microphone jumper. Make sure your computer's microphone is either off, unplugged, or muted. This will prevent room noises from being recorded along with your messages. Make sure jumper **JP2** is set to "**Repeat**" mode (single play disabled).
6. To prevent short circuits, keep the units away from metal surfaces while power is applied. To prevent electrical noise (EMI) from being induced into the recording, keep the Recordable Module and the ELK-129 as far away as possible from sources of electrical noise such as video monitors and transformers.
7. Place **SW1** on the ELK-129 to the **CH1** position. For ELK-120 or 124 version 2 Recordable Modules, also move **DIP switch #1** to the ON position. Adjust the Recordable Module's volume control until you hear the default channel 1 message playing at a comfortable level. If channel 1 has been erased, you may not hear anything at all.
8. Once you have confirmed that the Recordable Module and the ELK-129 are properly connected, you are ready to begin the WAV downloading process (you may turn off CH1 or DIP sw #1 for now).

# Hookup (ELK-120/124 ONLY)

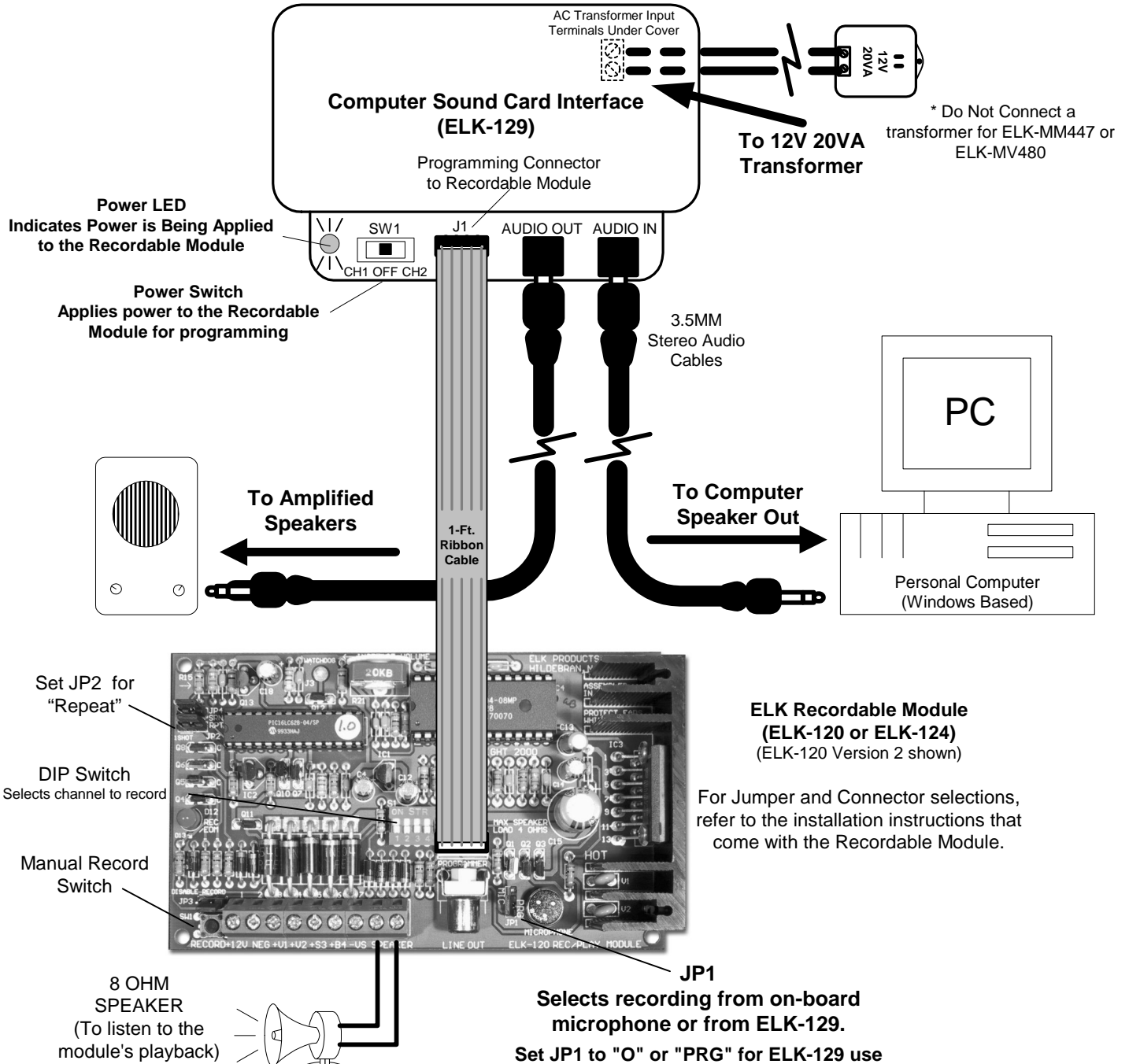

Figure 1.

## Programming (ELK-120/124 ONLY)

**NOTE:** This section explains how to program an ELK-120 or ELK-124. For other ELK Recordable Modules models, please refer to the installation instructions that accompany the Recordable Module.

If you have completed the hookup and software installations, you are ready to program your first unit.

In the following steps, you will use the factory default ELK-120 Channel 1 and Channel 2 .WAV files (supplied by the setup program) or use your own audio files to help setup the proper computer volume levels. The Waveloader program will be used to download wav files into the recordable module.

1. Click on the **Waveloader** icon, then click on the **File** button. In the **OPEN** window, click on the **Channel 1.wav** file, then click on **OPEN**.
2. Adjust your computer's volume to the half-way mark. Use **PLAY** to preview the WAV file and use **SEND** to download the WAV file.
3. You must apply power to a channel in order to record it. Channels are activated differently depending on which version of Recordable Module you have as noted below.



Figure 2.

- 4a. For ELK-120 Version 1 Modules, (has no dip switch) .. skip to step 5.
- 4b. For ELK-120 Version 2 Modules, (has dip switch) ... Move DIP Switch #1 to the ON position .. skip to step 5.
- 4c. For ELK-124 Version 1 Modules, (has no dip switch) ... skip to step 5.
- 4d. For ELK-124 Version 2 Modules, (has dip switch) ... Move DIP Switch #1 to the ON position .. skip to step 5.
5. Be sure you have a 12 volt AC Transformer connected to the ELK-129. Turn **SW1** on the ELK-129 to **CH1**. Channel 1's message should start playing. In Waveloader, click on the **SEND** button to start sending Channel 1.wav. You should hear your file playing from the computer speakers. If the computer's volume level is high enough, the RECORD / EOM LED on the Recordable Module should come on solid, indicating the message is being recorded. The Recordable Module will playback the message just recorded.
6. If the RECORD / EOM LED does not come on solid while Waveloader is sending the file, you will need to increase your computer's volume output before trying again. If your volume is already set to maximum, be sure you are using the computer's speaker output jack instead of a line output jack. If the RECORD / EOM LED still doesn't come on, try **manually** pressing the Recordable Module's **RECORD** switch and click on **PLAY** at the same time. If this works, you may have to use this manual method when programming. If the manual method does not work, then there may be a problem in the hookup or with one of the units.
7. If the Recordable Module's message sounds distorted during playback, try reducing your computer's volume control and repeating step 5. You can normally double-click the small speaker icon in the task bar to adjust the volume. To reduce distortion, use the lowest volume setting that will trigger the Recordable Module.
8. When you have successfully programmed the message for Channel 1, you may proceed to program Channel 2 by placing SW1 on the ELK-129 to the CH2 position. For ELK-120 or 124 version 2 Recordable Modules, also move DIP switch #1 to the OFF position, then turn DIP Switch #2 to the ON position. Repeat Steps 1-7, loading the file Channel 2 wav instead of the Channel 1 wav.
9. Once you have mastered the downloading process, try downloading some of your own WAV files or try recording your own WAV files using the Windows Sound Recorder and a microphone. Use care to prevent overrunning the Recordable Module's recording time limit.
10. After field installation, the ELK-120/124 selection jumpers should be set for the desired operation. i.e. disable record switch, repeat / 1shot mode, DIP switches OFF, and the channel polarity jumpers on the ELK-124 v2.