

# Concord 4 Installation Manual



P/N 466-2182 • REV K • ISS 11AUG16

<b>Copyright</b>	<p>© 2016 UTC Fire &amp; Security Americas Corporation, Inc. Interlogix is part of UTC Climate Controls &amp; Security, a unit of United Technologies Corporation. All rights reserved.</p> <p>This document may not be copied in whole or in part or otherwise reproduced without prior written consent from UTC Fire &amp; Security, Inc., except where specifically permitted under US and international copyright law.</p>
<b>Disclaimer</b>	<p>The information in this document is subject to change without notice. UTC Fire &amp; Security assumes no responsibility for inaccuracies or omissions and specifically disclaims any liabilities, losses, or risks, personal or otherwise, incurred as a consequence, directly or indirectly, of the use or application of any of the contents of this document. For the latest documentation, contact your local supplier or visit us online at <a href="http://www.utcfireandsecurity.com">www.utcfireandsecurity.com</a>.</p> <p>This publication may contain examples of screen captures and reports used in daily operations. Examples may include fictitious names of individuals and companies. Any similarity to names and addresses of actual businesses or persons is entirely coincidental.</p>
<b>Trademarks and patents</b>	<p>Other trade names used in this document may be trademarks or registered trademarks of the manufacturers or vendors of the respective products.</p>
<b>Intended use</b>	<p>Use this product only for the purpose it was designed for; refer to the data sheet and user documentation for details. For the latest product information, contact your local supplier or visit us online at <a href="http://www.utcfireandsecurity.com">www.utcfireandsecurity.com</a>.</p>
<b>Contact information</b>	<p><a href="http://www.utcfireandsecurity.com">www.utcfireandsecurity.com</a>. or <a href="http://www.interlogix.com">www.interlogix.com</a></p>
<b>Technical support</b>	<p><a href="http://www.interlogix.com/customer-support">www.interlogix.com/customer-support</a>.</p>

# Content

Important information	iii
<b>Chapter 1 Introduction</b>	<b>1</b>
Planning the installation	2
SuperBus 2000 bus devices	3
<b>Chapter 2 Installation</b>	<b>5</b>
Installation overview	6
Mounting the panel	10
Intrusion detection devices	15
Smoke detectors	15
Speakers and sirens	18
SuperBus 2000 touchpads	22
SuperBus 2000 modules	22
Phones	28
Power	30
<b>Chapter 3 Programming</b>	<b>33</b>
Overview	34
Quick programming mode	36
Tier 1 programming menus	37
Tier 2 programming menus	40
Security menu	45
Phones menu	50
Phone options menu	54
Timers menu	57
Light control menu	59
Touchpad options menu	60
Reporting menu	61
Siren options menu	66
Sensors menu	67
Audio verification menu	71
Accessory modules menu	73
Onboard options menu	78
Macro keys menu	81
User programming mode	82
Downloader programming	93
<b>Chapter 4 Testing and troubleshooting</b>	<b>95</b>
Testing the system	96

Troubleshooting 106

**Appendix A System planning sheets 117**

Customer information 118

Wireless devices 118

Hardware devices 119

Zone and sensor assignments 121

System settings index and record 124

**Appendix B Reference tables 129**

Sensor group characteristics 130

Sensor text 134

System event triggers 136

Sensor group event triggers 137

Sensor number event triggers 138

System feature event triggers 141

Response characteristics 143

Response numbers 143

Specifications 145

# Important information

## Intended use

Use this product only for the purpose it was designed for; refer to the data sheet and user documentation for details. For the latest product information, contact your local supplier or visit us online at [www.utcfireandsecurity.com](http://www.utcfireandsecurity.com).

Changes or modifications not expressly approved by UTC Fire & Security can void the user's authority to operate the equipment.

## About this manual

This manual provides information for planning, installing, programming, and testing this security system. Planning sheets are included for you to record hardware layout and software programming settings.

Use this manual for the following panels:

600-1021-95R	Concord 4 RF
600-1022-95R	Concord Express V4
600-1040	Concord Commercial V4
600-1042	Concord Hybrid

When necessary, this manual refers you to other documentation with compatible peripherals.

The *Concord 4 User Manual* (P/N 466-2183) contains user worksheets that you should fill out during the installation and programming of the system. For multiple-partition systems, we suggest a user manual for each partition.

Read these instructions and all related documentation entirely before installing or operating this product.

**Note:** A qualified service person, complying with all applicable codes, should perform all required hardware installation.



# Chapter 1

# Introduction

## **Summary**

This chapter provides information to help you plan your Concord 4 panel and system installation.

## **Content**

Planning the installation	2
Standard panel	2
SuperBus 2000 bus devices	3

## Planning the installation

This section describes system capabilities to help you get familiar with the system. Appendix A “System planning sheets” on page 117 provides planning sheets that let you record the hardware and programming configuration of the system. Fill in all necessary information ahead of time to help prepare for system installation.

### Standard panel

Table 1 below shows the standard panel capabilities.

**Table 1: Panel capabilities**

Capabilities	Concord Express v4	Concord 4/Concord Commercial v4
Zones	32	96
Partitions	2	6
Bus devices	16	16
User codes	16	230

Table 2 describes the basic panel (out-of-box) hardware capabilities for all panels.

**Table 2: Basic panel hardware capabilities**

Power	Input for an AC step-down, plug-in style transformer.
Auxiliary power output	Output that supplies 9 to 14 VDC with up to 1 amp for bus devices and hardwired detectors, such as smoke and motion detectors.
Bus A and B	Input and output that provides communication between bus devices and the panel.
Siren driver	Output that can drive an 8-ohm load and provides intrusion and fire alarm sounds for partition 1 (15 watts maximum).
Two onboard outputs	Can be used to activate other signaling devices based on system events. Out 1 is a 9 to 14 VDC source output, limited to 1.0 amp max. Out 2 is an open-collector output, rated up to 14 VDC, 300 mA max
Microphone input	Input used for 2-way audio when used in conjunction with the Interrogator 200 audio verification module.
Eight supervised hardwired zones	Inputs for various hardwired detectors. Zone 8 can be set up in programming to accept two-wire smoke detectors. It sources 9 to 14 VDC, 90mA max.



Built-in RF receiver	Allows use of up to 96 (Concord 4) or 32 (Concord Express v4) 319.5 MHz. crystal and/or SAW learn mode wireless sensors and touchpads.
Phone line connection	Allows panel to communicate with central monitoring station and/or pagers.

## SuperBus 2000 bus devices

The following components can be used with the Concord 4 panel:

**Table 3: SuperBus devices**

Touchpads	<p>Use the following touchpads for installer/user programming and system operation.</p> <ul style="list-style-type: none"> <li>• SuperBus 2000 2x16 LCD touchpad</li> <li>• SuperBus 2000 2x20 LCD touchpad</li> <li>• SuperBus 2000 2x20 VFD touchpad</li> <li>• SuperBus 2000 ATP 1000 touchpad</li> <li>• SuperBus 2000 ATP 2100 touchpad</li> <li>• SuperBus 2000 ATP 2600 touchpad</li> </ul> <p>Use the following touchpads for installer quick programming, system operation and user programming:</p> <ul style="list-style-type: none"> <li>• SuperBus 2000 fixed display touchpad</li> <li>• SuperBus 2000 FTP 1000 touchpad</li> </ul>
SuperBus 2000 RF transceiver	Use the transceiver to receive signals from sensors and touchpad that may be on the fringe of panel reception. The transceiver is compatible with all 319.5 MHz crystal and SAW learn mode wireless sensors and touchpads.
Power line carrier transformer	Allows the use of X10 powerhouse lamp modules for light control and light activation during alarms.
SuperBus 2000 voice only module	Provides an output for a speaker that sounds system status and alarm voice messages.
SuperBus 2000 phone interface/voice module	Allows system access and control using touchtone telephones, onsite or offsite. The module includes an output for a speaker that sounds system status and alarm voice messages

SnapCards

The following SnapCards expand the system as described:

8Z input Snapcard: Provides eight additional hardwired zone inputs, of which two are dedicated for using two-wire smoke detectors.

4 output SnapCard: Provides four form C relay outputs that can be set up to activate other signaling devices, based on system events, schedules, or direct control.

4Z input/output combo SnapCard: Provides three hardwired zone inputs, one two-wire smoke detector loop, and two outputs that can be set up to activate other signaling devices, based on system events, schedules, or direct control.

SuperBus 2000 8Z input module (HIM)	Provides eight additional hardwire zone inputs.
SuperBus 2000 four-relay output module (HOM)	Provides four form C relay outputs that can be set up to activate other signaling devices, based on system events.
Interrogator 200 audio verification module	Allows central station operators to listen in and talk to occupants on the premises to verify the emergency when an alarm report is received.
SuperBus 2000 energy saver module (ESM)	Provides a money-saving and convenient way to monitor and control temperatures. The ESM uses low- and high-temperature limits to save energy by overriding the existing HVAC thermostat.
SuperBus 2000 automation module	Provides a connection to a compatible home automation device.
SuperBus 2000 wireless cellular gateway	Allows users to control and monitor the status of their system from the alarm.com internet website.
SuperBus 2000 2-amp power supply	Provides an additional 12 VDC, 2 amps for powering system devices and is supervised via the panel data bus.

# Chapter 2

# Installation

## Summary

This chapter provides information on locating and installing the panel and system components.

## Content

**Error! Bookmark not defined.**

## Installation overview

Before starting the installation, plan your system layout and programming using the worksheets provided in Appendix A “System planning sheets” on page 117.

**Note:** Class 2, Class 3, and power-limited fire alarm circuits must be installed using FPL, FPLR, FPLP, or substitute cable permitted by the National Electrical Code ANSI/NFPA 70 or Class 2, Class 3, and power-limited fire alarm circuit conductors must be installed as Class 1 or higher circuits.

**Note:** Class 2, Class 3, and power-limited burglar alarm circuits must be installed using CL2, CL2R, CL2P, or substituting cable permitted by ANSI/NFPA 70. Wire that extends beyond the cable jacket must be separated from all other conductors by a minimum of 0.25 in. or by a nonconductive barrier.

Use the following installation guidelines:

- Centrally locate the panel with relation to detection devices whenever possible, to help reduce wire run lengths and labor.
- Locate the panel where the temperature will not exceed 120°F (49°C) or fall below 32°F (0°C).
- Avoid running wires parallel with electrical wiring or fixtures such as fluorescent lighting, to prevent wire runs from picking up electrical noise.
- Mount the panel at a comfortable working height (about 45 to 55 in. from the floor to the bottom of the panel, as shown in Figure 1 on page 7).
- Leave space to the left and right of the panel for wiring, phone jack, and mounting optional modules. Allow at least 9 in. (23 cm) above the panel cabinet for antennas. Allow at least 24 in. (62 cm) in front of the panel to open the panel door.

Figure 1: Panel and component locations on a wall

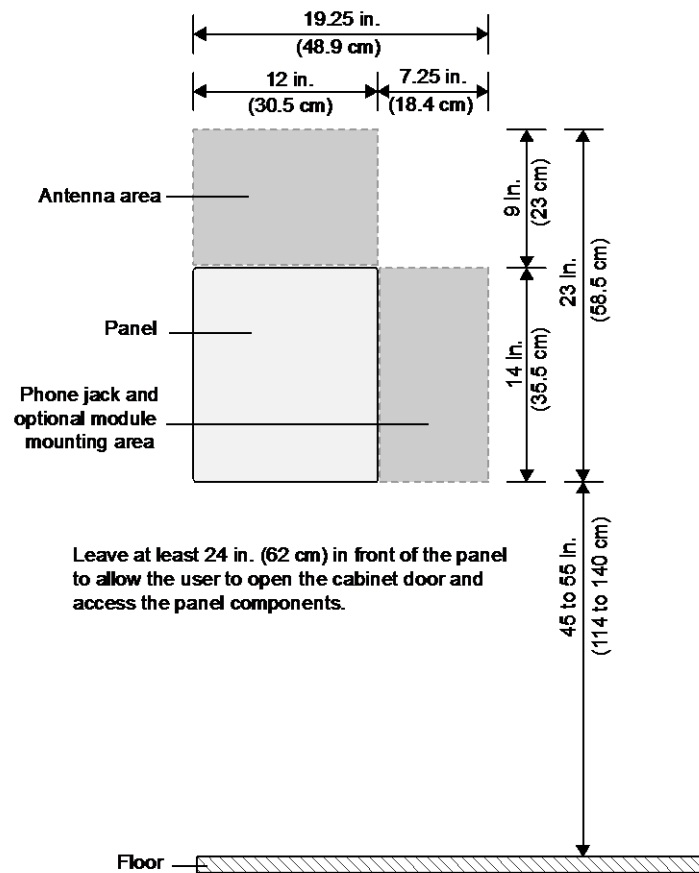

## Total system power and wire length guidelines

The panel can supply up to 1 amp (1,000 mA) in full load alarm condition for system devices connected to panel terminals 4 (+12V), 7 and 8 (speaker terminals), 9 (OUT1), 11 (+12V), 24 (2W SMK ZONE 8), and SnapCard terminals.

For 24-hour backup, the total standby current draw for all devices connected to panel terminals 4 (+12V), 9 (OUT1), 11 (+12V), 24 (if configured for 2-wire smoke loop), and SnapCard terminals is limited to 90 mA (during normal standby condition) using a 4.5 or 5.0 Ah battery, or 190 mA (during normal standby condition) using a 7.0 Ah battery.

The total system wire length allowed can vary depending on devices powered by the panel, the wire length between devices and the panel, and the combined wire length of all devices.

Table 4 below describes the maximum wire length allowed between compatible devices and the panel, and the minimum and maximum current draw of each device.

**Table 4: Wire length requirements**

Device	Max. wire length to panel	Standby mA draw	Alarm mA draw
SuperBus 2000 2x16 LCD alphanumeric touchpad	22 ga.: 300 ft. 18 ga.: 750 ft.	15 mA	90 mA
SuperBus 2000 ATP 1000 alphanumeric touchpad	22 ga.: 300 ft. 18 ga.: 750 ft.	12 mA	110 mA
SuperBus 2000 ATP 2100 alphanumeric touchpad	22 ga.: 300 ft. 18 ga.: 750 ft.	30 mA	165 mA
SuperBus 2000 ATP 2600 alphanumeric touchpad	22 ga.: 300 ft. 18 ga.: 750 ft.	30 mA	165 mA
SuperBus 2000 fixed display touchpad	22 ga.: 300 ft. 18 ga.: 700 ft.	11 mA	65 mA
SuperBus 2000 FTP 1000 fixed display touchpad	22 ga.: 300 ft. 18 ga.: 700 ft.	12 mA	75 mA
SuperBus 2000 RF transceiver	22 ga.: 1,000 ft. 18 ga.: 2,500 ft.	45 mA	55 mA
SuperBus 2000 phone interface/voice module	22 ga.: 40 ft. 18 ga.: 120 ft.	25 mA	600 mA
SuperBus 2000 voice-only module	22 ga.: 40 ft. 18 ga.: 120 ft.	20 mA	300 mA (jumper) 600 mA (no jumper)
SuperBus 2000 2 amp power supply		No load	No load
4 input/2 output SnapCard	N/A	20 mA	185 mA*
8Z hardwired zone expander SnapCard	N/A	38 mA	230 mA*
4 output SnapCard	N/A	1 mA	130 mA*
SuperBus 2000 8Z input module	22 ga.: 1,800 ft. 18 ga.: 4,000 ft.	18 mA	35 mA
SuperBus 2000 4-relay output module	22 ga.: 350 ft. 18 ga.: 900 ft.	12 mA	180 mA

Device	Max. wire length to panel	Standby mA draw	Alarm mA draw
SuperBus 2000 energy saver module	22 ga.: 1,600 ft. 18 ga.: 4,000 ft.	20 mA	20 mA
SuperBus 2000 automation module	22 ga.: 1,500 ft. 18 ga.: 4,000 ft.	30 mA	35 mA
SuperBus 2000 wireless cellular gateway	22 ga.: 40 ft. 18 ga.: 90 ft.	65 mA	1600 mA
Interrogator 200	22 ga.: 3,200 ft. 18 ga.: 4,500 ft.	10 mA	10 mA
Interrogator AVM	22 ga.: 110 ft. 18 ga.: 260 ft.	45 mA	300 mA
Two-wire smoke detectors (ESL 429AT, 429C, 429CT, 521B, 521BXT, 521NCSXT)	22 ga.: 330 ft. 18 ga.: 330 ft.	70 $\mu$ A	60 mA
Two-wire smoke detectors (system sensor 2400, 2400TH)	22 ga.: 330 ft. 18 ga.: 330 ft.	120 $\mu$ A	80 mA
Hardwired interior siren (13-949)	22 ga.: 750 ft. 18 ga.: 1,500 ft.	0 mA	85 mA
Piezo dynamic exterior siren (13-950)	22 ga.: 750 ft. 18 ga.: 1,500 ft.	0 mA	150 mA
Speaker siren (60-528 or 13-060)	18 ga.: 100 ft.	0 mA	500 mA

\*Maximum current draw for the SnapCards does not include the load which may be applied to their auxiliary DC supply.

Table 5 below describes the total system wire lengths allowed for all SuperBus 2000 devices when installing systems using unshielded or shielded cable. After determining panel location, run all necessary wires to that location using the information in Table 6 on page 10.

**Table 5: Wire lengths**

Wire type	Total system wire
18-gauge, unshielded	4,000 ft.
18-gauge, shielded	3,000 ft.

Wire type	Total system wire
22-gauge, unshielded	4,000 ft.
22-gauge, shielded	3,000 ft.

**Table 6: Device wire requirements**

Device	Wire requirements
AC power transformer	2-conductor, 18-gauge, 25 ft. max.
Earth ground	Single conductor, 16-gauge solid, 25 ft. max.
Telephone (RJ-31X)	4-conductor
Detection devices	2- or 4-conductor, 22-gauge, 1,000 ft. max. 2- or 4-conductor, 18-gauge, 2,500 ft. max. (based on 30 ohms max. loop resistance including device)
Speakers	2-conductor, 18-gauge, 100 ft. max.
SuperBus 2000 devices	4-conductor, 22- or 18-gauge
Interrogator 200 AVM power and microphone	4-conductor, 22-gauge, shielded
2-wire smoke detectors	2-conductor, 22-gauge, 330 ft. max. 2-conductor, 18-gauge, 830 ft. max.

## Mounting the panel

Mount the panel to the wall or wall studs.

**Caution:** Make sure you are free of static electricity whenever you work on the panel with the cover open. To discharge any static, first touch the metal panel chassis, and then stay in contact with the chassis when touching the circuit board. We recommend using a grounding strap.

### To mount the panel:

1. Remove the panel door and remove the necessary wiring knockouts. Be careful not to damage the circuit board.
2. Feed all wires through wiring knockouts and place the panel in position against the wall.
3. Level the panel and mark the top and bottom mounting holes (see Figure 2 on page 11).
4. Install anchors where studs are not present.



5. Partially insert screws into the two top mounting hole locations, then hang the panel on the two screws.
6. Recheck for level, insert the two lower screws, and tighten all four mounting screws.

**Figure 2: Panel components and mounting holes**

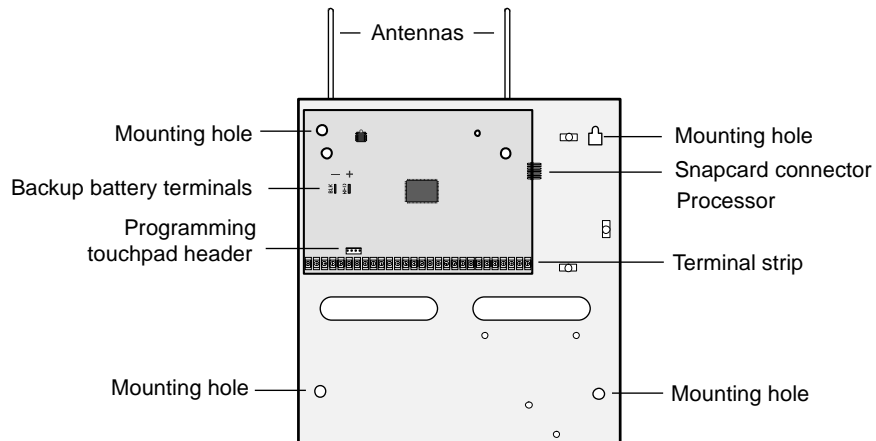

## Grounding the panel

For maximum protection from lightning strikes and transients, connect the enclosure to earth ground as shown in Figure 3 below. Use 16-gauge, solid copper wire from an earth grounded cold water pipe clamp to the enclosure.

**Figure 3: Grounding the panel**

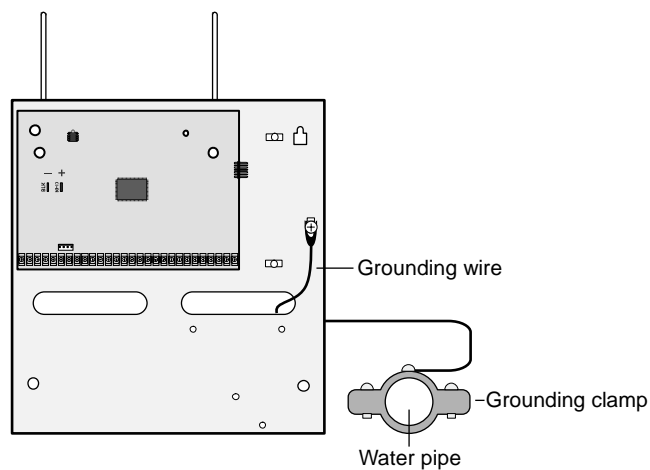

**Note:** For best results, we recommend that you crimp a spade lug on the wire end at the panel and secure the lug to the enclosure.

## Antenna shrouds

Install a plastic antenna shroud (included with panel) over each antenna and snap them into the holes on the top of the enclosure (skip this step for hybrid and commercial systems).

## Optional SnapCards

Use the SnapCard header on the right side of the panel (Figure 4 below) to install an optional SnapCard. Install the SnapCard onto the panel SnapCard header and secure it in place with two screws, included with the SnapCard. To connect all necessary input/output wiring, refer to the SnapCard documentation.

**Figure 4: Installing a SnapCard**

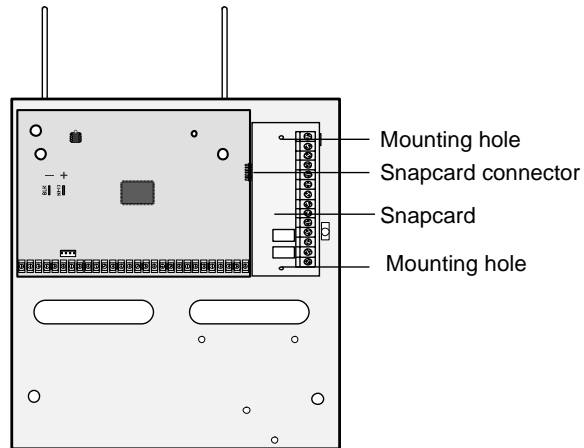

## Panel terminals

Figure 5 below shows an overview of panel terminals. The following sections provide details on how to connect devices to the panel.

**Figure 5: Panel terminals**

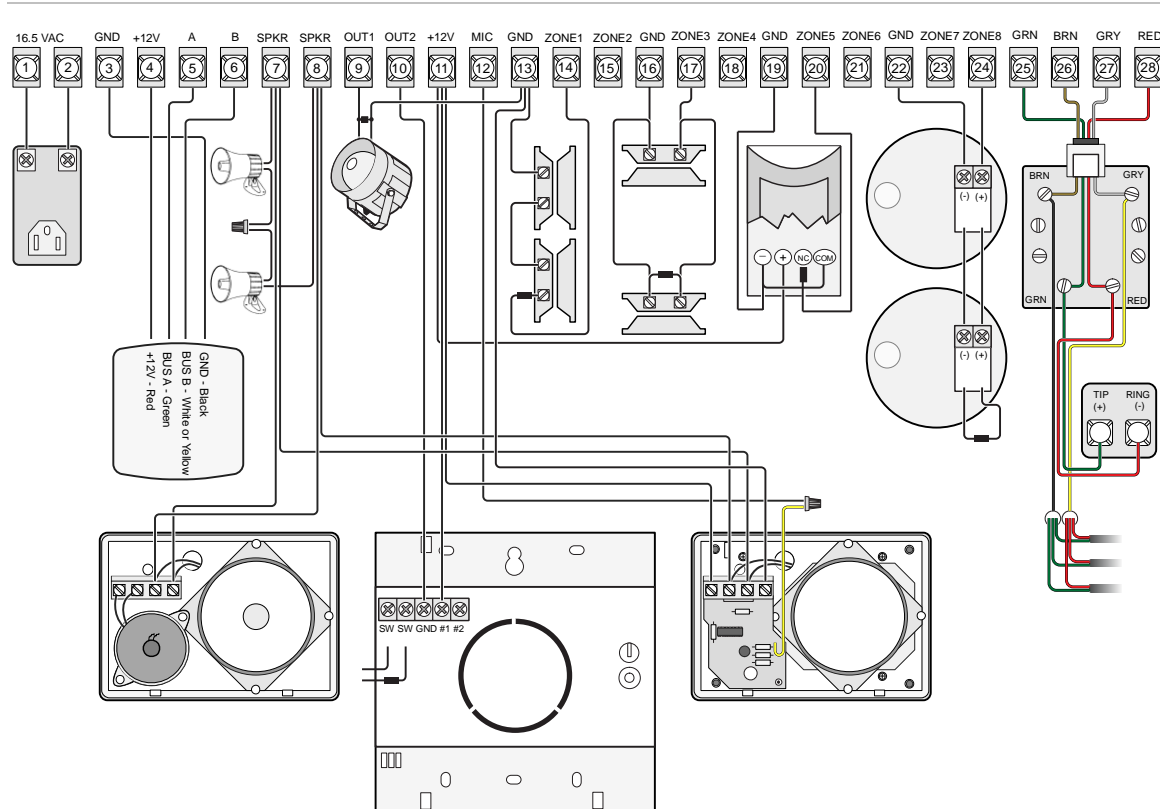

## Zones

The panel comes with factory programmed onboard hardwired zones. Install 2 kohm, end-of-line (EOL) resistors on all unused factory programmed onboard hardwired zones. If you don't want to install EOL resistors, delete any unused zones from memory.

Zone inputs 1 through 8 are supervised using the included 2-kohm, end-of-line resistors at the last device on each circuit. All eight zones accept either normally open (NO) or normally closed (NC) detection devices.

## Intrusion detection devices

Figure 6 below shows the typical wiring for NC and NO door/window intrusion detection and the typical wiring for a PIR motion detector. The minimum available panel voltage for hardwired PIR motion detectors is 8.5 VDC.

**Figure 6: Connecting intrusion detection and motion detector circuits**

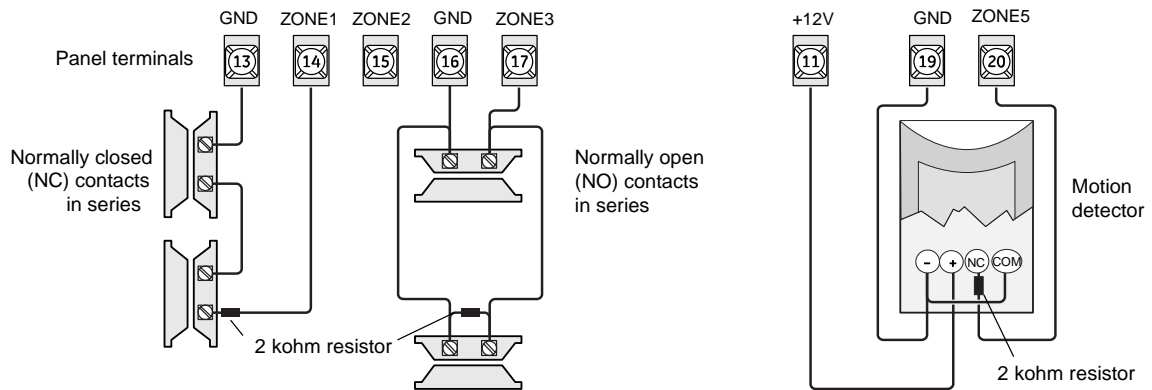

## Smoke detectors

You can connect two-wire and four-wire smoke detectors to the system.

### Two-wire smoke detectors

Zone input 8 can be set up (in program mode) to accept the following 12 VDC, two-wire smoke detectors:

ESL models 429AT, 429C, 429CT, 521B, 521BXT, 521NCSXT (models 521B and 521BXT require the following dip switch settings: 1-on, 2-off)

**Caution:** Use only the two-wire smoke detector models listed. Alarm signals from other detectors may not process correctly if the panel loses AC power and is operating only from the backup battery.

When set up for two-wire smoke detectors, zone 8 can handle up to 20 smoke detectors (all of the same model, as listed above) with 120 uA maximum idle current per detector. Maximum total loop current allowed in an alarm condition is 90 mA. Connect one or more, two-wire smoke detectors to the panel as shown in Figure 7 on page 16.

**Note:** When using two-wire smoke detectors on zone 8, the two-wire smoke setting (in program mode) must be turned on *before* entering the learn sensors menu.

**Figure 7: Connecting two- and four-wire smoke detectors**

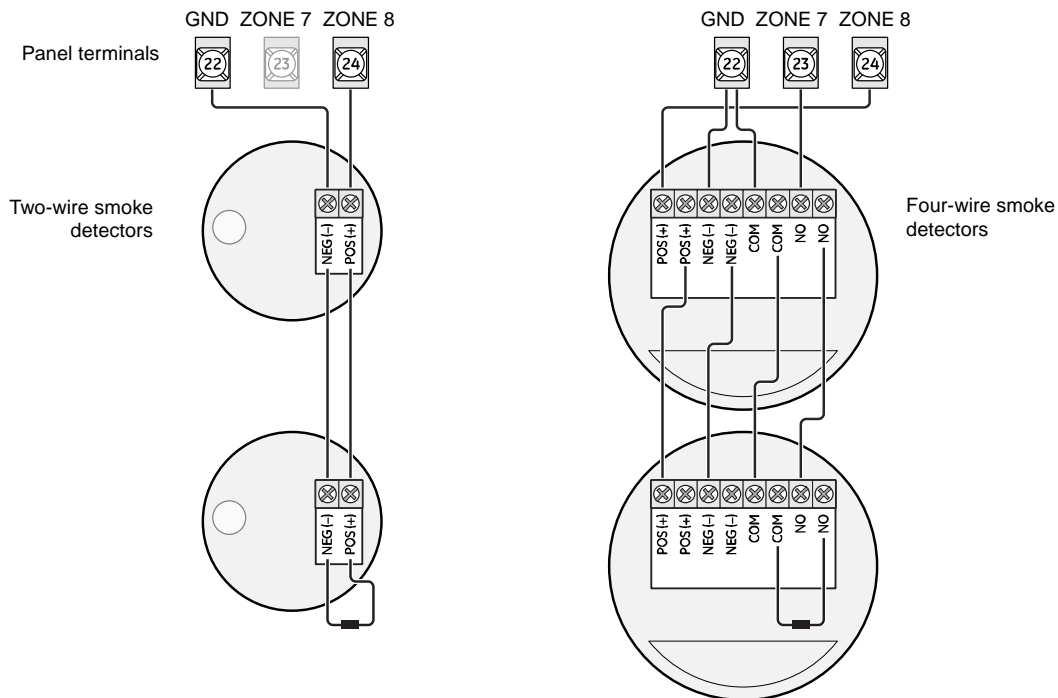

**Note:** The two-wire smoke setting (in program mode) must be on when using four-wire smoke detectors as shown in Figure 7 above. See “Onboard options - inputs settings” on page 78 for complete details.

If two-wire smoke detectors with built-in sounders are used (521INCSXT), a polarity reversal relay (model 405-03) may be used to activate the sounders on all smoke detectors during a fire alarm (see Figure 8 on page 17). An output must be used to activate the polarity reversal relay. This output must be configured for fire alarm trigger, and siren tracking response (001-11).

**Note:** Onboard outputs 1 or 2, SnapCard outputs, or output module outputs may be used to activate the polarity reversal relay.

Maximum alarm current that the panel can source to all external devices is limited to 1 amp. Be sure to include the alarm current for all sounder smoke detectors in the alarm current calculation.

Figure 8: Polarity reversal module

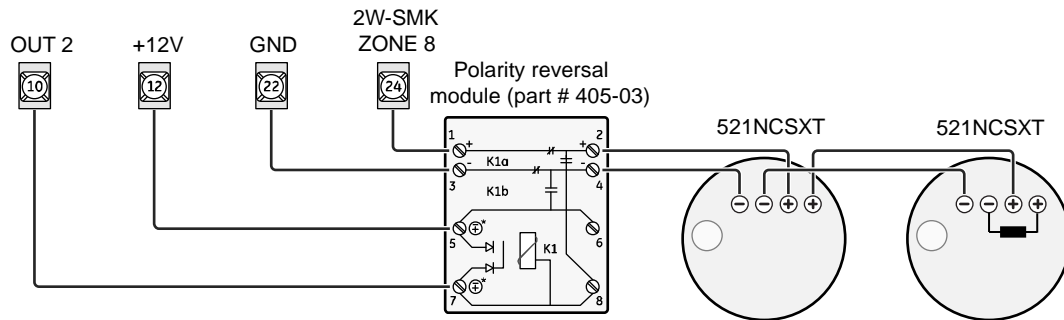

## Four-wire smoke detectors

Terminal 24 provides power to four-wire smoke detectors that latch and remain in the alarm state until power turns off, then restores to the detector. The panel provides this power interruption from terminal 24 (2W SMK ZONE 8) only when the two-wire smoke option is on.

**Note:** The two-wire smoke feature must be on for smoke detectors to reset after canceling a fire alarm.

Table 7 below describes the minimum available panel power. Use only four-wire smoke detectors that operate at these power limits. Connect up to five smoke detectors as shown in Figure 7 on page 16.

**Table 7: Minimum available panel power**

Minimum voltage	Maximum current available
8.3 VDC	Up to 30 mA total (combined alarm) current
8.1 VDC	Up to 40 mA total (combined alarm) current
7.6 VDC	Up to 60 mA total (combined alarm) current
7.1 VDC	Up to 80 mA total (combined alarm) current

## Speakers and sirens

The panel provides one siren driver output for intrusion (steady), fire (temporal 3), and auxiliary (on-off-on-off) alarm sounds. This output trips only for partition 1 alarms. Install all sirens/speakers indoors in a concealed location.

**Note:** Do not connect a bell or piezo siren to the speaker output (terminals 7 and 8).

The output can drive a single 8-ohm speaker or a multiple speaker circuit of 8 ohms or higher. When connecting two or more speakers, wire them in series. Wiring speakers in parallel can permanently damage the panel. Compatible speakers are shown below.

**Caution:** To avoid disabling the panel speaker output, do not make speaker connections with the panel power on.

### 15-watt speaker (13-060)

For exterior siren applications, connect the speaker to the panel using 18-gauge wire as shown in Figure 9 below.

**Figure 9: Connecting exterior speakers**

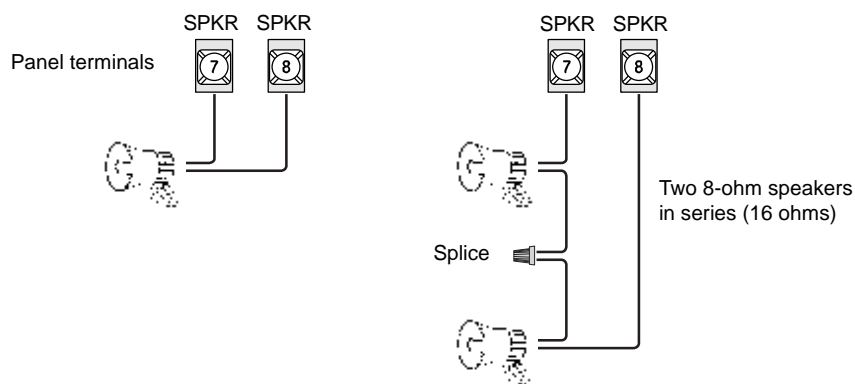

### Hardwired interior speaker (60-528)

Connect interior speakers to the panel (see Figure 10 on page 19) using 18-gauge wire.

**Caution:** Connect only the large speaker to panel terminals 7 and 8 as shown. The smaller speaker cannot handle output to terminals 7 and 8. To avoid damaging the speaker, do not connect the smaller speaker to terminals 7 and 8.

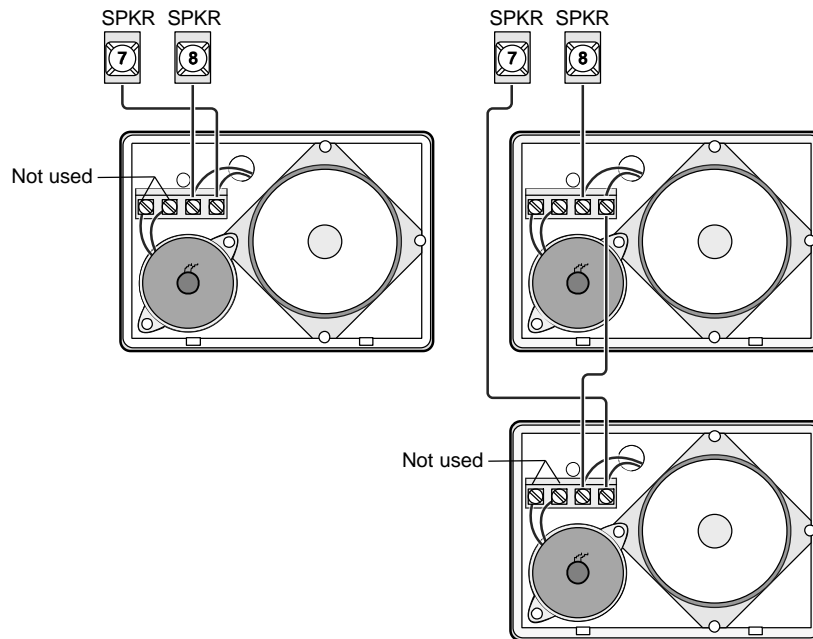

**Figure 10: Connecting hardwired interior speakers**

## Exterior/interior piezo sirens

Onboard output 1 (OUT 1—terminal 9) is a 9 to 14 VDC switched, programmable output that can handle a maximum of 1,000 mA current. The default setting (01614) activates the output 30 seconds after a police or fire alarm condition occurs. This allows you to connect a piezo siren without changing the output configuration number in programming. This output is typically used for exterior siren applications. Connect multiple piezo sirens in parallel. (For more information on output configuration numbers, see “Onboard options menu” on page 78.)

**Note:** For 24-hour backup, external power drain is limited to 90 mA (during normal standby condition), using a 4.5 or 5.0 Ah battery, or 190 mA continuous using a 7.0 Ah battery.

### Piezo dynamic exterior siren (13-950)

Connect the siren to panel as shown in Figure 11 on page 20.

**Figure 11: Connecting exterior sirens**

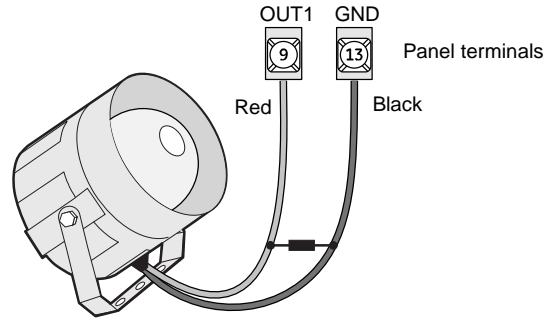

## Output 2

Onboard output 2 (OUT 2—terminal 10) is an open-collector (switched path-to-ground), programmable output that can handle a maximum of 300 mA current sink and up to 14 VDC. The default setting (01710) activates the output for status and alarm tones, allowing for a piezo siren connection without changing the output configuration number. This output is typically used for interior siren applications. (For more information on output configuration numbers, see “Onboard options menu” on page 78.)

## Hardwired interior siren (13-949)

This siren has two inputs, steady (#1) and warble (#2). Use the steady (#1) terminal for Concord 4 panels. The siren also includes a cover tamper switch that can be connected to a hardwired zone input on the panel, SnapCard or SuperBus 2000 hardwired input module. Connect the siren to the panel/zone input terminals as shown in Figure 12 below.

**Figure 12: Connecting an interior siren**

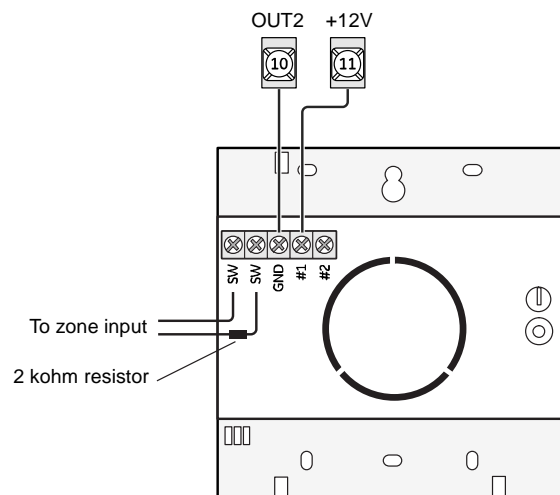

## Interrogator 200 audio verification module

A maximum of two audio verification modules (AVM) are allowed (partition 1 only). Connect the Interrogator 200 AVM to the panel terminals as shown in Figure 13 below. Use shielded cable to prevent crosstalk between the speaker and microphone.

**Figure 13: Connecting an Interrogator 200**

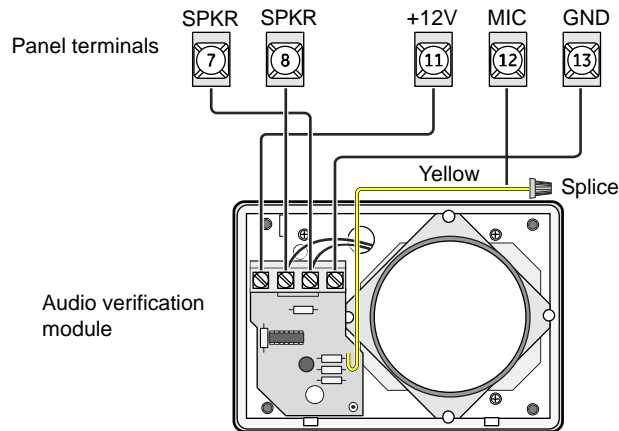

**Caution:** If a speaker is already connected to panel terminals 7 and 8, the Interrogator 200 speaker must be hooked up in series with that speaker to provide a 16-ohm load. Hooking up speakers in parallel to panel terminals 7 and 8 creates a 4-ohm load that can cause permanent damage to the panel.

## SuperBus 2000 touchpads

SuperBus 2000 touchpads may have wires or screw terminals. All use the same wiring scheme for power and bus connections. Connect touchpads as shown in Figure 14 below.

Figure 14: Connecting touchpads

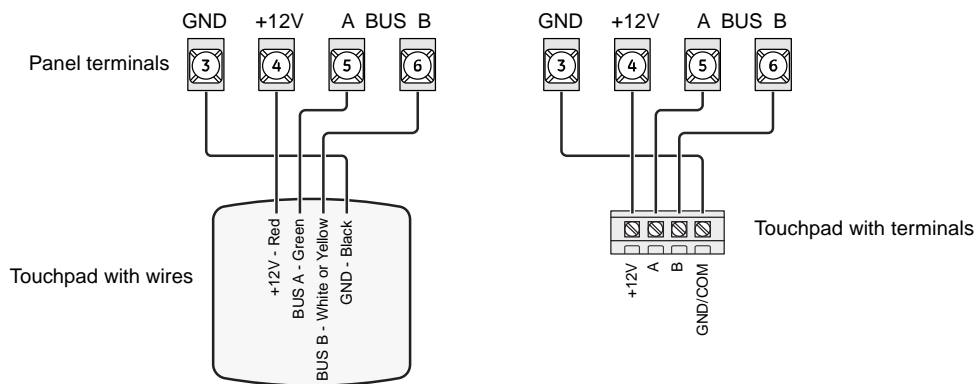

## SuperBus 2000 modules

You may install SuperBus 2000 modules inside the panel cabinet or away from the panel in the enclosure provided with the module.

### Mounting modules inside the panel enclosure

Use the following guidelines when mounting modules inside the panel enclosure (Figure 15 on page 23):

- Up to four of the SuperBus 2000 modules listed in Table 3 on page 3 can be mounted inside the cabinet.
- The 2-amp power supply and phone interface/voice module each use two mounting spaces when mounted inside the panel enclosure.
- The panel includes two support standoffs you install to secure module bookplates to the panel.

Even if you don't plan to mount modules inside the cabinet, install the support standoffs for future use and to avoid losing them.

The cabinet has built-in mounting clips on the top and sides that module backplates slide onto for mounting.

Figure 15: Installing SuperBus 2000 modules

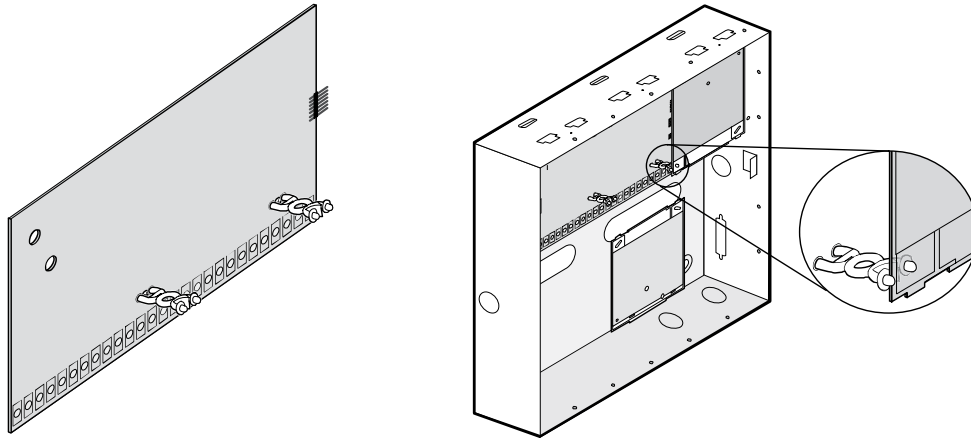

## SuperBus 2000 2-amp power supply (600-1019)

Refer to the power supply documentation for the mounting procedure. Connect the power supply to the panel terminals and devices to be powered as shown in Figure 16 below.

**Note:** Do not connect power (AC and battery) to the power supply until the panel is ready for power-up. For power supply AC and battery connections, refer to the power supply documentation.

Figure 16: Wiring the SuperBus 2-amp power supply to the panel

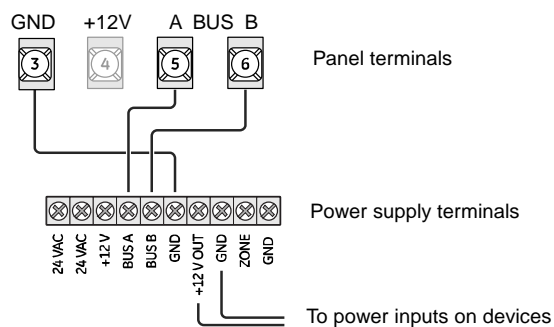

## SuperBus 2000 transceiver modules

The transceiver expands RF reception range when placed near sensors on the fringe of panel RF reception. Refer to the transceiver documentation for mounting information.

Connect the transceiver (up to four) to the panel as shown in Figure 17 on page 24.

**Figure 17: Wiring transceivers**

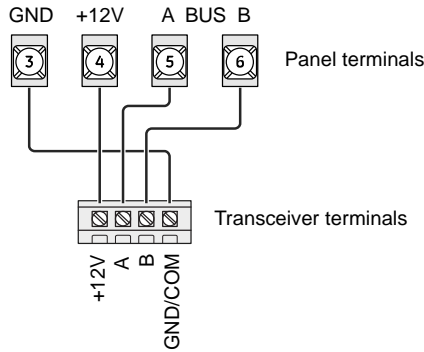

## SuperBus 2000 voice-only module

The module can be mounted inside or outside of the control panel cabinet. Refer to the documentation included with each module, for complete mounting instructions. For RJ-31X connections, see “RJ31X phone jack” on page 28.

The module requires panel power and bus connections, and speaker connection through panel terminals as shown in Figure 18 below.

**Figure 18: Wiring for the voice-only module**

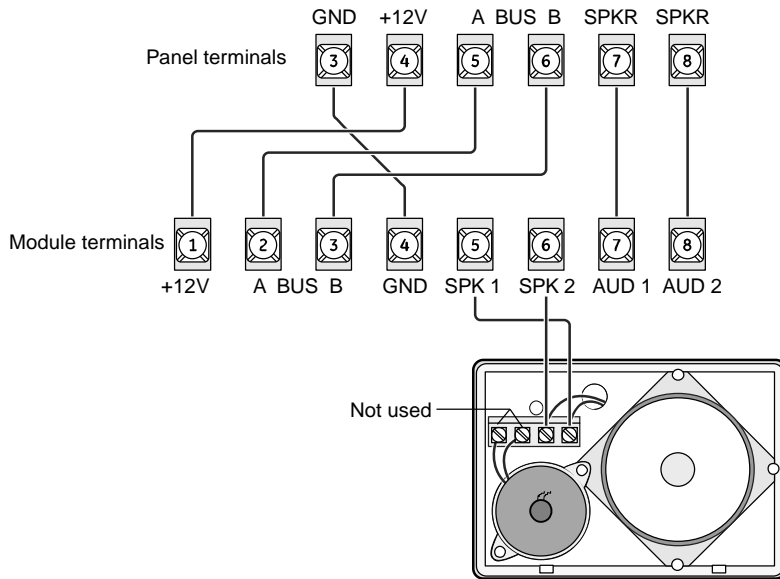

## SuperBus 2000 phone interface/voice module

The phone interface/voice module includes two backplates for mounting the module inside the control panel cabinet. You may also mount the module outside

of the cabinet using an optional plastic housing (part no. 60-800). Refer to the documentation that comes with each module, for complete mounting instructions.

The module requires panel power and bus connections, phone line connection through panel terminals and DB-8 cord (from an RJ-31X jack), and speaker connection through panel terminals. Connect the module to the panel power and bus terminals as shown in Figure 19 below.

For partition 1, connect the phone line to the module through the panel terminals and DB-8 cord (from an RJ-31X jack) as shown in Figure 19 below. For partitions 2 to 6 phone connections, see the documentation that comes with each module.

**Figure 19: Wiring the phone interface/voice module**

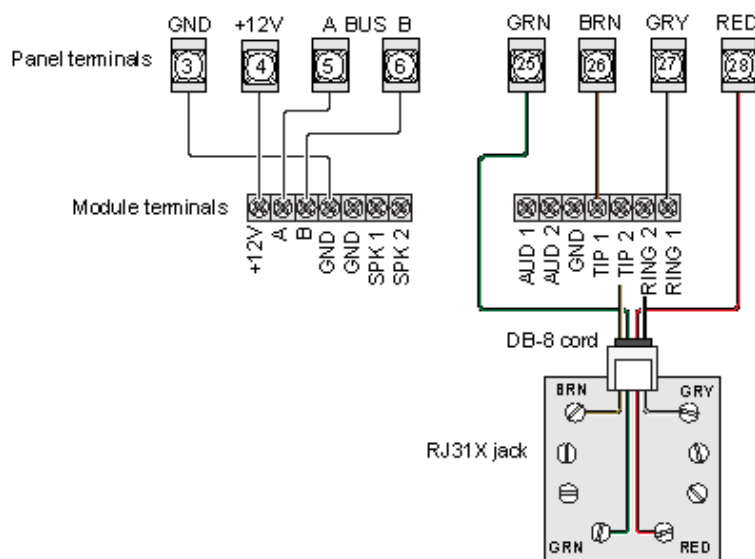

**Note:** To prevent status voice messages from being broadcast outside, do not connect exterior speakers to phone interface/voice module terminals 6 and 7.

### Wiring for status voice messages only

Connect an interior speaker to the phone interface/voice module terminals as shown in Figure 20 on page 26. When connected as shown, the speaker only produces status voice messages. In an alarm, the speaker announces voice status messages.

### Wiring for status and alarm messages

Make all of the connections shown in Figure 20 on page 26 only if the phone interface/voice module is being installed in partition 1 and alarm sounds are desired. In an alarm, the speaker alternates between alarm siren tones and voice status messages.

**Figure 20: Wiring for status and alarm (or status only) messages**

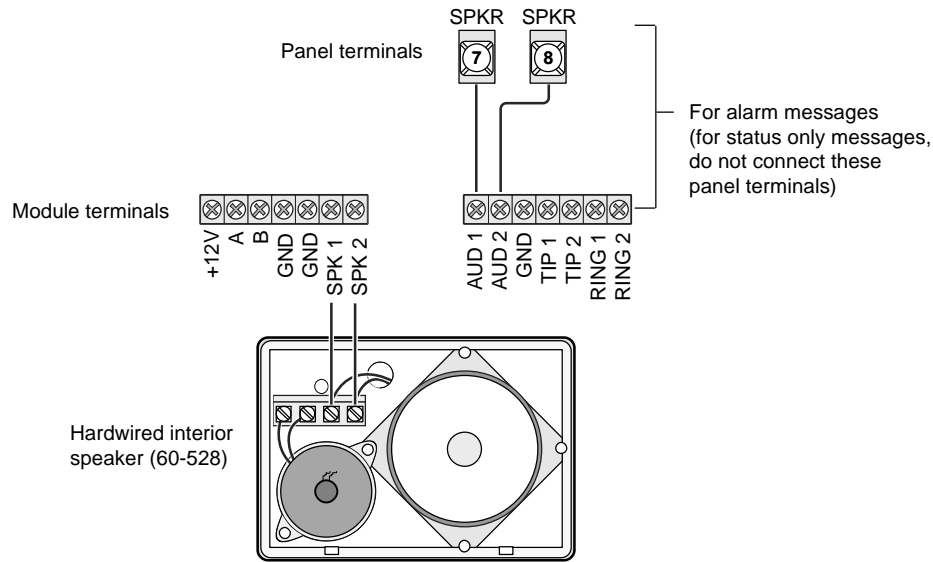

## SuperBus 2000 energy saver module

Connect the energy saver module to the panel and premises thermostat as shown in Figure 21 below. Refer to the energy saver module documentation for thermostat wiring details.

**Figure 21: Wiring the thermostat and energy saver module**

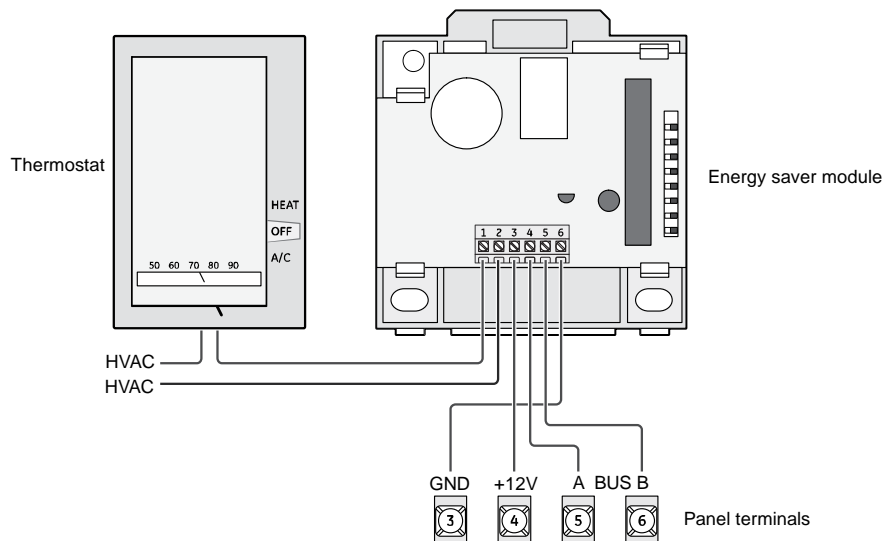



## SuperBus 2000 8Z input and 4-relay output modules

Connect the modules to the panel as shown in Figure 22 below. Connect all necessary input and output wiring using the module documentation.

Figure 22: Wiring input and output modules

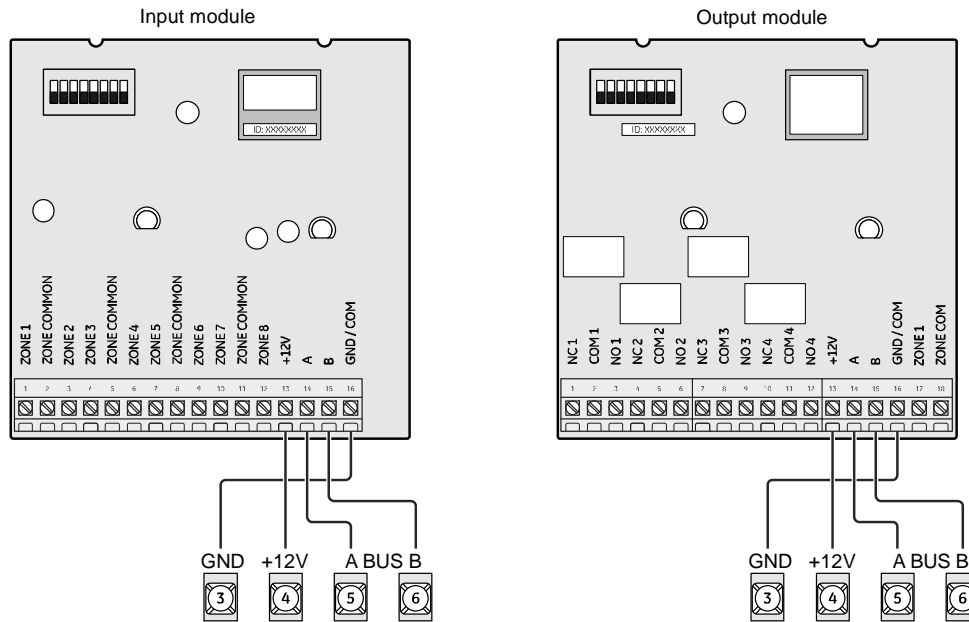

## SuperBus 2000 automation module

Connect the SuperBus 2000 automation module to the panel as shown in Figure 23 below.

Figure 23: Connecting an automation device

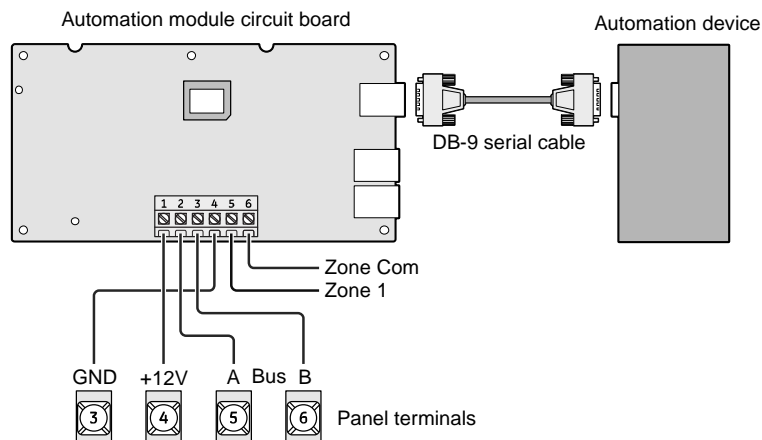

## SuperBus 2000 wireless cellular gateway

Connect the SuperBus 2000 wireless cellular gateway module to the SuperBus 2000 terminals as shown in Figure 24 below.

**Caution:** Since the SuperBus 2000 wireless cellular gateway module draws more than 1 amp, it must be powered by the SuperBus 2000 2-amp power supply and not the panel.

Figure 24: Connecting a wireless cellular gateway module

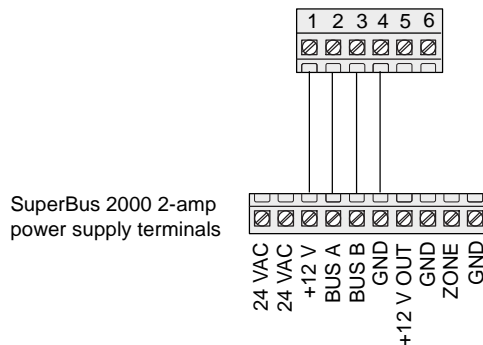

## Phones

The panel cannot be used on a digital or PBX phone line. These systems are designed for digital type devices only, operating anywhere from 5 VDC and up. The panel uses an analog modem and does not have a digital converter, adapter, or interface to operate through such systems.

**Note:** Some telephones are polarity-sensitive. Green and red wires may need to be reversed.

## RJ31X phone jack

Use the following guidelines when installing an RJ31X phone jack for system control by phone and central station monitoring:

- Locate the RJ31X jack (CA-38A in Canada) no further than 5 feet from the panel.
- The panel must be connected to a standard analog (loop-start) phone line, that provides 48 VDC (on-hook or idle).

- For full line seizure, install an RJ31X phone jack on the premises phone line so the panel is ahead of all phones and other devices on the line. This allows the panel to take control of the phone line when an alarm occurs, even if the phone is in use or off-hook.

**Note:** Connecting the panel to an analog line off the phone switch places the panel ahead of the phone system, preventing panel access from phones on the premises. However, the panel can still be accessed from offsite phones.

- If an analog line is not available, contact a telecommunication specialist and request an analog line off the phone switch (PBX mainframe) or a 1FB (standard business line).

#### **To connect a phone line to the panel using an RJ31X/CA-38A jack:**

1. Run a four-conductor cable from the TELCO protector block to the jack location.
2. Connect one end of the cable to the jack.
3. At the TELCO protector block, remove the premises phone lines from the block and splice them to the black and white (or yellow) wires of the 4-conductor cable.
4. Connect the green and red wires from the 4-conductor cable to the TIP (+) and RING (-) posts on the block.
5. Check the phones on the premises for a dial tone and the ability to dial out and make phone calls. If phones do not work correctly, check all wiring and correct where necessary.

### **Connecting the phone line to the panel with a DB-8 cord**

After installing the RJ31X jack, you are ready to connect the phone line to the panel. A DB-8 cord (not included) uses a plug at one end for connecting to the RJ31X module and flying leads on the other end for panel terminal connections.

#### **To connect the DB-8 cord to the panel terminals and RJ31X jack:**

1. Connect the green, brown, gray, and red flying leads from the DB-8 cord to panel terminals 25, 26, 27, and 28.
2. Insert the DB-8 cord's plug into the RJ31X.
3. Check the phones on the premises for a dial tone and the ability to dial out and make phone calls. If phones do not work correctly, check all wiring and correct where necessary.

**Figure 25: Wiring an RJ31X jack and DB-8 cord**

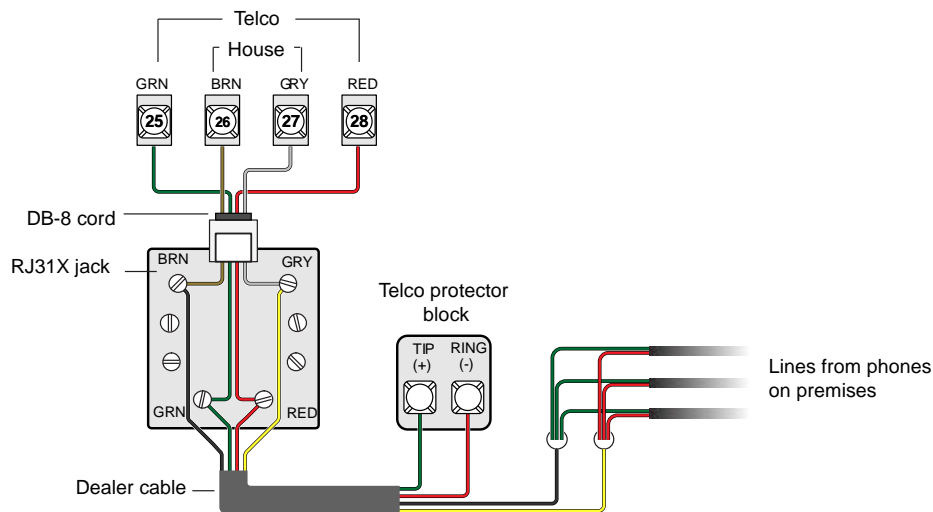

## Power

After connecting and wiring all devices to the panel, you are ready to apply AC and backup battery power to the panel.

**Caution:** Do not plug in the power transformer or connect the backup battery at this time. The panel must be powered up using the sequence of steps described in “Power up” on page 31.

### AC power transformer

The panel must be powered by a plug-in, step-down transformer that supplies 16.5 VAC, 40 VA (600-1023 or 600-1023-CN).

**Note:** Do not short the transformer terminals together. The transformer contains an internal fuse that permanently disables the output if the terminals are shorted.

For systems that include X10 lamp modules, the panel must be powered with the line carrier power transformer that supplies 16.5 VAC, 40 VA (600-1024 or 600-1024-CN). Connect the power transformer to the panel as shown in Figure 26 on page 31.

## Backup battery

Use the 60-681 (12 VDC, 4.5 or 5 Ah) or 60-680 (12 VDC, 7Ah) backup battery. The battery is automatically tested every 24 hours. Without AC power, the panel will shut down if the battery voltage falls below 10.2 VDC. Replace the battery when necessary with the same battery model.

**Note:** The backup battery leads must be routed along the side of the enclosure and secured with a cable tie.

**Figure 26: Connecting panel power transformer and backup battery**

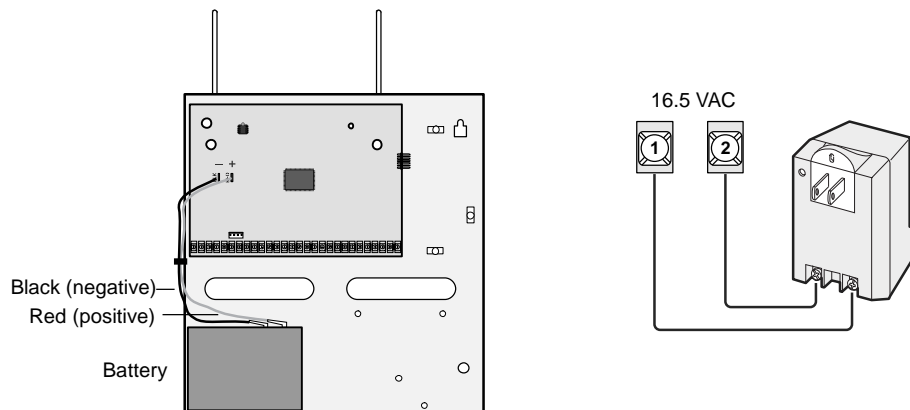

## Power up

### To power up the panel:

1. Connect the red and black backup battery leads (included with panel) to the lugs on the panel.
2. Connect the other ends of the backup battery leads to the battery terminals.
3. Plug the transformer into an outlet that is not controlled by a switch.
4. Alphanumeric touchpads display `*****`, then `SCANNING BUS DEVICES`, and finally a date and time display.

**Note:** If alphanumeric touchpads don't display anything, immediately unplug the transformer and disconnect the backup battery.

5. To permanently mount the transformer, unplug it and remove the existing screw securing the AC outlet cover

**WARNING:** Use extreme caution when securing the transformer to a metal outlet cover. You could receive a serious shock if a metal outlet cover drops

down onto the prongs of the plug while you are securing the transformer to the outlet box.

---

6. Hold the outlet cover in place and plug the transformer into the lower receptacle.
7. Use the screw supplied with the transformer to secure the transformer to the outlet cover.

# Chapter 3

# Programming

## Summary

This chapter provides instructions on how to program the Concord 4 and includes descriptions of the programming settings.

## Content

**Error! Bookmark not defined.**

## Overview

For onsite system programming, you must have an alphanumeric touchpad.

You must use an installer/dealer code (default = 4321) to enter program mode. You must disarm all partitions before you can place the system into program mode.

**Note:** If the system is powered up after the programming touchpad is connected or if a bus command scan is executed, the programming touchpad will be “learned” into the system and must later be manually deleted.

### To enter program mode:

1. Make sure you disarm the system in all partitions.
2. Press 8, 4321, 0, 0. The display shows `SYSTEM PROGRAMMING`.

### To enter program mode using a programming touchpad:

1. Connect the red, black, green, and white wires from the programming touchpad cable (60-791) to the power and bus wires/terminals on an alphanumeric touchpad, matching the +12V (red), Bus A (green), Bus B (white), and GND (black) on each.
2. Make sure the system is powered up and disarmed.
3. Connect the plug on the cable onto the panel programming touchpad header (see Figure 27 on page 35).
4. Press 8, 4321, 0, 2. The touchpad sounds one short beep. Press \* and verify that the display shows `SERVICE TOUCHPAD ACTIVE`.
5. Press 8, 4321, 0, 0 and the display shows `SYSTEM PROGRAMMING`.
6. After programming is complete, disconnect the touchpad from the panel header.

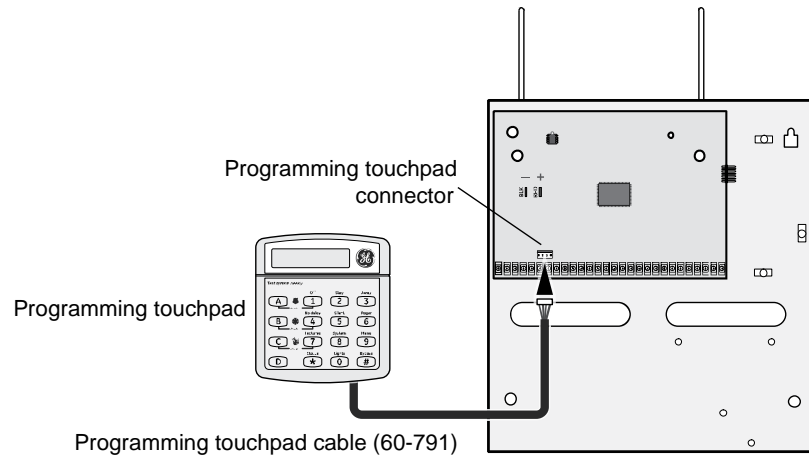

**Figure 27: Programming touchpad**

In program mode, touchpad buttons let you navigate to all installer programming menus for configuring the system. Table 8 below describes the touchpad button functions in program mode.

**Table 8: Touchpad programming functions**

Button	Programming function
#	Select menu item or data entry.
*	Deselect menu item or cancel data entry (if pressed before #).
A (▲) B (▼)	Scroll through available options at the current menu tier. Also, scroll through sensor text options during sensor text programming.
C	Enter pauses when programming phone numbers.
D	Delete certain programmed settings.
0 to 9	Enter numeric values wherever needed.
1 and 2	Select off (1) or on (2) wherever needed.
1 to 6	Press and hold to enter alphabetical characters A through F for account numbers
7 and 9	Press and hold to enter * (7) or # (9) for phone numbers.

## Quick programming mode

Use the quick programming mode to program basic system programming with a SuperBus 2000 fixed display touchpad, SuperBus 2000 FTP 1000 touchpad, or any SuperBus 2000 alphanumeric touchpad. The following menus are accessible:

- Account number (all partitions)
- CS phone 1
- CS phone 2
- CS phone 3
- Learn sensors—limited to selecting sensor number, sensor group, and partition assignment. An alphanumeric touchpad is required for programming sensor text in standard programming mode.

See Table 8 on page 35 for touchpad programming functions.

### To enter quick programming mode:

1. Make sure the system is disarmed in all partitions.
2. Press 8, *installer/dealer code*, 03. The display shows ACCOUNT NUMBER .
3. Cycle through the menus as shown in Table 9 below.

**Table 9: Quick programming menus**

Account number	Partition n (1 to 6)	Account number 00000
CS phone	CS phone 1	CS phone none
	CS phone 2	CS phone none
	CS phone 3	CS phone none
Learn sensors	Sensor partition n (1 to 6)	Sensor group 0 Trip sensor n (1 to 96)
End programming		

# Tier 1 programming menus

There are two basic tiers of programming menus as shown in Table 10 below.

**Table 10: Tier 1 and Tier 2 programming menus**

Tier 1	Tier 2
System programming	Security Phones Phone options Timers Light controls Touchpad options Reporting Siren options Sensors Audio verification Accessory modules Onboard options Macro keys
Demo kit	
Partition 1 copy	
Clear memory	
Exit programming	

This section guides you through tier 1 programming menu items as they appear in sequence. The exact order you follow depends on whether you're installing a new system or changing programming in an existing system.

---

<b>System programming</b>	Use this setting to access the tier 2 programming menus. (See “Tier 2 programming menus” on page 40.)
---------------------------	---

---

<b>Demo kit mode</b>	This setting determines whether you use your panel for a standard installation (off) or as a demo kit (on). When the demo kit option is on, only sensors learned into groups 01 and 03, duress code use, and phone test (8, <i>system master code</i> , 2) are reported. Turning on this feature and doing a memory clear changes the following settings:
----------------------	---

Default = Off

Partition 1 master code = 1000  
 Partition 2 master code = 2000  
 User code 00 = 1001 (partition 1 code – you may use to jump to partition 2)  
 User code 01 = 1002 (partition 1 code – you may use to bypass sensors)  
 User code 02 = 2001 (partition 2 code – you may use for remote or offsite access)  
 User code 03 = 2002 (partition 2 code – you may use to perform system tests)  
 User code 04 = 1122 (partition 1 code – you may use to jump to partition 2, for remote or offsite access, and system tests)  
 User code 05 = 2233 (partition 2 code – you may use to jump to partition 1, for remote or offsite access, bypassing sensors, and system tests)  
 Partition 1 house code = 255 (P)  
 Partition 2 house code = 254 (O)  
 Zone 1 (hardwired input 1) = Group 10, front door  
 Zone 2 (hardwired input 2) = Group 13, bedroom window  
 Zone 3 (hardwired input 3) = Group 17, living room motion sensor  
 Zone 4 (hardwired input 4) = Group 1, panic  
 Zone 5 (wireless keyfob, ID F00201) = Group 01, (no text)  
 Zone 6 (wireless DWS, ID A00206) = Group 13, kitchen window  
 Com failure = off, Demo kit = on  
 AVM code = 1212  
 Entry delay = 8 seconds  
 Exit delay = 8 seconds  
 Extended delay = 1 minute  
 Siren timeout = 2 minutes

To turn demo kit mode off or on:

1. With the display showing DEMO KIT MODE OFF/ON (current setting), press 1 (off) or 2 (on). The display flashes the entered setting.
2. Press #. The display shows DEMO KIT MODE OFF/ON (new setting).

---

---

<b>Partition 1 copy</b>	<p>After programming all settings pertaining to partition 1, you may make an exact copy to use for partitions 2 to 6. This helps reduce programming time when the system is set up for multiple partitions. If there are certain settings that are unique to partitions 2 to 6, simply advance to the appropriate menu and make the necessary changes.</p> <p>To copy partition 1:</p> <ol style="list-style-type: none"> <li>1. With the display showing <code>PARTITION 1 COPY</code>, press #, <i>installer code</i>, #. The display flashes.</li> <li>2. Press #. The display shows <code>DONE</code>.</li> </ol>
<b>Clear memory</b>	<p>Clearing memory deletes all existing programming information (except the dealer code).</p> <p><b>Note:</b> Clearing the memory erases onboard hardwired zone factory programming.</p> <p>To clear panel memory:</p> <ol style="list-style-type: none"> <li>1. With the system in program mode, press A or B until the display shows <code>CLEAR MEMORY</code>.</li> <li>2. Press #. The display shows <code>ENTER CODE TO CLEAR MEMORY</code>.</li> <li>3. Enter the four-digit installer or dealer code (if programmed) and press #.</li> </ol> <p>After about 5 seconds, the system restarts and the panel scans the bus to learn all bus devices. If the system doesn't respond as shown, repeat the process.</p>
<b>Exiting programming</b>	<p>After all installer/dealer programming is completed, exit programming mode.</p> <p>To exit programming mode:</p> <ol style="list-style-type: none"> <li>1. Press * until the display shows <code>SYSTEM PROGRAMMING</code>.</li> <li>2. Press A or B until the display shows <code>EXIT PROGRAMMING READY</code>.</li> <li>3. Press #. The touchpad displays the time and date.</li> </ol>

---

## Tier 2 programming menus

Table 10 below shows the tier 2 system programming menus. Where applicable, the setting name is followed by the (shortcut) and [default].

**Table 11: System programming menus**

Security	Global	Partition
	Downloader code (0000) [12345] Installer code (0001) [4321] Dealer code (0002) [****] Access code lock (0003) [On] Ptn security (0004) [On] Multi ptn arm (0005) [None] Keychain tp ptn (0006)	Account number (0010 to 0060) [00000] Quick arm (0011 to 0061) [Off] Quick exit (0012 to 0062) [Off] Exit extension (0013 to 0063) [On] Keyswitch sensor (0014 to 0064) [None] Keyswitch style (0015 to 0065) [Transition] Duress code (0016 to 0066) [****]
Phones	CS phone 1  Phone number (01000) [None] High lm rpts (01001) [On] Low lm rpts (01002) [On] Exception rpts (01003) [On] Open/close rpts (01004) [Off] Backup (01005) [On] Reporting format (01006) [CID] Cellular backup (01007) [On]	CS phone 2  Phone number (01010) [None] High lm rpts (01011) [Off] Low lm rpts (01012) [Off] Exception rpts (01013) [Off] Open/close rpts (01014) [Off] Backup (01015) [Off] Reporting format (01016) [CID] Cellular backup (01017) [Off]
	CS phone 3  Phone number (01020) [None] High lm rpts (01021) [Off] Low lm rpts (01022) [Off] Exception rpts (01023) [Off] Open/close rpts (01024) [Off] Backup (01025) [Off] Reporting format (01026) [CID] Cellular backup (01027) [Off]	Pager 1  Phone number (01030) [None] High lm rpts (01031) [On] Low lm rpts (01032) [Off] Exception rpts (01033) [Off] Open/close rpts (01034) [Off] Latchkey rpts (01035) [On] Streamlining (01036) [On] Ptn assignment (01037) [1]
	Pager 2  Phone number (01040) [None] High lm rpts (01041) [On] Low lm rpts (01042) [On] Exception rpts (01043) [Off] Open/close rpts (01044) [Off] Latchkey rpts (01045) [On] Streamlining (01046) [On] Ptn assignment (01047) [1]	Pager 3  Phone number (01050) [None] High lm rpts (01051) [On] Low lm rpts (01052) [On] Exception rpts (01053) [Off] Open/close rpts (01054) [Off] Latchkey rpts (01055) [On] Streamlining (01056) [On] Ptn assignment (01057) [1]

	Pager 4 Phone number (01060) [None] High IM rpts (01061) [On] Low IM rpts (01062) [On] Exception rpts (01063) [Off] Open/close rpts (01064) [Off] Latchkey rpts (01065) [On] Streamlining (01066) [On] Ptn assignment (01067) [1]	Pager 5 Phone number (01070) [None] High IM rpts (01071) [On] Low IM rpts (01072) [On] Exception rpts (01073) [Off] Open/close rpts (01074) [Off] Latchkey rpts (01075) [On] Streamlining (01076) [On] Ptn assignment (01077) [1]
	Downloader phone Phone number (01090) [None]	
Phone options	Global Phone test (02000) [On] Auto phone test (02001) [Off] Auto test reset (02002) [On] Comm failure (02003) [On] DTMF dialing (02004) [On] Dial abort delay (02006) [30 sec.] Cancel message (02007) [On] Pager delay (02008) [15 sec.] Call wait cancel (02009) [Off] Dial tone detect (02010) [On]	Partition Local phone ctrl (0210 to 0260) [On] Remote access (0211 to 0261) [On] Ring/hang/ring (0212 to 0262) [On] Line fail delay (0213 ptn 1 only) [None] Toll saver (0214 to 0264) [On] Phone panic (0215 to 0265) [Off] Phone ACC key (0216 to 0266) [#]
Timers	Global Supervisory time (0300) [Random] RF Tx timeout (0302) [12 hrs] Phone test freq. (0303) [7 days] Next phone test (0304) [7 days] Output trip time (0305) [4 seconds] Activity timeout (0306) [24 hours] Daylight savings (0307) [On]	Partition Entry delay (0310 to 0360) [30 seconds] Exit Delay (0311 to 0361) [60 seconds] Extended delay (0312 to 0362) [4 minutes] Siren timeout (0313 to 0363) [4 minutes] Sleep time (0314 to 0364) [22:00] No usage time (0315 to 0365) [None]
Light control	Partition Entry lights (0400 to 0450) [None] House code (0401 to 0451) [1B 2C 3D 4E 5F 6G]	
Touchpad options	Global Latchkey zones (0500) [None]	Partition Fire panic (0510 to 0560) [On] Auxiliary panic (0511 to 0561) [On] Police panic (0512 to 0562) [On] Keychain TP arm (0513 to 0563) [Off] Star is no delay (0514 to 0564) [Off]

Reporting	Global	Partition
	24-hour tamper (06000) [Off] Antenna tamper (06001) [Off] Buffer control (06002) [Off] Back in service (06003) [On] Bypass reports (06004) [Off] Low CPU battery (06005) [On] Battery restoral (06006) [Off] Buffer full report (06007) [Off] Zone restorals (06008) [Off] Two trip error (06009) [Off] TP panic rpt fmt (06010) [Off] AC failure (06011) [Off] Receiver failure (06012) [Off] RF low bat rpt (06013) [Weekly] RF supv rpt (06014) [Weekly] Swinger limit (06015) [1] Ground fault (06017) [On] Aux power fail (06016) [On]	Opening reports (06100 to 06600) [Off] Closing reports (06101 to 06601) [Off] No activity (06102 to 06602) [Off] Duress option (06103 to 06603) [Off] Force armed (06104 to 06604) [Off] Latchkey format (06105 to 06605) [Off] Freeze alarm (06106 to 06606) [Off] Freeze temp (06107 to 06607) [42] Alarm verify (06108 to 06608) [Off] System tamper (06109 to 06609) [Off] Report confirm (06111 to 06611) [Off]
Siren options	Global	Partition
	Immediate beeps (0700) [Off] Disable trbl beeps (0701) [Off] UL 98 options (0702) [Off] Global fire (0703) [Off] Silent panic (0704) [Off]	Siren verify (0710 partition 1 only) [Off]
Sensors	Learn sensors (080) Sensor partition 1 2 3 4 5 6 Sensor group [0] Trip sensor n	Sensor text (081) Text for sensor <i>n</i> Sensor <i>n</i> item 0
	Delete sensors (082) Delete sensor n Delete sensor n done	Edit sensors (083) Sn P1 Gnn NC/NO/TP/RF/HW Sensor partition n Sensor group n
Audio verification	Partition 1 Audio verify (09000) [Off] Audio mode (09001) [1] Fire shutdown (09002) [Off] Silent talkback (09001) [Off] Access timeout (09004) [90 seconds] Beep delay (09005) [2 seconds] Access code (09006) [****] VOX mic gain (09007) [14] VOX gain range (09008) [64] Manual mic gain (09009) [04] VOX RX gain (09010) [08]	



Accessory modules	Bus device Unit – ID (10000 to 10015) [Off] Change ID Device ID nnnnn Device partition Partition assign 1 2 3 4 5 6 Keypad options Status beeps [On] Key beeps [On] Energy options Freeze temp [42°F] Temperature 40 to 90 °F Temperature 40 to 90 °F Outputs Output in Partition assign 1 2 3 4 5 6 Configuration * * * * * Cellular options Cellular system [B]	
	<hr/> SnapCards Output programming                      Output text Output 1                                      Output 1 (10120) Partition assign (101100) [1]                      Output 1 item n Configuration (101101) [01400]                      Output 2 (10121) Output 2                                      Output 2 item n Partition assign (101110) [1]                      Output 3 (10122) Configuration (101111) [00410]                      Output 3 item n Output 3                                      Output 4 (10123) Partition assign (101120) [1]                      Output 4 item n Configuration (101121) [00903] Output 4 Partition assign (101130) [1] Configuration (101131) [01003]	
Onboard options	Inputs Smoke verify (1100) [Off] Two-wire smoke (1101) [Off]	
	<hr/> Output programming                      Output text Output 1                                      Output 1 (1120) Partition assign (11100) [1]                      Output 1 item n Configuration (11101) [01614]                      Output 2 (1121) Output 2                                      Output 2 item n Partition assign (11110) [1] Configuration (11111) [01710]	

The following sections guide you through the tier 2 system programming menu items as they appear in sequence:

- “Security menu” on page 45
- “Phones menu” on page 50
- “Phone options menu” on page 54
- “Timers menu” on page 57
- “Light control menu” on page 59
- “Touchpad options menu” on page 60
- “Reporting menu” on page 61
- “Siren options menu” on page 66
- “Sensors menu” on page 67
- “Audio verification menu” on page 71
- “Accessory modules menu” on page 73
- “Onboard options menu” on page 78
- “Macro keys” on page 81

Each tier 2 menu represents a group of settings related to the menu name. Some tier 2 menus break down into settings that affect the whole system (global) or a specific partition.

To advance to tier 2 menus from the tier 1 menu, scroll until the display shows `SYSTEM PROGRAMMING`, and then press `#`. The display shows `SECURITY` (the first tier 2 menu). You can then scroll through the tier 2 menus and submenus.

## Shortcut numbers

To go directly to some settings in tier 2, you can enter the shortcut number for that setting. Shortcut numbers in this section are provided after the setting name (where applicable). Shortcut numbers can be used from any setting location within tier 2.

# Security menu

## Security - global settings

<p><b>Downloader code</b> Shortcut: 0000 Default: 12345</p>	<p>Use the five-digit downloader code in conjunction with downloader programming. The downloader operator must have the panel account number and downloader code in order to perform any programming.</p> <p>You cannot delete the downloader code from the panel memory. To change the downloader code to its default setting, enter 12345. The downloader code resets to defaults during a memory clear only if the dealer code is not set or if the dealer code is used to initiate the memory clear.</p>
<p><b>Installer code</b> Shortcut: 0001 Default: 4321</p>	<p>The four-digit installer code is used for entering program mode and changing system settings. If you program a dealer code, only those settings not associated with phone numbers and the downloader code may be changed</p> <p>You may not delete the installer code or clear it from the panel memory. To change the installer code to its default setting, enter 4321.</p>
<p><b>Dealer code</b> Shortcut: 0002 Default: None</p>	<p>The four-digit dealer code is used to prevent unauthorized persons from changing the programmed central station phone numbers and downloader code. When this feature is enabled, central station phone numbers and the downloader code cannot be changed (unless you enter the program mode by using the dealer code). All other system settings are still accessible by entering the program mode with the installer code.</p> <p>The dealer code cannot be deleted by clearing panel memory. To delete a dealer code, with the display showing DEALER CODE nnnn (current code), press D. The display shows DEALER CODE ****.</p>
<p><b>Access code lock</b> Shortcut: 0003 Default: On</p>	<p>This feature determines whether the panel includes access codes when sending user information to the automation module. When this option is on, it means the access codes are not sent.</p>
<p><b>Partition security</b> Shortcut: 0004 Default: On</p>	<p>This feature controls whether an access code is necessary for partition jumping. When on, you must jump partitions with an access code by pressing 8, code, 6, PTN. When off, you may jump partitions without an access code by pressing 7, 4, PTN n (n = 1 to 6).</p> <p>Regardless of the setting, you may always use an access code to jump partitions.</p>

---

**Multipartition  
arm/disarm**

Shortcut: 0004

Default: Off. Partition to  
turn on

This feature controls which partitions (1 to 6) can be armed/disarmed simultaneously when using a touchpad and access code assigned to those partitions. When enabled, users can arm/disarm selected partitions using an authorized access code. When disabled, multiple partitions cannot be armed/disarmed simultaneously. For this feature:

- At least two partitions must be selected.
- Touchpads must be assigned to at least one of the selected partitions of this menu.
- Access codes must be assigned to all selected partitions of this menu. If the partition assignment for a specific access code does not match the partitions selected in this menu, only those partitions common to both menu settings can be armed/disarmed simultaneously with that code.
- A partition cannot be armed/disarmed if it is being controlled by another source at that time.
- All arming modifiers except Silent affect all partitions being armed. Only the arming partition can be armed silently.
- When arming multiple partitions, any conditions that prevent arming are identified on touchpad displays with the affected partition number flashing. The normal protest/auto force arm sequence follows, or pressing \* cancels the arming request.
- When disarming multiple partitions, any partitions in alarm have the affected partition number flashing on touchpad displays. Pressing # cancels all alarms in the selected partitions. Alarm memory information is then displayed for all canceled alarms.

To disable multipartition arm/disarm, with the display showing MULTI-PTN ARM/DISARM n n n n n n n, select all of the partitions by entering the appropriate partition number. The partition numbers disappear from the display. Press #.

---

**Keyfob PTN**

Shortcut: 0006

Default: On

This feature controls which partitions the selected keyfob can arm/disarm. When enabled, the selected keyfob can arm/disarm the partitions selected in this menu. When disabled, the selected keyfob cannot arm/disarm multiple partitions. For this feature:

- If no keyfobs are learned into panel memory, the menu displays `NOT AVAILABLE`. When keyfobs are learned into panel memory, two submenus appear. The first one lets you view keyfob assignments similar to that of viewing learned sensors. The second submenu lets you view and change the multipartition arming assignments for that keyfob.
- At least two partitions must be selected.
- Keyfobs can arm/disarm multiple partitions only for those partitions set up in the Multipartition arm/disarm menu.
- A partition cannot be armed/disarmed if it is being controlled by another source at that time.
- When arming multiple partitions from a keyfob, any conditions that prevent arming are identified on touchpad displays in the partition where that condition exists. Touchpad displays in all other partitions being armed display `PROTEST`. The normal protest/auto force arm sequence follows, or pressing \* on any touchpad in a partition being armed cancels the arming request. Pressing the Lock button again during a protest bypasses any open sensors in the affected partitions and arms those partitions.
- When disarming multiple partitions with a keyfob and alarms are active in one or more of the assigned partitions, protest beeps sound for 5 minutes in all partitions being disarmed; partitions in alarm where sirens have timed out sound protest beeps for 5 minutes; and partitions in alarm with active sirens continue sounding the alarm.

In any case where alarms are active the premises may not be safe to enter. The user has these options: leave and call for help from a safe location; if entering the premises anyway, go to a hardwired touchpad and check the system status to determine the alarm. Disarm and alarm memory is displayed for all assigned partitions; and press the keyfob Unlock button a second time (within the 5-minute protest period) to disarm all assigned partitions and cancel all alarms, then go to a hardwired touchpad and check alarm memory.

To enable keyfob PTN:

1. Learn all keyfobs into panel memory. (See “Sensors menu” on page 67.)
2. Enter this menu (display showing `KEYFOB TP PTN`), then press #. The display shows the lowest touchpad sensor number assignment such as: `S1 P1 G0 TP RF` where S1 is sensor 1, P1 is partition 1, G0 is sensor group 0, TP is touchpad and RF is wireless.
3. Press # to accept this keyfob or press A or B until the desired keyfob appears, then press #. The display shows `ARM PARTITION`.
4. Enter the desired partitions 1 to 6 (at least two). The display flashes the entered partitions.

---

5. Press # and the display stops flashing.

To disable keyfob PTN:

1. Enter this menu (display showing KEYCHAIN TP PTN), then press #. The display shows the lowest touchpad sensor number assignment such as: S1 P1 G0 TP RF where S1 is sensor 1, P1 is partition 1, G0 is sensor group 0, TP is touchpad and RF is wireless.

2. Press # to accept this keyfob or press A or B until the desired keyfob appears, then press #. The display shows ARM PARTITION.

3. Enter the partition numbers that are displayed (except for the partition you assigned the touchpad when it was learned). Each disappears from the display with the touchpad's original partition number left flashing.

4. Press # and the display stops flashing.

---

## Security - partition 1 to 6 settings

<p><b>Account number</b> Shortcut: 0010 to 0060 Default: 00000</p>	<p>The account number is used as panel (or customer) identification for the central monitoring station. The panel sends the account number every time it reports to the central station. Account numbers must be 1 to 10 characters long.</p> <p>Alpha characters A to F can be assigned to the account number by pressing and holding buttons 1 to 6 respectively, until the character appears.</p> <p>When using the CID reporting format, the letter A is reported as a 0.</p>
<p><b>Quick arm</b> Shortcut: 0011 to 0061 Default: Off</p>	<p>This feature allows system arming without using an access code. When quick arm is on, the system arming level can be increased from off to stay, from off to away, or from stay to away, without entering an access code. A valid access code is still required to decrease the arming level or disarm the system.</p>
<p><b>Quick exit</b> Shortcut: 0012 to 0062 Default: On</p>	<p>This feature determines whether or not users can open and close a standard entry/exit door without causing an alarm (while the system is armed). This feature also allows you to leave the armed premises without having to disarm and rearm the system. When this feature is on, pressing D on a touchpad (while the system is armed) starts a two-minute timer that allows one standard entry/exit door (sensor groups 10 and 19 only) to be activated once (opened, then closed). When this feature is off, you must disarm the system before any protected door is opened.</p>
<p><b>Exit extension</b> Shortcut: 0013 to 0063 Default: On</p>	<p>This feature determines whether you can reenter and exit again through an entry or exit delay door (without disarming and rearming the system). This helps prevent exit faults and false alarms by allowing you to reenter the premises for a forgotten item.</p> <p>When this feature is on, the panel restarts the exit delay timer if you reenter the premises through a standard delay door before the standard exit delay time expires. When this feature is off, the exit delay timer does not restart if you reenter the premises, forcing you to disarm the system to avoid setting off an accidental alarm.</p>
<p><b>Keyswitch sensor</b> Shortcut: 0014 to 0064 Default: None</p>	<p>This feature lets you arm and disarm the system using either a keyswitch wired to a hardwired zone input or a wireless door/window sensor (sensor 01 to 96).</p> <p><b>Note:</b> We recommend you program (learn) keyswitch sensors into group 28.</p> <p>For example, if sensor 1 is designated as the keyswitch sensor and the system is disarmed, then tripping sensor 1 could arm the system to Away. If the system is armed to Stay or Away, then tripping the sensor could disarm the system (depending on keyswitch style).</p> <p>The panel reports opening, closing, and force-armed reports (if turned on) to the central monitoring station.</p>

---

**Note:** A bypassed keyswitch sensor cannot arm or disarm the system. During an audible alarm, keyswitch sensors can disarm the system (which sends a cancel report to the central monitoring station), but cannot arm the system. The system can be armed only after the siren timeout expires. Keyswitch sensors test the same as any other sensor and do not arm or disarm the system during a sensor test.

To delete a keyswitch sensor, with the display showing `KEYSWITCH SENSOR nn` (current sensor number), press `D` to erase the keyswitch sensor attribute.

---

<p><b>Keyswitch style</b></p> <p>Shortcut: 0015 to 0065</p> <p>Default: Transition</p>	<p>This feature determines how the system behaves when armed/disarmed by a keyswitch sensor. The choices are as follows:</p> <p>Transition (press 1): If keyswitch style is set to transition and the keyswitch sensor is tripped (opened) when the system is disarmed, the panel will automatically arm to Away. If the sensor is tripped (opened) when the system is armed to Away or Stay, the panel will automatically disarm</p> <p>State (press 2): If keyswitch style is set to state, when the keyswitch sensor is tripped (opened) the panel arms to Away. If the sensor is restored (closed) the panel disarms.</p> <p>Opening, closing, and force arming reports (if turned on) are reported to the central station for both keyswitch styles.</p>
<p><b>Duress code</b></p> <p>Shortcut: 0016 to 0066</p> <p>Default: ****</p>	<p>The duress code is a unique 4-digit access code that allows users to operate the system and, at the same time, instructs the panel to send a silent alarm report to the central station.</p> <p>Do not use a duress code unless it is necessary. Using duress codes often results in false alarms due to code entry errors.</p> <p>To use this feature, the Duress option setting under the “Reporting menu” on page 61 must be turned on.</p>

---

## Phones menu

Use the Phones menu to set up central station reporting for the system. The Phones menu has the following submenus:

- Central station phones 1 to 3 (see “Phones - central station phone 1 to 3 settings” on page 51).
- Pager phones 1 to 5 (see “Phones - pager phone 1 to 5 settings” on page 52).
- Downloader phone (see “Phones - downloader phone settings” on page 54).



## Phones - central station phone 1 to 3 settings

<p><b>Phone number</b></p> <p>Shortcut: 01000, 01010, and 01020</p> <p>Default: None</p>	<p>Use this setting to program the central station receiver phone number. Phone numbers can be 1 to 24 digits long, including pauses or *and # characters.</p> <p>The phone menus are not accessible if a dealer code is programmed and the installer code is used to enter installer programming mode. To access these menus when a dealer code is programmed, you must enter installer programming mode using the dealer code. Call-waiting services should be disabled to prevent interrupting panel communication to the central monitoring station. To program a dialing prefix that disables call waiting, see the call wait cancel setting under the menu “Phone options - global settings” on page 54.</p> <p>To delete a central station phone number, with the display showing PHONE NUMBER (current number), press D. The display shows PHONE NUMBER _.</p>
<p><b>High level reports</b></p> <p>Shortcut: 01001, 01011, and 01021</p> <p>Default: On (1), Off (2 and 3)</p>	<p>When this setting is on, the following conditions report to the central station:</p> <ul style="list-style-type: none"> <li>• Fire, police, auxiliary, and duress alarms</li> <li>• No activity</li> <li>• Receiver failure (or jam)</li> <li>• Tamper conditions, including zone tampers and system tamper (40 incorrect key presses or touchpad supervisory)</li> <li>• Entering or exiting sensor test mode</li> <li>• Phone test</li> </ul>
<p><b>Low level reports</b></p> <p>Shortcut: 01002, 01012, and 01022</p> <p>Default: On (1), Off (2 and 3)</p>	<p>When this setting is on, the following nonalarm conditions report to the central station:</p> <ul style="list-style-type: none"> <li>• Force armed</li> <li>• Hardwired zone trouble (open or short)</li> <li>• Supervisory (wireless devices)</li> <li>• Low battery (wireless devices)</li> <li>• Phone test</li> <li>• Other nonalarm related conditions</li> </ul>
<p><b>Exception reports</b></p> <p>Shortcut: 01003, 01013, and 01023</p> <p>Default: Off</p>	<p>When this setting is on, the panel reports to the central station if the system is not armed or disarmed at the specified schedule times.</p>
<p><b>Open/close reports</b></p> <p>Shortcut: 01004, 01014, and 01024</p> <p>Default: Off</p>	<p>This setting determines whether opening and closing reports are sent to the central station. When turned on, the panel sends a closing report when the system is armed and an opening report when the system is disarmed.</p> <p>To use this feature, the opening reports and closing reports settings under the “Reporting menu” on page 61 must be turned on for that partition.</p>

<p><b>Backup</b></p> <p>Shortcut: 01005, 01015, and 01025</p> <p>Default: On (1), Off (2 and 3)</p>	<p>This setting determines whether the panel uses another programmed central station phone number for reporting if attempts with the first number are unsuccessful.</p> <p>When backup is off, the panel makes up to eight attempts to deliver a report with the programmed phone number. When backup is set to on, the panel makes up to 16 attempts to deliver the report, alternating between the programmed phone number and the backup phone number. Central station phone 1 is backed up by central station phone 2. Central station phones 2 and 3 are backed up by central station phone 1.</p>
<p><b>SIA/CID reporting</b></p> <p>Shortcut: 01006, 01016, and 01026</p> <p>Default: CID</p>	<p>This setting determines whether the panel uses the SIA (press 1) or CID (press 2) reporting format for central station communication.</p>
<p><b>Cellular backup</b></p> <p>Shortcut: 01007, 01017, and 01027</p> <p>Default: On (1), Off (2 and 3)</p>	<p>This setting determines whether the panel uses cellular communication for reporting if attempts using a landline are unsuccessful.</p>

## Phones - pager phone 1 to 5 settings

<p><b>Cellular backup</b></p> <p>Shortcut: 01030, 01040, 01050, 01060, and 01070</p> <p>Default: None</p>	<p>This feature programs a phone number that communicates to a pager. Phone numbers can be 1 to 24 digits long and include pauses, a sky link number, and 7-digit PIN code.</p> <p>Call-waiting services should be disabled to prevent interrupting panel communication to the pagers. To program a dialing prefix that disables call waiting, see the call wait cancel setting under the “Phone options - global settings” on page 54.</p> <p>To delete a pager phone number, with the display showing PHONE NUMBER (current number), press D. The display shows PHONE NUMBER _.</p>
<p><b>High level reports</b></p> <p>Shortcut: 01031, 01041, 01051, 01061, and 01071</p> <p>Default: On</p>	<p>This setting determines whether the following alarm conditions report to a pager:</p> <ul style="list-style-type: none"> <li>• Fire, police, auxiliary, and duress alarms</li> <li>• No activity</li> <li>• Receiver failure (or jam)</li> <li>• Tamper conditions, including zone tampers and system tamper (40 incorrect key presses or touchpad supervisory)</li> <li>• Entering or exiting sensor test mode</li> <li>• Phone test</li> </ul>

---

<p><b>Low level reports</b></p> <p>Shortcut: 01032, 01042, 01052, 01062, and 01072</p> <p>Default: Off</p>	<p>This setting determines whether the following nonalarm conditions report to a pager:</p> <ul style="list-style-type: none"> <li>• Force armed</li> <li>• Hardwired zone trouble (open or short)</li> <li>• Supervisory (wireless devices)</li> <li>• Low battery (wireless devices)</li> <li>• Phone test</li> <li>• Other nonalarm related conditions</li> </ul>
<hr/>	
<p><b>Exception reports</b></p> <p>Shortcut: 01033, 01043, 01053, 01063, and 01073</p> <p>Default: Off</p>	<p>This setting determines whether the panel reports to a pager if the system is not armed or disarmed at the specified schedule times, if open/close reports are turned on.</p>
<hr/>	
<p><b>Open/close reports</b></p> <p>Shortcut: 01034, 01044, 01054, 01064, and 01074</p> <p>Default: Off</p>	<p>This setting determines whether opening and closing reports are sent to a pager. When turned on, the panel sends a closing report when the system arms and an opening report when the system is disarms.</p> <p>To use this feature, the opening reports and closing reports settings under the “Reporting menu” on page 61 must be turned on for that partition.</p>
<hr/>	
<p><b>Latchkey reports</b></p> <p>Shortcut: 01035, 01045, 01055, 01065, and 01075</p> <p>Default: On</p>	<p>This setting determines whether the panel reports to a pager when the system arms or disarms, according to latchkey time scheduling.</p>
<hr/>	
<p><b>Streamlining</b></p> <p>Shortcut: 01036, 01046, 01056, 01066, and 01076</p> <p>Default: On</p>	<p>This setting determines whether the panel includes (off) or excludes (on) the account number when reporting to a pager.</p>
<hr/>	
<p><b>Partition assignment</b></p> <p>Shortcut: 01037, 01047, 01057, 01067, and 01077</p> <p>Default: 1</p>	<p>This setting determines the partition that reports to a pager. All partitions may be set to report to a single pager.</p>

---

## Phones - downloader phone settings

---

<b>Phone number</b> Shortcut: 01090 Default: None	<p>Use this setting to enter the phone number of an offsite computer that can be used to program the panel through the phone line. Phone numbers can be 1 to 24 digits long, including pauses or * and # characters.</p> <p>Call-waiting services should be disabled to prevent interrupting panel communication to the downloader. To program a dialing prefix that disables call waiting, see the call wait cancel setting under the “Phone options - global settings” below.</p> <p>To delete a downloader phone number, with the display showing PHONE NUMBER (current number), press D to erase the number. The display shows PHONE NUMBER_.</p>
---	---

---

## Phone options menu

A phone interface/voice module must be installed for the system to use these settings (except line fail delay).

### Phone options - global settings

---

<b>Phone test</b> Shortcut: 02000 Default: On	<p>This setting determines if you can test the communication from the panel to the central station or a pager by entering 8, <i>code</i>, 2 (#, 8, <i>code</i>, 2 from a touch tone phone).</p>
<b>Automatic phone test</b> Shortcut: 02001 Default: Off	<p>This setting determines if the panel sends a phone test automatically to the central station or a pager on a predetermined schedule. (See Phone test freq. and Next phone test under “Timers -global settings” on page 57).</p>
<b>Automatic test reset</b> Shortcut: 02002 Default: On	<p>This setting determines whether the automatic phone test interval is reset after any successful report to the central monitoring station. (See Phone test freq. and Next phone test under “Timers -global settings” on page 57). When this feature is on, the panel considers any successful report to the central monitoring station to be a successful phone test. Thus, any panel report resets the next phone test setting to the phone test frequency value. The panel only conducts an automatic phone test if no other reports have been made during the phone test frequency time. Phone test frequency must be set to 2 or higher for automatic test reset to work.</p> <p>When this feature is off, an automatic phone test is always conducted according to the schedule of the phone test frequency setting, even if the panel makes other reports to the central monitoring station during</p>

	that time.
<b>Communication failure</b> Shortcut: 02003 Default: On	This setting determines whether the panel activates trouble beeps to alert users on the premises that communication to the central station failed. Failure notification occurs after the third unsuccessful reporting attempt to the central station/pager.  Failure notification can occur immediately if inadequate phone line voltage is detected upon the initial dialing attempt.
<b>DTMF dialing</b> Shortcut: 02004 Default: On	This setting determines whether the panel uses DTMF tones (on) or pulse (off) for dialing programmed phone numbers.
<b>Dialer abort delay</b> Shortcut: 02006 Default: 30 seconds	This setting determines how much time the user has to abort a panel alarm report (15 to 45 seconds).
<b>Cancel message</b> Shortcut: 02007 Default: On	This setting determines whether the panel displays a cancel message after the user disarms the system to clear an alarm condition.
<b>Pager delay</b> Shortcut: 02008 Default: 15 seconds	This setting determines how long a report is delayed to a pager (0 to 30 seconds), after the panel dials the pager number.  The pager delay time should not be set below 5 seconds, unless necessary.
<b>Call wait cancel</b> Shortcut: 02009 Default: None	This feature sets up a dialing prefix to disable the call waiting feature before the panel makes its first dialing attempt to any programmed central monitoring station or downloader phone number. The prefix can be up to eight digits.  <b>Note:</b> We recommend that you program two pauses in any call wait cancel dialing prefix to ensure proper operation.  To delete the call wait cancel prefix, with the display showing <code>CALL WAIT CANCEL</code> (or current setting), press D.  <b>Caution:</b> Do not change this option from its default until verifying with the customer that he has call waiting with his phone service provider. Changing this option from its default without call waiting will prohibit the panel from calling the central station.
<b>Dial tone detect</b> Shortcut: 02010 Default: On	When this setting is on, the panel begins dialing as soon as it detects a dial tone. When this feature is off, the panel begins dialing a few seconds after seizing the phone line. There is no dial tone detect on the last dialing attempt.

## Phone options - partition 1 to 6 settings

<b>Local phone control</b> Shortcut: 0210 to 0260 Default: On	When this feature is on, the panel can be accessed from a phone on the premises.
<b>Remote access</b> Shortcut: 0211 to 0261 Default: On	When this setting is on, the panel can be accessed from an offsite phone.
<b>Ring/hang/ring</b> Shortcut: 0212 to 0262 Default: On	<p>This setting determines how the panel picks up (seizes) the phone line. Select On if an answering machine shares the phone line with the panel. Select Off if there is no answering machine sharing the phone line with the panel. The remote access setting must be turned on for this feature to work.</p> <p>When this feature is on, you must use do the following to call the panel, listen for one or two full rings and then hang up. Call the premises again within the next 10 to 40 seconds. The system answers after the first ring.</p> <p>When this feature is off, the system answers after 12 full rings.</p>
<b>Line fail delay</b> Shortcut: 0213 Default: None (partition 1 only)	<p>This setting determines the amount of time the partition 1 phone line voltage must be absent before the panel indicates a phone failure trouble condition (10 to 240 seconds). If a delay is <i>not</i> programmed (default), the panel will not monitor the phone line voltage. Line fail delay is not available for partitions 2 to 6 at this time.</p> <p>To delete the line fail delay time, with partition 1 selected, press A or B until the display shows <code>LINE FAIL DELAY nn SECS</code> (current setting). Press D to delete the current line fail delay time.</p>
<b>Toll saver</b> Shortcut: 0214 to 0264 Default: On	This setting determines whether the panel answers a phone call on the eighth ring (on) or twelfth ring (off) when a trouble or alarm condition exists.
<b>Phone panic</b> Shortcut: 0216 to 0266 Default: Off	This setting determines whether a police panic alarm can be activated from a touch-tone phone. When this feature is on, pressing #, ***** from a touch tone phone on the premises causes a panic alarm.
<b>Phone access key</b> Shortcut: 0216 to 0265 Default: #	<p>This setting determines which touch-tone phone button is used for system access and control. If the local phone control feature is enabled, the user can pick up the phone and press # (within 5 seconds) to access the security system. The panel seizes the phone line and waits for the user to enter system commands. Phone access can be changed from # (1) to * (2).</p> <p>Use the default setting (#) to avoid conflicts between the security system and other phone devices and services. Many phone devices and services require * to initiate their operation, so using * for this security feature could cause conflicts.</p>

# Timers menu

## Timers -global settings

<p><b>Supervisory time</b>            Shortcut: 0300            Default: set randomly between 01:00 and 4:00.</p>	<p>This setting determines what time of day the panel sends supervisory, low battery, or automatic phone test reports to the central station. Enter the 4-digit time value (HH:MM). For example, enter 0330 to set the supervisory time for 3:30 a.m.</p> <p>The panel clock must be set with the correct time for accurate supervisory time reporting. See “Time and date menu” on page 83.</p>
<p><b>RF Tx timeout</b>            Shortcut: 0302            Default: 12 hours</p>	<p>This setting determines how many hours (2 to 24) the panel has to receive at least one signal from a wireless sensor (learned into a supervised group). If the panel does not receive a signal from any supervised wireless sensor within the set time, the panel reports a supervisory condition to the central station.</p>
<p><b>Phone test frequency</b>            Shortcut: 0303            Default: 7 days</p>	<p>This setting determines how often (1 to 255 days) the panel conducts the automatic phone test (see “Phone options - global settings” on page 54).</p>
<p><b>Next phone test</b>            Shortcut: 0304            Default: 7 days</p>	<p>This setting is used by the automatic phone test feature under “Phone options - global settings” on page 54 to determine when the next automatic phone test should occur (1 to 255 days). This setting should be the same as, or less than, the phone test frequency setting.</p>
<p><b>Output trip time</b>            Shortcut: 0305            Default: 4 seconds</p>	<p>This setting determines how long outputs are activated when tripped (1 to 12 seconds), if they are configured for a momentary response.</p>
<p><b>Activity timeout</b>            Shortcut: 0306            Default: 24 hours</p>	<p>This setting determines when the system sends a no activity report (1 to 42 hours). If no user interaction or device activation occurs in that time, the panel sends a report to the central station.</p>
<p><b>Daylight saving</b>            Shortcut: 0307            Default: On</p>	<p>When this setting is on, the panel clock automatically adjusts for daylight saving time changes.</p>

## Timers - partition 1 to 6 settings

<p><b>Entry delay</b>          Shortcut: 0310 to 0360          Default: 30 seconds</p>	<p>This setting determines how much time you have to disarm the system (after entering the armed premises through a designated delay door) without causing an alarm (30 to 240 seconds).</p>
<p><b>Exit delay</b>          Shortcut: 0311 to 0361          Default: 60 seconds</p>	<p>This setting determines how much time you have (after arming the system) to leave the premises through a designated delay door without causing an alarm (45 to 184 seconds).</p>
<p><b>Extended delay</b>          Shortcut: 0312 to 0362          Default: 4 minutes</p>	<p>This setting determines how much time you have (after arming the system) to enter or exit the premises through a designated extended delay door (1 to 8 minutes).</p>
<p><b>Siren timeout</b>          Shortcut: 0313 to 0363          Default: 4 minutes</p>	<p>This setting determines how long sirens sound (1 to 30 minutes) if no one is present to disarm the system.</p>
<p><b>Sleep time</b>          Shortcut: 0314 to 0364          Default: 22:00 (10:00 p.m.)</p>	<p>This setting determines the start time and restart of a 10-hour window during which trouble beeps are suppressed (00:00 to 23:50 using 10 minute intervals). The initial occurrence of an event that causes trouble beeps within this window does not sound trouble beeps until the sleep time window expires. If trouble beeps from a previous event are due to be restarted during the sleep time window, they restart one hour prior to sleep time.</p> <p>To turn off sleep time, with the display showing SLEEP TIME hh:mm (current setting), press D.</p>
<p><b>No usage time</b>          Shortcut: 0315 to 0365          Default: None</p>	<p>This setting determines how many days (2 to 255) a partition can remain disarmed before the panel sends a no usage report to the central monitoring station and stores the event in the history buffer.</p> <p>When this feature is set:</p> <ul style="list-style-type: none"> <li>• This timer decreases by one at sleep time each day the selected partition remains disarmed.</li> <li>• If the timer gets to 0 at sleep time, the panel sends a no usage report to the central monitoring station and stores the event in the history buffer.</li> <li>• If the partition is armed before the timer reaches 0, the timer resets to the programmed setting.</li> </ul> <p>When this feature is not set (default), the panel does not send or log no usage reports.</p> <p>To turn off no usage time, with the display showing NO USAGE TIME (current setting), press D.</p>



## Light control menu

The Light control menu lets you set up light activation for a specific partition.

**Note:** For light control to work you must power the panel with a power line carrier transformer and X10 powerhouse lamp modules must be installed at desired lamps.

### Light control - partition 1 to 6 settings

---

<p><b>Entry lights</b></p> <p>Shortcut: 0400 to 0450</p> <p>Default: None</p>	<p>This setting determines which X10 controlled lights turn on during entry and exit delays.</p> <p>The X10 lamp modules set to 1 always turn on during the entry and exit delays. X10 lamp modules set to 2 always flash the arming level when arming the system. For example, lights flash two times when arming to stay (Level 2), and three times when arming to away (Level 3).</p> <p>To set the entry lights:</p> <ol style="list-style-type: none"> <li>1. With the desired partition selected, press #. The display shows ENTRY LIGHTS nnnnnnn (current setting).</li> <li>2. Enter all the desired light numbers (3 to 9) based on the unit dial setting on each X10 lamp module.</li> <li>3. The display flashes the entered settings. Press # and the display shows the new settings.</li> </ol> <p>To delete entry lights, enter any light number that appears on the display, then press #. The number disappears from the display.</p>
<p><b>House code</b></p> <p>Shortcut: 0401 to 0451</p> <p>Default: 01 B, 02 C, 03 D, 04 E, 05 F, and 06 G</p>	<p>This setting enables X10 controlled lights to work in a selected partition without interfering with the X10 controlled lights of the other partitions. After setting the panel house code for each partition, you must set the X10 controlled lights for that partition to the same house code. The letter that appears automatically after the house code number indicates the necessary house dial setting for X10 modules in that partition (1 to 255).</p>

---

# Touchpad options menu

## Touchpad options - global settings

---

<b>Latchkey zones</b>	This setting defines the range of keyfobs that will function as latchkey users (1 to 96). The value you enter in this section may be any valid zone number. When you enter a zone number, all zones <i>at or below</i> that zone number function as latchkey users. For example, if you enter 5, any keyfobs learned into zones 1 to 5 will be latchkey users and all others (6 to 96) will not.
Shortcut: 0500	
Default: None	
	To delete or disable latchkey zones, with the display showing LATCHKEY ZONES nnn (current setting), press D.

---

## Touchpad options - partition 1 to 6 settings

---

<b>Fire panic</b>	This setting determines whether touchpad fire panic buttons are enabled (on) or disabled (off).
Shortcut: 0510 to 0560	
Default: On	
<b>Auxiliary panic</b>	This setting determines whether touchpad auxiliary panic buttons are enabled (on) or disabled (off).
Shortcut: 0511 to 0561	
Default: On	
<b>Police panic</b>	This setting determines whether touchpad police panic buttons are enabled (on) or disabled (off).
Shortcut: 0512 to 0562	
Default: On	
<b>Keyfob (keychain TP) arm</b>	When this setting is on, pressing the Lock button on keyfob arms the system directly to away with no delay. When this setting is off, each key press increments the arming level (for example, from off to stay, from stay to away).
Shortcut: 0513 to 0563	
Default: Off	
<b>Star is no delay</b>	This setting determines whether the keyfob Star button controls an output (off) or the no delay feature (on).
Shortcut: 0514 to 0564	
Default: Off	

---

# Reporting menu

## Reporting - global settings

<p><b>24-hour tamper</b> Shortcut: 06000 Default: Off</p>	<p>When this setting is turned on, the panel sounds sirens and reports a tamper alarm (even when the system is disarmed), when nonfire wireless sensor tamper switches are activated.</p> <p>When this setting is turned off, the panel sounds sirens and reports a tamper alarm only when nonfire wireless sensor tamper switches are activated and those sensors are active for the current arming level. For nonfire sensors not active in the current arming level that have their tamper switch activated, trouble beeps sound and the panel sends a sensor tamper report to the central station if the system tamper feature is on for that partition.</p> <p>Tamper conditions for fire sensors (group 26) always cause trouble beeps to sound and report the tamper condition to the central station, regardless of this feature setting.</p>
<p><b>Antenna tamper</b> Shortcut: 06001 Default: Off</p>	<p>This setting determines whether the panel monitors for antenna tamper of onboard and all connected bus transceivers and receivers. When turned on, the panel sounds trouble beeps in all partitions and reports an antenna tamper condition. Touchpads in all partitions show a receiver tamper trouble condition. When turned off, the panel ignores antenna tampers.</p>
<p><b>Buffer control</b> Shortcut: 06002 Default: Off</p>	<p>When this setting is on, only arming level changes and time changes (system time and daylight saving time) are logged in the buffer (memory) of the panel. When this setting is off, all system events are logged in the buffer.</p>
<p><b>Back in service</b> Shortcut: 06003 Default: On</p>	<p>When this setting is on, the panel reports to the central station when AC and backup battery power are restored (after an extended power outage).</p>
<p><b>Bypass reports</b> Shortcut: 06004 Default: Off</p>	<p>When this setting is on, the panel reports to the central station whenever sensors or zones are bypassed.</p>
<p><b>Low CPU battery</b> Shortcut: 06005 Default: On</p>	<p>When this setting is on, the panel reports a low panel battery to the central station when the system battery test fails. If this setting and the Aux power fail feature are both on, the panel also monitors for and reports a low battery for the SuperBus 2000 2-amp power supply.</p>
<p><b>Battery restoral</b> Shortcut: 06006 Default: Off</p>	<p>If this setting is on, the panel reports to the central monitoring station when a wireless sensor or touchpad reports a battery replacement to the panel.</p>
<p><b>Buffer full report</b></p>	<p>When this setting is on, the panel sends an event buffer full report to the central monitoring station when the event buffer is nearing full.</p>

<p>Shortcut: 06007 Default: Off</p>	<p>When turned off, no report is sent.</p>
<p><b>Zone restorals</b> Shortcut: 06008 Default: Off</p>	<p>When this setting is on, the panel reports a restoral to the central monitoring station for wireless or hardwire zones in alarm before the alarm is canceled.</p> <p>Hardwired smoke detectors connected to panel or SnapCard hardwired zones do not send restorals.</p>
<p><b>Two-trip</b> Shortcut: 06009 Default: Off</p>	<p>This setting works with the Alarm verify setting (see Alarm verify in “Reporting - partition 1 to 6 settings” on page 64. If Alarm verify is on, the panel waits for a second sensor trip before sending an alarm.</p> <p>If two-trip is on and a second sensor trip does not occur within 4 minutes, the panel sends an error report to the central monitoring station.</p>
<p><b>Touchpad panic report format</b> Shortcut: 06010 Default: Off</p>	<p>This setting determines how the panel formats touchpad panic alarm reports to the central station. When this feature is turned on, touchpad panic alarms report using the following three-digit codes:</p> <ul style="list-style-type: none"> <li>• Auxiliary—597</li> <li>• Police—598</li> <li>• Fire—599</li> </ul> <p>When turned off, touchpad panic alarms report using a three-digit code from 500 to 515, with the last two digits identifying the touchpad device number.</p>
<p><b>AC failure</b> Shortcut: 06011 Default: Off</p>	<p>When this setting is on, the panel reports to the central station at a random time between 15 and 45 minutes after AC power to the panel is lost. Making the report random helps prevent systems in an area affected by a power outage from trying to report at the same time.</p> <p>If this feature and the auxiliary power failure feature are both on, the panel also monitors for and reports an AC failure for the SuperBus 2000 2-amp power supply.</p>
<p><b>Receiver failure</b> Shortcut: 06012 Default: Off</p>	<p>When this setting is on, the panel reports a receiver failure under the following conditions:</p> <ul style="list-style-type: none"> <li>• No wireless sensor signals have been received for two hours.</li> <li>• The receiver is being jammed with a constant signal.</li> </ul>

<p><b>Flow battery report</b> Shortcut: 06013 Default: Weekly</p>	<p>This setting determines whether the panel sends daily (1) or weekly (2) low battery reports to the central monitoring station when a wireless device is reporting a low battery condition to the panel.</p>
<p><b>RF low battery report</b> Shortcut: 06013 Default: Weekly</p>	<p>This setting determines whether the panel sends daily (1) or weekly (2) low battery reports to the central monitoring station when a wireless device is reporting a low battery condition to the panel.</p>
<p><b>RF supervisory report</b> Shortcut: 06014 Default: Weekly</p>	<p>This setting determines whether the panel sends daily (1) or weekly (2) reports to the central monitoring station when the panel detects a supervisory condition in a wireless device.</p>
<p><b>Swinger limit</b> Shortcut: 06015 Default: 1</p>	<p>This setting determines the maximum number of times (1 or 2) a sensor or zone can go into alarm (during a single arming period) before the panel automatically bypasses that sensor or zone. This feature only applies to sensors or zones in groups 00–20, 29, 34, 35, or 38.</p> <p>When set to 1, the panel automatically bypasses a sensor or zone after it causes an alarm. When set to 2, the panel waits until a sensor or zone has caused a second alarm (during the same arming period) before bypassing it. At any setting, the automatic bypass is logged into the event buffer.</p> <p>A bypassed sensor or zone will be cleared (automatically unbypassed) if the system receives no further activations from that sensor or zone over the next 48 to 50 hours.</p> <p>Changing the arming level also clears all automatically bypassed sensors and zones and resets the swinger limit count on all sensors and zones.</p>
<p><b>Auxiliary power failure</b> Shortcut: 06015 Default: On</p>	<p>When this setting is on, the panel sends a report to the central monitoring station if the 12 VDC power outputs on the panel and/or SuperBus 2000 2-amp power supply fail.</p> <p>If this feature is on and the AC failure and low CPU battery features are both on, the panel sends AC failure and low backup battery reports for the SuperBus 2000 2-amp power supply.</p>
<p><b>Ground fault</b> Shortcut: 06017 Default: On</p>	<p>When this setting is on, the panel will annunciate and send a report to the central monitoring station if it detects current flow between the panel's circuitry and the chassis. This indicates that a short to earth ground exists somewhere in the system.</p> <p>This feature must be on if hardwired smoke sensors are used in this system.</p>

## Reporting - partition 1 to 6 settings

<p><b>Opening reports</b>          Shortcut: 06100 to 06600          Default: Off</p>	<p>When this setting is on, the panel sends an opening report to the central station after disarming the system.</p> <p>To use this feature, the open/close reports settings under the “Phones menu” on page 50 must be turned on for the specific CS phone or pager number.</p>
<p><b>Closing reports</b>          Shortcut: 06101 to 06601          Default: Off</p>	<p>When this setting is on, the panel sends a closing report to the central station after arming the system.</p> <p>To use this feature, the open/close reports settings under the “Phones menu” on page 50 must be turned on for the specific CS phone or pager number.</p>
<p><b>No activity option</b>          Shortcut: 06102 to 06601          Default: Off</p>	<p>When this setting is on, the panel sends a no activity report to the central station when the activity timeout expires.</p>
<p><b>Duress option</b>          Shortcut: 06103 to 06603          Default: Off</p>	<p>When this setting is on, the system can be controlled using a programmed duress code (see “Security - partition 1 to 6 setting” on page 49) and will send a duress alarm to the monitoring station.</p> <p>Do not use a duress code unless it is necessary. Using duress codes often results in false alarms due to code entry errors. If a duress code is necessary, use it with the audio verification module to reduce false alarms and accidental dispatches. The audio verification module is listen only.</p>
<p><b>Force armed</b>          Shortcut: 06104 to 06604          Default: Off</p>	<p>When this setting is on, the panel reports to the central monitoring station when you “force arm” the system.</p> <p>Forced arming occurs if you press Bypass when arming the system with open sensors/zones protesting. Auto-forced arming occurs when you do not press Bypass when arming the system with open sensors/zones protesting, and then leave through an entry/exit door and the arming protest period expires. This causes the system to automatically bypass the open (protesting) sensors. Auto-forced arming always reports to the central monitoring station.</p>

<p><b>Latchkey format</b>          Shortcut: 06105 to 06605          Default: Off</p>	<p>This setting determines whether the selected partition is set up for basic (off) or advanced (on) latchkey opening report operation.</p> <ul style="list-style-type: none"> <li>• Basic: If the partition is armed by entering 2 (or 3), <i>code</i>, disarming using a designated latchkey user code or keyfob within an assigned time schedule sends a page. Arming the partition by entering 2 (or 3), <i>code</i>, 6 (latchkey) sends a page. If the partition is armed by entering 2 (or 3), <i>code</i>, 6 (latchkey), disarming using a designated latchkey user code or keyfob inside or outside of an assigned time schedule sends a page.</li> <li>• Advanced: Arming the partition by entering 2 (or 3), <i>code</i>, 6 (latchkey) within an assigned time schedule sends a page.</li> </ul> <p>Refer to the Concord 4 User Manual for complete latchkey setup and operation.</p>
<p><b>Freeze alarm</b>          Shortcut: 06106 to 06606          Default: Off</p>	<p>This setting determines whether the panel reports a freeze alarm to the central station or pager, when the selected partition's energy saver module detects a temperature that matches a predetermined setting.</p>
<p><b>Freeze temperature</b>          Shortcut: 06107 to 06607          Default: 42°F</p>	<p>This setting determines the temperature point the EnergySaver module detects a potential freeze (heating failure) condition. The adjustable range is from 40 to 90°F.</p> <p>This is the same menu found under "Accessory modules - bus device settings" on page 73.</p>
<p><b>Alarm verify</b>          Shortcut: 06108 to 06608          Default: Off</p>	<p>This setting determines whether the panel reports to the central monitoring station after a single sensor or zone trip (off) or waits for a second trip before reporting (on).</p> <p>This setting affects sensors/zones in groups 10 through 20. If Alarm verify is on, group 18 responds the same as group 17 (Table 24 on page 130).</p>
<p><b>System tamper</b>          Shortcut: 06109 to 06609          Default: Off</p>	<p>This setting determines how the panel handles possible tamper situations. When this feature is on, the panel reacts as follows:</p> <ul style="list-style-type: none"> <li>• Initiates an alarm when the system prompts for an access code (arming/disarming, etc.) and several wrong access codes are entered (40 consecutive invalid key presses).</li> <li>• Reports to the central station if a bus device stops communicating with the panel.</li> <li>• Reports to the central monitoring station if a tamper condition occurs on unarmed RF (wireless) devices.</li> </ul>
<p><b>Report confirm</b>          Shortcut: 06111 to 06611          Default: Off</p>	<p>When this setting is on, system status speakers announce, "Report is okay" followed by a single beep each time a successful report is made to the central monitoring station. When turned off, no status message or beep sounds.</p>

# Siren options menu

## Siren options - global settings

---

<b>Immediate beeps</b> Shortcut: 0700 Default: Off	This setting determines whether the panel activates trouble beeps as soon as a wireless device supervisory condition is detected (on), or if the panel waits 10 hours after the supervisory condition is detected to activate trouble beeps (off). (See “Timers -global settings” on page 57).
<b>Disable trouble beeps</b> Shortcut: 0701 Default: Off	When you turn on this setting, the panel does not initiate beeps to alert users of nonfire wireless device supervisory trouble and does not protest on arming if the condition exists.  If Immediate beeps is on, trouble beeps sound for supervisory trouble conditions regardless of this menu setting.
<b>UL 98 options</b> Shortcut: 0702 Default: Off	This setting determines whether the panel complies with UL 98 requirements (4-hour trouble beep restart, 4-hour backup battery test, 4-hour smoke (group 26) zone supervisory).
<b>Global fire</b> Shortcut: 0703 Default: Off	This setting determines whether sirens in all partitions sound (on) if any partition activates a fire alarm.
<b>Silent panic</b> Shortcut: 0704 Default: Off	This setting determines whether touchpad police panic alarms are audible (off) or silent (on).

---

## Siren options - partition 1 setting

---

<b>Siren verify</b> Shortcut: 0710 Default: Off	This setting determines whether the panel supervises the panel speaker terminals (7 and 8). When this feature is on, the panel indicates a trouble condition if no speaker is connected to panel speaker terminals.
---	---

---



## Sensors menu

---

### Learn sensors

Shortcut: 080

Default: None

The panel comes with factory programmed onboard hardwired zones. Install 2 kohm, end-of-line (EOL) resistors on all factory programmed hardwired zones. If you don't want to install EOL resistors, delete any unused zones from memory. Sensors must be placed in a partition or sensor group. To change the sensor group or partition assignment after adding a sensor or zone, use the Edit sensors menu.

To add (learn) sensors into panel memory:

1. With the display showing `SENSORS`, press `#` and the display shows `LEARN SENSORS`.
2. Press `#` and the display shows `SENSOR PTN 1`.
3. Press `#` to select partition 1 or press 2, 3, 4, 5, or 6, `#` to select the desired partition. The display should show `SENSOR GROUP 0`.
4. Enter the sensor group and press `#`. (See Table 24 on page 130 for a description of all sensor group characteristics.) The display shows `TRIP SENSOR nn`, where `nn` is the displayed (next available) sensor number.
5. To change the displayed sensor number, enter the desired sensor number and press `#`. The desired sensor number is displayed.
6. With the desired sensor number displayed, use the guidelines in Table 12 on page 70 to force the sensor or zone you are adding (learning) into the panel memory to send a signal to the panel.
7. To add another sensor to the same sensor group and partition, repeat the process.
8. To add sensors to another sensor group or partition, press `*` twice and repeat the process.

The factory default zone inputs and group number are:

Zone input 1 – Group 10 (entry/exit)

Zone input 2 – Group 17 (instant interior follower)

Zone input 3 to Zone input 8 – Group 13 (instant perimeter)

If the panel memory is cleared, all onboard zone factory programming will be erased.

---

---

<b>Sensor text</b> Shortcut: 081 Default: None	<p>Use the following guidelines to name zone and sensor locations:</p> <ul style="list-style-type: none"> <li>• Use the item numbers that appear in Table 25 on page 134 for characters and words listed there.</li> <li>• If a desired word does not appear in the table create it using the characters (custom text).</li> <li>• When using words from the table, spaces between them appear automatically. When using characters from the table to create words, you must reserve an item number for a 'space' after the word.</li> <li>• Each character or word uses one item number. For example, a word from the list counts as one item number.</li> <li>• Only 16 item numbers are allowed for each zone or sensor name, so plan before programming sensor text. You may need to abbreviate words to avoid running out of item numbers.</li> </ul> <p>To program sensor text:</p> <ol style="list-style-type: none"> <li>1. Press A or B until the display shows <code>SENSOR TEXT</code>.</li> <li>2. Press # and the display shows <code>TEXT FOR SN 01</code>.</li> <li>3. Press A or B until the display shows the desired sensor number (or enter the desired sensor number and press #).</li> <li>4. Press # and the display shows: <code>SN 1 ITEM 0 0 - _____</code>. Where ITEM 0 is the first character/word location and 0 is the character/word number.</li> <li>5. Enter the number of the character or word, or scroll through the numbers by pressing B (forward) or A (backward). If you make a mistake, enter the correct number or continue scrolling through choices.</li> <li>6. Press # to accept the displayed choice and the display shows: <code>SN 1 ITEM 1 0 -</code>.</li> <li>7. Repeat the process as needed to complete the zone or sensor name.</li> <li>8. Press * after entering the last character or word number. The display shows the complete text name. For example: <code>TEXT FOR SN 01 FRONT ENTRY DOOR</code>.</li> </ol>
<hr/> <b>Delete sensors</b> Shortcut: 082 Default: None	<p><b>Note:</b> Deleting sensors do not delete sensor text associated with the deleted sensor number. To delete sensor text, enter the sensor text setting and enter 000 (nulls) for each item number.</p> <p>To remove hardwired zone and wireless sensor numbers from panel memory:</p> <ol style="list-style-type: none"> <li>1. Press A or B until the display shows <code>DELETE SENSORS</code>.</li> <li>2. Press # and the display shows <code>DELETE SENSOR nn</code> (lowest zone/sensor number in panel memory).</li> <li>3. Press # to delete the displayed sensor or, enter the desired sensor number, then press #.</li> <li>4. Repeat the process until all desired sensors are deleted.</li> </ol>

---

---

**Edit sensors**

Shortcut: 083

Default: None

This menu lets you view and, if desired, change the group and partition assignment for each learned zone or sensor. For example, the display shows:

```
S01 P1 G13 NC HW BACK DOOR.
```

Where S01 is the zone/sensor number, P1 is partition 1, G13 is sensor group 13, NC is normally closed, HW is hardwired, and BACK DOOR is the programmed text name.

Other description codes include:

- RF (wireless sensor)
- TP (touchpad)
- NO (normally open)

To edit sensors:

1. Press A or B until the display shows `EDIT SENSORS`.
  2. Press # and the display shows the sensor or zone with the lowest number.
  3. Press A or B to scroll through all learned zones and sensors.
  4. When the desired zone or sensor is displayed, press #. The display shows `SENSOR PTN n` (current partition assignment).
  5. Enter the desired partition number, then press #. The display shows the new partition assignment.
  6. Press A or B and the display shows `SENSOR GROUP nn` (current group assignment).
  7. Enter the desired group number, then press #. The display shows the new group assignment.
-

Table 12 below describes how to trip different types of sensors to program (learn) them in the panel.

**Table 12: Tripping sensors**

Sensor	How to trip the sensor
Hardwired zones	Start with the zone in its “normal” state, and then trip the zone into its alarm state. A normally closed door, for example, should be closed when you begin the learn sensors process. To trip the zone, open the door.
Wireless sensors	Follow the instructions included with each sensor.
Wireless door/window sensors with external contacts	Place the external contact in the alarm condition, and then activate the sensor tamper switch.
Handheld wireless touchpads	Press the Bypass button.
Keyfobs	Press and hold the Lock and Unlock buttons together until the keyfob LED flashes.
ELM keyfobs	<p>Press and release the Unlock button twice quickly, then press and hold until the LED flashes three times.</p> <p>Press and release the Unlock button once quickly, then press and hold until the LED flashes two times.</p> <p>Press and hold the Unlock button until the LED flashes once.</p>

## Audio verification menu

The Audio verification menu lets you set up the audio verification module (AVM) operation in partition 1. If you want audio verification for partitions 2 to 6, you must install a standalone audio verification module and a four-relay output module (HOM) (60-770) output for that partition.

### Audio verification - partition 1 settings

<b>Audio verify</b> Shortcut: 09000 Default: Off	This setting determines whether the system can be accessed by phone for alarm verification.
<b>Audio mode audio verification</b> Shortcut: 09001 Default: 1	This setting determines how the audio verification module operates. Choose one of the following: <ul style="list-style-type: none"> <li>• Instant (1): Allows the central station operator instant access for an audio session by entering the AVM code or by pressing * (if an AVM access code is not programmed) upon completion of panel alarm report (see "Access timeout" below). The panel does not report any alarms during the AVM session except for fire alarms, even if the operator extends the session by pressing any valid key.</li> <li>• Callback (2): Allows the central station operator to place a call to the premises within 5 minutes of the alarm report (panel picks up after one ring). The operator must press * or enter the AVM access code within 20 seconds after ring. The panel does not report any alarms during the AVM session except for fire alarms, even if the operator extends the session by pressing any valid key.</li> <li>• Callback silent (3): Same as Callback, except premises phones do not ring.</li> </ul>
<b>Fire shutdown</b> Shortcut: 09002 Default: Off	This setting determines whether system sirens turn off during a fire alarm audio session.
<b>Silent talkback</b> Shortcut: 09003 Default: Off	This setting determines whether the central station operator can speak to persons on the premises (on) or only listen (off) during a silent or duress alarm audio session.
<b>Access timeout</b> Shortcut: 09004 Default: 90 seconds	If the audio mode is set to Instant, then this setting determines how much time (30 to 300 seconds, in 2-second increments) the central station operator has to enter the AVM access code after the panel is accessed for an audio session.
<b>Beep delay</b> Shortcut: 09005 Default: 2 seconds	This setting determines how long AVM access beeps are delayed (0 to 300 seconds, in 2-second intervals) at the beginning of a two-way audio session.

<p><b>Access code</b>                  Shortcut: 09006                  Default: **** or None</p>	<p>This setting determines the four-digit code required to access the audio verification module to start an audio session. If no code is programmed, pressing * starts an audio session.</p> <p>To delete an access code, with the display showing AUDIO VERIFY OFF/ON, press A or B until the display shows ACCESS CODE nnnn (current code). Press D to delete.</p>
<p><b>VOX microphone gain</b>                  Shortcut: 09007                  Default: 14</p>	<p>This setting determines the microphone sensitivity for triggering voice-activated switching (VOX). For the Interrogator 200, the default setting (14) is recommended.</p> <p>Room size, acoustics, and furnishings where the Interrogator 200 is located will influence the setting. Setting range is from 01 (low) to 64 (high).</p>
<p><b>VOX gain range</b>                  Shortcut: 09008                  Default: 64</p>	<p>This setting determines the gain range for voice-activated switching (VOX). Setting range is from 01 (low) to 64 (high). For best results, this setting should be higher than the VOX microphone gain.</p>
<p><b>Manual microphone gain</b></p>	<p>Not used.</p>
<p><b>VOX RX gain</b>                  Shortcut: 09010                  Default: 08</p>	<p>This setting determines the receiver (talkback) gain level for voice-activated switching (VOX). Setting range is 01 to 10. If the VOX is switching the speaker on when the central station operator is not talking, lower this setting and the VOX microphone gain setting. If the VOX is not switching the speaker on when the central station operator is talking, raise this setting and lower the VOX microphone gain setting.</p>

## Accessory modules menu

The Accessory modules menu gives you access to the following menus:

**Bus devices:** Use these settings to read bus device unit numbers, assign bus devices to a partition, and configure other features associated with a specific bus device. (Most bus device settings do not have shortcut numbers).

**SnapCards:** Use these settings to set the configuration number for each SnapCard output, assign SnapCard outputs to a partition, and name the SnapCard outputs.

### Accessory modules - bus device settings

---

#### Unit-ID

Shortcut: 10000 to 10015

Default: \*\*\*\* or None

This menu lets you identify all connected bus devices, view each unit number, view the device ID number, and configure other settings based on a specific device. This menu also lets you delete learned bus devices.

To help identify bus devices, the 8-digit device ID number is also located on a label on each SuperBus 2000 device.

To identify bus device unit and ID:

1. With the display showing `BUS DEVICES`, press #. The display shows the bus unit number and the 8-digit device ID number. For example: `UNIT - ID 0-02110185`. Where 0 is the unit number and 02110185 is the device ID number.
2. Press A or B to identify all other bus unit numbers (0 to 15) and device ID numbers.

To delete learned unit numbers:

1. With the display showing `BUS DEVICES`, press #. The display shows the bus device set to unit number 0.
  2. Press A or B until the bus device unit number you want to delete is displayed.
  3. Press D. The display changes the unit number to None.
-

---

**Device ID**

Default: None

This menu lets you change the bus device ID number when replacing a defective bus device.

To change a device ID:

1. With the display showing the desired bus device, press #, #. The display shows `DEVICE ID` (current ID).
2. Enter the ID of the new bus device. The display flashes the entered selection. Press # and the display shows the new setting.
3. Exit programming mode.
4. Remove AC and battery power from the panel.
5. Replace the defective bus device with a new one.
6. Apply AC and battery power to the panel.

---

**Partition assign**

This menu lets you assign bus devices to work in the desired partition.

**Note:** SuperBus 2000 8Z input modules, SuperBus 2000 4-relay output modules, and SuperBus 2000 RF receivers are not assigned to partitions.

To assign bus devices to partitions:

1. With the display showing the desired bus device, press #.
2. Press A or B until the display shows `DEVICE PTN` and then press #. The display shows `PARTITION ASSIGN n`.
3. Press 1 to 6 to select the desired partition. The display flashes the entered selection. Press # and the display shows the new setting.



**Output programming** Use these settings to program the output points of any installed SuperBus 2000 hardwire output module. The installer programs a HOM output point into the Concord security panel by entering three kinds of information.

- Partition: The system partition (1 to 6).
- Trigger: The event that activates the output point. Trigger events can be partition alarms, trouble conditions, open sensors, etc.
- Response: How the output responds to a trigger event.

Only the onboard and SnapCard outputs can be configured for user control.

To program each of the HOM output point configurations into the security panel:

1. With the display showing the desired bus device, press #.
2. Press A or B until the display shows `OUTPUTS`.
3. Press #. The display shows `OUTPUT 1`.
4. Press A or B to select an output, then press #. The display shows `PARTITION ASSIGN 1`.
5. Press 1 to 6 to select the desired partition assignment for this relay. The display flashes the entered setting. Press # and the display shows the new setting.
6. Press A or B. The display shows `CONFIGURATION ttrr` (current setting). The point configuration number is `ttrr`, where `t` is the trigger number and `r` is the response number.
7. Enter the desired five-digit configuration number for this relay. The display flashes the entered setting. Press # and the display shows the new setting.
8. Press # and repeat the process until all outputs are programmed.

---

**Status beeps** This setting determines whether the selected touchpad sounds status beeps. Each touchpad can be set individually. This feature is usually turned off for a touchpad that is located in or near bedrooms, to avoid disturbing sleeping persons.  
Default: On

---

**Key beeps** This setting determines whether or not selected touchpads beep when their buttons are pressed. This feature is usually turned off for a touchpad that is located in or near bedrooms, to avoid disturbing sleeping persons.  
Default: On

---

<b>Freeze temperatures</b> Default: 42°F	<p>This setting determines the temperature point (40 to 90°F) that the energy saver module detects a potential freeze (heating failure) condition.</p> <p>This is the same menu found under Reporting – partition 1 to 6 settings. The setting is used by both the SuperBus 2000 energy saver module and dialog RF thermostat. Individual freeze temperature settings for each device are not allowed.</p>
<b>Temperatures</b> Default: None	<p>This setting lets you adjust the energy saver module (ESM) room temperature setting (40 to 90°F) to match the premises thermostat.</p> <p>To ensure accuracy, wait at least 15 minutes before setting the ESM temperature to allow the ESM to warm or cool to actual room temperature.</p>
<b>Cellular system</b> Default: B	<p>This setting determines the cellular transmission system, A (press 2) or B (press 1) used for cellular communication. This information is provided by the cellular provider based on installation zip code.</p>

## Accessory modules - SnapCard settings

<b>Output programming</b>	<p>This setting lets you assign a partition and a five-digit configuration number for each SnapCard relay output. This number determines both which system event activates the output and the duration or time the output is activated.</p> <p>To program the settings:</p> <ol style="list-style-type: none"><li>1. Assign the partition (1 to 6).</li><li>2. Assign the configuration number (combination of a trigger number and a response number).<ul style="list-style-type: none"><li>• Trigger: The event that activates the output point. Trigger events can be partition alarms, trouble conditions, open sensors, etc.</li><li>• Response: How the output responds when trigger event occurs.</li></ul></li></ol> <p>To assign configuration numbers to SnapCard relay outputs:</p> <ol style="list-style-type: none"><li>1. With the display showing <code>SNAPCARDS</code>, press #. Then press A or B until the display shows <code>OUTPUT PROGRAMMING</code>.</li><li>2. Press # again and the display shows <code>OUTPUT 1</code>.</li><li>3. Press A or B to select the desired output (1 to 4), then press #.</li><li>4. With the display showing <code>PARTITION ASSIGN 1</code>, press 1 to 6 to select the desired partition. Press # to confirm the partition.</li><li>5. Press A or B until the display shows <code>CONFIGURATION t t t r r</code> (current setting).</li><li>6. Enter the desired five-digit configuration number for this relay. Press # to confirm the setting.</li><li>7. Press # and repeat the process until all outputs are programmed.</li></ol>
---------------------------	---

---

**Output text**Shortcut: 10120 to  
10123

Default: None

Entering text for an output allows the user to control it directly or by schedule. Use the following guidelines to name SnapCard outputs:

- Use the item numbers that appear in Table 25 on page 134 for characters and words listed there.
- If you want an output for user output control, you must use the output text feature to name the output. If no output text is programmed, the user will not have access to the output.
- When using words from Table 25 on page 134, spaces between them appear automatically. When using characters from the table to create words, you must reserve an item number for a *space* after the word.
- Each character or word uses one item number. For example, a word from the list counts as one item number.
- Only 16 item numbers are allowed for each output name, so plan before programming output text. You may need to abbreviate words to avoid running out of item numbers.

To program output text:

1. With the display showing `SNAPCARDS`, press #, then A or B until the display shows `OUTPUT TEXT`.
  2. Press # and the display shows `OUTPUT 1`.
  3. Press A or B until the desired output number is displayed.
  4. Press # and the display shows `OUTPUT N ITEM 0 0 -` where `ITEM 0` is the first character/word location and `0` is the character/word number.
  5. Enter the number of the desired character or word, or scroll through the numbers by pressing B (forward) or A (backward). If you make a mistake, enter the correct number or continue scrolling through choices.
  6. Press # to accept the displayed choice and the display shows `OUTPUT N ITEM 1 0 -`.
  7. Repeat the process as needed to complete the output name.
  8. Press \* after entering the last character or word number. The display shows the complete text name. For example: `OUTPUT 1 GARAGE DOOR`.
-

## Onboard options menu

The Onboard options menu includes input, output programming, and output text settings.

### Onboard options - inputs settings

---

<b>Smoke verify</b> Shortcut: 1100 Default: Off	<p>This setting control the number of sensor group 26 (fire) zone trips needed to report a fire alarm.</p> <p>When turned off, hardwire and wireless smoke alarms are reported immediately.</p> <p>When turned on:</p> <ul style="list-style-type: none"><li>• Hardwire smoke sensors. Onboard or SnapCard zones learned into group 26 must be in alarm for at least 3 seconds or tripped twice within 5 minutes before activating system sirens and reporting to a central station (or pager).</li><li>• Wireless smoke sensors. The first trip of a group 26 RF sensor will cause a local fire alarm. The second trip of any group 26 zone within the siren timeout will cause that fire alarm to be reported to the central station.</li></ul> <p><b>Note:</b> RF smoke detectors repeat the alarm transmission every 60 seconds as long as they are detecting smoke. This repeated transmission will serve as the second zone trip, causing the alarm to be reported.</p> <p><b>Note:</b> For California State Fire Marshall Listed installations, this feature must be off.</p>
<b>Two-wire smoke</b> Shortcut: 1101 Default: Off	<p>This setting determines how onboard hardwired zone 8 is configured. When this setting is on, zone 8 will be configured for two-wire smoke detectors. When off, it will be configured for a normal hardwire input.</p>

---

## Onboard options - output programming settings

---

<p><b>Output 1, 2</b></p> <p>Shortcuts:          11100 (output 1ptn)          11101 (configuration);          11110 (output 2 ptn),          11111 (configuration)</p> <p>Default:          Ptn 1, 01614 (output 1)          Ptn 1, 01710 (output 2)</p>	<p>This setting assigns the partition and the five-digit configuration number for the two onboard outputs. The configuration number determines:</p> <ul style="list-style-type: none"> <li>• Which system event activates the selected output.</li> <li>• The duration or time the output is activated.</li> </ul> <p>The first three digits represent the trigger number of an event (such as triggering an alarm, opening a sensor, or arming the system). The last two digits represent how the output responds, For example, momentary switching, maintained (or latched) switching, or switching for a preset time.</p> <p><b>Note:</b> If you want to configure an output for user output control you must use the output text feature to name the output. If no output text is programmed, user output control will not function for that output.</p> <p>Use the system event trigger and response numbers listed in Table 31 on page 143.</p> <p>To set up onboard output 1 and 2 partition and configuration assignments:</p> <ol style="list-style-type: none"> <li>1. With the display showing ONBOARD OPTIONS , press #, B. The display shows OUTPUT PROGRAMMING.</li> <li>2. Press # and the display shows OUTPUT 1. Press B to select output 2.</li> <li>3. Press # and the display shows PARTITION ASSIGN n (current setting).</li> <li>4. Press 1 to 6 to assign the output to the desired partition, then press #. The display shows PARTITION ASSIGN (new setting).</li> <li>5. Press B and the display shows CONFIGURATION tttrr (current setting).</li> <li>6. Enter the configuration number. The display flashes the entered number. Press # and the display shows the new setting.</li> <li>7. Press # and repeat the process until all outputs are programmed.</li> </ol>
--	---

---

## Onboard options - output text settings

---

### Output text

Shortcut: 1120 to 1121

Default: None

Entering text for an output allows you to control it directly or by schedule. Use the following guidelines to name onboard outputs:

- Use the item numbers listed in Table 25 on page 134 for characters and words.
- If you want to configure an output for user output control you must use the output text feature to name the output. If no output text is programmed, output control will not function for that output.
- If a desired word does not appear in Table 25 on page 134, create it using the characters (custom text).
- When using words from the table, spaces between them appear automatically. When using characters from the table to create words, you must reserve an item number for a space after the word.
- Each character or word uses up one item number. For example, a word from the list counts as one item number.
- Only 16 item numbers are allowed for each output name, so plan before programming output text. You may need to abbreviate words to avoid running out of item numbers.

To program output text:

1. With the display showing ONBOARD OPTIONS, press # then press B twice and the display shows OUTPUT TEXT.
  2. Press # and the display shows OUTPUT 1.
  3. Press # and the display shows: OUTPUT 1 ITEM 0 0 -. Where ITEM 0 is the first character or word location and 0 is the character or word number.
  4. Enter the number of the character or word, or scroll through the numbers by pressing B (forward) or A (backward). If you make a mistake, enter the correct number or continue scrolling through choices.
  5. Press # to accept the displayed choice and the display shows OUTPUT 1 ITEM 1 0 -.
  6. Repeat the process as needed to complete the output name.
  7. Press \* after entering the last character or word number. The display shows the complete text name. For example, OUTPUT 1 GARAGE DOOR.
-

## Macro keys menu

The macro keys menu lets you set up single-button system commands with the ATP2100 and ATP2600 touchpads.

### Macro keys - partition 1 to 6 settings

---

#### Macro keys

Default:

Chime 71 (macro 1),  
Stay 2 (macro 2),  
Quick Exit D (macro 3),  
Away 3 (macro key 4)

This menu lets you program the Chime, Stay, Exit, and Away macro keys on ATP2100 and ATP2600 touchpads. Macro keys let you perform a system command with one button, eliminating manual entry of the command. For example, the Stay key can be programmed so that it automatically arms the system to Level 2 with no delay just by pressing it once.

- Each partition can accept up to four macros.
- All touchpads in a partition use the same set of macros.
- Macro keys can execute a system command up to 14 key presses in length. Use keys 0 to 9, #, \*, and A to F to program macros.
- Panic keys, long key presses (press and hold), and macro keys themselves cannot be used in a macro.
- When programming a macro to enter user programming, you must enter two delays (F key) after the access code - and before any shortcut number. For example, the macro key sequence for entering the set time menu would be 9CODEFF020.
- When using an ATP2100 or ATP2600 to jump to another partition, pressing the macro buttons on the jumped touchpad will execute macro commands based on the macros programmed in the jumped partition.

**Note:** We recommend that you do not program macros that disarm the system.

To program/change a macro key:

1. With the display showing **MACRO KEYS**, press #. The display shows **PARTITION 1**.
  2. Press A or B to select the desired partition (1 to 6), then press #. The display shows **MACRO KEY 1** (current setting).
  3. Press A or B to select the desired macro key you want to program (1 to 4).
  4. To change this macro, press the associated macro key. The current setting disappears and is replaced with a flashing cursor.
  5. Enter the desired system command. The display flashes the entry. If you make a mistake, press the macro key twice to clear the entry and start over.
  6. Press the macro key again to accept the entered command. The display stops flashing.
-

## User programming mode

The user programming mode allows you to view system version information and program system settings. You can enter user programming from an alphanumeric or fixed display touchpad by using the system or partition master code. The default system master code is 1234. To enter user programming mode, press 9, *code*. The display shows `TIME AND DATE`. The default settings are shown in brackets in the table where applicable.

**Table 13: User programming menus**

Time and date	Time	
	Date	
User codes	Regular user	User 00 Direct bypassing [Off] Remote access [Off] System test [Off] Latchkey report [Off] Partition assign [1]
	Partition master	Partition master code [None]
	System master	System master code [1234]
Options	Downloading [On]	
	Touchpad brightness [2]	
	Volume [4]	
	Voice chime [On]	
	Chime on close [Off]	
Set up schedules	Schedule 00 to 15	Start time [00:00] Stop time [00:00] Monday [Off] Tuesday [Off] Wednesday [Off] Thursday [Off] Friday [Off] Saturday [Off] Sunday [Off]
	Latchkey opening	Schedule 00 to 15 [Off]
	Latchkey closing	Schedule 00 to 15 [Off]
	Exception opening	Schedule 00 to 15 [Off]
	Exception closing	Schedule 00 to 15 [Off]
	Lights 1 to 9	Schedule 00 to 15 [Off]
	Output 1 to 6	Schedule 00 to 15 [Off]
Arming	Schedule 00 to 15 [Off]	



	Away	Schedule 00 to 15 [Off]
Energy saver	Low setpoint 45 to 89° [50]	
	High setpoint 48 to 90° [90]	
Exit programming		
System version	Factory code	
	System number	
	System level	
	SW version	

## Time and date menu

The panel uses a global clock and calendar for time and date. This menu lets you set this clock and calendar. Alphanumeric touchpads display the panel time and date whenever the system is disarmed.

**Note:** Setting the time and date is important for accurate tracking of system events stored in the event buffer.

<b>Time</b>	This setting lets you adjust the panel clock to the correct time. The panel uses a 24-hour clock (HH:MM). For example, to set the time to 4:17 p.m., enter 1617.
Shortcut: 020	
Default: 00:00	
<b>Date</b>	This setting lets you adjust the panel calendar to the correct month, day, and year. Enter the correct month (01 to 12), day (01 to 31), and year (00 to 99). For example, enter 090107 for September 1, 2007.
Shortcut: 021	
Default: 01/01/00	

## User codes menu

The user codes menu lets you program/change regular user access codes, partition master codes, and the system master code. You can enter up to 230 separate user codes, allowing up to 230 different users access to the security system. You can also specify whether a specific user is able to perform specific actions, like bypassing sensors or testing the system.

---

### User nnn

Shortcut: 030nnn0,  
where nnn is user  
number 000 to 229

Default: None

User codes provide basic arming and disarming functions. The system allows up to 230 user codes (user numbers 000 to 229). User numbers that show \*\*\*\* indicate no code is currently programmed for that user number.

To program regular user codes:

1. With the display showing USER CODES, press # and the display shows REGULAR USER CODES .
2. Press # and the display shows USER nnn (first available user number).
3. Press A or B to select the desired user number, then press #. The display shows USER nnn - nnnn.
4. With the user number displayed, enter a four-digit user code. The display flashes the entered code. Press # and the display shows USER nnn - nnnn (new code).

To delete regular user codes:

1. With the display showing USER CODES, press # and the display shows REGULAR USER CODES .
  2. Press # and the display shows USER nnn - nnnn (first available user number).
  3. Press A or B to select the user number/user code you want to delete (if it is not already displayed), then press #. The display shows USER nnn - nnnn.
  4. Enter the system or partition master code. The display flashes the entered code. Press # and the display shows USER nnn -- \*\*\*\* (no code).
-

---

**Direct bypassing**

Shortcut: 030nnn1,  
where nnn is user  
number 00 to 229

Default: Off

This setting determines whether a specific user code provides access to the bypass sensors feature. Set this feature to on for all users who need to be able to bypass sensors.

To turn the direct bypassing setting off or on:

1. With the display showing `USER CODES`, press # and the display shows `REGULAR USER CODES`.
  2. Press # and the display shows `USER nnn` (first available user number).
  3. Press A or B to select the desired user number, then press #. The display shows `USER nnn - nnnn`.
  4. Press A or B until the display shows `DIRECT BYPASSING OFF/ON` (current setting).
  5. Press 1 (off) or 2 (on). The display flashes the entered setting. Press # and the display shows the new setting.
- 

**Remote access**

Shortcut: 030nnn2,  
where nnn is user  
number 000 to 229

Default: Off

This setting determines whether the user can access the panel from a remote phone (a phone located off the premises).

To turn the remote access setting off or on:

1. With the display showing `USER CODES`, press # and the display shows `REGULAR USER CODES`.
  2. Press # and the display shows `USER nn` (first available user number).
  3. Press A or B to select the user number, then press #. The display shows `USER nnn - nnnn`.
  4. Press B until the display shows `REMOTE ACCESS ON/OFF` (current setting).
  5. Press 1 (off) or 2 (on). The display flashes the entered setting. Press # and the display shows the new setting.
- 

**System tests**

Shortcut: 030nnn3,  
where nnn is user  
number 000 to 229

Default: Off

This setting determines whether a specific user code provides access to the phone and sensor tests. Set this feature to on for all users who need to be able to conduct phone and sensor tests.

To turn the system tests setting off or on:

1. With the display showing `USER CODES`, press # and the display shows `REGULAR USER CODES`.
  2. Press # and the display shows `USER nn` (first available user number).
  3. Press A or B to select the user number, then press #. The display shows `USER nnn - nnnn`.
  4. Press A or B until the display shows `SYSTEM TESTS OFF/ON` (current setting).
  5. Press 1 (off) or 2 (on). The display flashes the entered setting. Press # and the display shows the new setting.
-

---

**Latchkey report**

Shortcut: 030nnn4,  
where nnn is user  
number 000 to 229

Default:

On (for 000 to 005),  
Off (for 006 to 229)

This setting determines whether the user code causes a latchkey report to be sent to a pager when the code is used to change arming levels.

To assign the latchkey report attribute to user codes:

1. With the display showing `USER CODES`, press # and the display shows `REGULAR USER CODES`.
2. Press # and the display shows `USER nn` (first available user number).
3. Press A or B to select the user number, then press #. The display shows `USER nnn - nnnn`.
4. Press A or B until the display shows `LATCHKEY OFF/ON` (current setting).
5. Press 1 (off) or 2 (on). The display flashes the entered setting. Press # and the display shows the new setting.

---

**Partition assign**

Shortcut: 030nnn5  
where nnn = user  
number 000 to 229

Default: Ptn 1

This setting determines which partitions a user code can access. A code can be assigned to all partitions if desired, making it usable at any touchpad in any partition and able to jump to any selected partition.

To assign partitions to a user code:

1. With the display showing `USER CODES`, press # and the display shows `REGULAR USER CODES`.
2. Press # and the display shows `USER nn` (first available user number).
3. Press A or B to select the user number, then press #. The display shows `USER nnn - nnnn`.
4. Press A or B until the display shows `PARTITION ASSIGN` (current setting).
5. Enter the desired partitions (1 to 6). The display flashes the entered numbers. Press # and the numbers stop flashing.

---

**Partition master**

Shortcut: 0310 to 0315

Default: None

The partition master code provides access to all system operations and user programming for a single partition. You must be in the partition of the partition master code you wish to change.

To change the partition master code:

1. With the display showing `USER CODES`, press # then A or B until the display shows `PARTITION MASTER CODE`.
  2. Press # and the display shows `PARTITION nnnn` (current code).
  3. Enter a new four-digit code. The display flashes the entered code. Press # and the display shows the new code.
-

---

<b>System master</b>	The system master code provides access to all system operations and user programming. In the partition where the indicating power device is located, only the system master code may be enabled to disarm that partition.
Shortcut: 0320	
Default: 1234	
	To change the system master code:
	1. With the display showing <code>USER CODES</code> , press # then A or B until the display shows <code>SYSTEM MASTER CODE</code> .
	2. Press # and the display shows <code>SYSTEM MASTER nnnn</code> (current code).
	3. Enter a new four-digit code. The display flashes the entered code. Press # and display shows the new code.

---

## Options menu

The Options menu lets you set up the system for downloading and silent arming. You can also adjust alphanumeric touchpad display brightness from this menu.

---

<b>Downloading</b>	When this setting is on, the panel can communicate with Enterprise Downloader software for programming the system from offsite.
Shortcut: 041	
Default: On	For this feature to work, the panel must be connected to a phone line and be programmed with remote access on, with a Downloader phone number, and with a Downloader code.
<b>Touchpad brightness</b>	This setting lets the user lighten or darken the background on touchpad displays. Each touchpad can be set to compensate for lighting conditions in the touchpad location. Enter a setting from 0 (darkest background) to 3 (brightest background).
Shortcut: 043	
Default: 2	
<b>Volume</b>	This setting determines the volume level of status sounds from speakers connected to the phone interface/voice module or voice only module (VOM).
Shortcut: 044	
Default: 4	This menu setting appears only if a phone interface/voice module or a VOM is connected to the panel. Enter a setting from 0 (off) to 7 (loudest).
<b>Voice chime</b>	This setting determines whether speakers connected to the phone interface/voice module or voice-only module announce perimeter sensor/zone numbers that are tripped when the chime feature is on. This menu appears only if a phone interface/voice module or a VOM is connected to the panel.
Shortcut: 045	
Default: On	
<b>Chime on close</b>	When this setting is on, the panel sounds a single chime when a perimeter door or window is closed.
Shortcut: 046	
Default: Off	

---

## Set up schedules menu

The set up schedules menu lets you set up timeframes for light control, output control, automatic arming, latchkey times, and exception opening/closing reports. The system (all partitions) allows you to set up to 16 schedules (00 to 15) that are shared by all partitions.

Setting up schedules consists of setting a start and stop time for each schedule, then selecting which days of the week the schedule will be active. You can also set up a rollover schedule, which starts on one day and ends on another day. This saves programming time and leaves more schedules available (in case they are needed later).

For example, to set up a schedule to rollover from Tuesday evening to Wednesday morning, set a schedule start time for 2200 (10:00 p.m.) and a stop time for 0500 (5:00 a.m.). Set the schedule to turn on Tuesday. Because the stop time is set for morning, the system automatically carries the schedule over to the next day.

If you use the same start and stop times described above and set the schedule to turn on Monday through Friday, then one schedule will cover the entire week.

---

**Set up schedules**

Shortcut: 05XXY,  
where XX is schedule  
00 to 15 and Y is start  
(0)/stop (1) Monday to  
Sunday (2 to 8)

Default: 00:00

This menu lets you set up start/stop times for each day of the week. Schedules used by one partition cannot be viewed or changed from a different partition.

If you are programming schedules for your customer, be sure to record the settings in the *Concord 4 User Manual*.

To set up a time schedule:

1. Press A or B until the display shows SET UP SCHEDULES.
  2. Press # and the display shows SCHEDULE 00. If you want a different schedule number, press A or B until the schedule number appears.
  3. Press # and the display shows START TIME hh:mm (current setting).
  4. Enter the starting time (00:00 to 23:59). The display flashes the entered time. Press # and the display shows START TIME hh:mm (new setting).
  5. Press B and the display shows STOP TIME hh:mm (current setting).
  6. Enter the desired stop time (00:00 to 23:59). The display flashes the entered time. Press # and the display shows STOP TIME hh:mm (new setting).
  7. Press B and the display shows MONDAY OFF/ON (current setting). To select a different day, continue pressing B until the desired day appears.
  8. Press 1 (off) or 2 (on). The display flashes the entered selection. Press # and the display shows the new setting for the selected day.
  9. Repeat the process until all desired settings for each day are set.
-

## Attach schedules to events menu

This section describes how to link the system events to time schedules.

---

### Latchkey reports

Shortcut:

060nn (opening),  
061nn (closing), where  
nn is schedule number

Default: Off

This setting lets you attach the latchkey opening report feature and the latchkey closing report feature to time schedules.

To attach a schedule to latchkey opening or latchkey closing:

1. Press A or B until the display shows ATTACH SCHEDULES TO EVENTS.
2. Press # then A or B until the display shows LATCHKEY OPENING OR LATCHKEY CLOSING.
3. Press # and the display shows SCHEDULE 00 OFF/ON (current setting). If you want a different schedule, press A or B until the desired schedule appears.
4. Press 1 (off) or 2 (on). The display flashes the entered selection. Press # and the display shows the new setting for the selected schedule.

---

### Exception reports

Shortcut:

062nn (opening),  
063nn (closing), where  
nn is schedule number

Default: Off

This setting lets you attach the exception opening report feature and the exception closing report feature to time schedules.

To attach a schedule to exception opening or exception closing:

1. Press A or B until the display shows ATTACH SCHEDULES TO EVENTS.
  2. Press # then A or B until the display shows EXCEPTION OPENING OR EXCEPTION CLOSING.
  3. Press # and the display shows SCHEDULE 00 OFF/ON (current setting). If you want a different schedule, press A or B until the schedule appears.
  4. Press 1 (off) or 2 (on). The display flashes the entered selection. Press # and the display shows the new setting for the selected schedule.
-



---

**Lights**

Shortcut: 064xnn  
 where nn is schedule  
 number and x is light  
 number minus 1

Default: Off

This setting lets you attach light controls to a time schedule.

To attach schedules to lights:

1. Press A or B until the display shows ATTACH SCHEDULES TO EVENTS.
2. Press # then A or B until the display shows LIGHTS. Press # to enter the Lights menu.
3. Press A or B until the light appears.
4. Press # and the display shows SCHEDULE 00 OFF/ON (current setting). If you want a different schedule, press A or B until the desired schedule appears.
5. Press 1 (off) or 2 (on). The display flashes the entered selection. Press # and the display shows the new setting for the selected schedule.
6. Repeat the process until all desired lights are attached to schedules.

---

**Outputs**

Shortcut: 065xnn  
 where nn is schedule  
 number and x is output  
 number minus 1

Default: Off

This setting lets you attach outputs to a time schedule. Onboard outputs are 1 to 2; SnapCard outputs are 3 to 6.

Only onboard and SnapCard outputs can be scheduled. These outputs can only be scheduled if output text has been entered in installer programming and if the output is assigned to the same partition as the touchpad used.

To attach schedules to outputs:

1. Press A or B until the display shows ATTACH SCHEDULES TO EVENTS.
  2. Press # then A or B until the display shows OUTPUTS. Press # to enter the Outputs menu.
  3. Press A or B until the output appears.
  4. Press # and the display shows SCHEDULE 00 OFF/ON (current setting). If you want a different schedule, press A or B until the schedule appears.
  5. Press 1 (off) or 2 (on). The display flashes the entered selection. Press # and the display shows the new setting for the selected schedule. Repeat the process until all desired outputs are attached to schedules.
-

---

<b>Arming</b>	This setting lets you arm according to a time schedule. This setting will allow you to arm to away only. There is no disarm schedule.
Shortcut: 0660nn where nn is schedule number	To attach schedules to arming:
Default: Off	<ol style="list-style-type: none"> <li>1. Press A or B until the display shows ATTACH SCHEDULES TO EVENTS.</li> <li>2. Press # then A or B until the display shows ARMING.</li> <li>3. To select arm to Away press #.</li> <li>4. Press # and the display shows SCHEDULE 00 OFF/ON (current setting). If you want a different schedule, press A or B until the schedule appears.</li> <li>5. Press 1 (off) or 2 (on). The display flashes the entered selection. Press # and the display shows the new setting for the selected schedule.</li> <li>6. Repeat the process until all desired schedules are attached.</li> </ol>

---

## Energy saver menu

The Energy saver menu lets you set the energy saver module or dialog RF thermostat low- and high-setpoints. These setpoints override the premises thermostat allowing the energy saver module or dialog RF thermostat to activate the furnace/air conditioner.

---

<b>Low setpoint</b>	This setting determines the temperature at which the energy saver module relay closes to activate the furnace. The low setpoint cannot be set equal to or higher than the high setpoint. Enter the desired temperature (45 to 89°F).
Shortcut: 070	
Default: 50°F	
<b>High setpoint</b>	This setting determines the temperature at which the energy saver module relay closes to activate the air-conditioner. The high setpoint cannot be set equal to or lower than the low setpoint. Enter the desired temperature (46 to 90°F).
Shortcut: 071	
Default: 90°F	

---

## Attach lights to sensors menu

This menu lets you assign a light number to a sensor. Each time the sensor is activated, the attached light will turn on for 5 minutes. When the 5-minute timer expires, the light will turn off. If the same light is scheduled, it will only turn on during the schedule time.

---

<b>Light X to Sensor Y</b>	This menu attaches light x to sensor y. Each time a selected sensor is tripped, the selected light will turn on and a 5-minute timer will start. The sensor must be learned into the current partition before it can be attached.
Shortcut: 08n where n is light number minus 1	
Default: 0	
	To attach a light to a sensor:
	1. With the display showing LIGHT 1 TO SENSOR y (current setting), press A or B to select the light number.
	2. Enter the sensor number (01 to 96). The display flashes the entered setting. Press # and the display shows the new setting.
	3. Repeat the process until all desired lights are attached to sensors.
	To detach a light from a sensor:
	1. With the display showing LIGHT 1 TO SENSOR y (current setting), press A or B to select the light number.
	2. Enter 0 as the sensor number and press #.

---

## System version menu

The System version menu lets you view and identify panel hardware and software. This information is primarily used for troubleshooting purposes.

---

<b>System version</b>	This menu lets you view and identify panel hardware and software version.
Shortcut: 010 (factory code), 011 (system number), 012 (system level), 013 (software version)	To view and identify the system version:
	1. Press A or B until the display shows SYSTEM VERSION.
	2. Press # and the display shows FACTORY CODE nnn*nnnn.
	3. Press B and the display shows SYSTEM NUMBER *nnnnnnn.
	4. Press B again and the display shows SYSTEM LEVEL nnnn.
	5. Press B again and the display shows SW VERSION nnnnx (panel firmware version).

---

## Downloader programming

The panel can be programmed remotely using Enterprise Downloader. Use the information you recorded in Appendix A “System planning sheets” on page 117 to inform the downloading operator of the programming requirements for this system.

A Downloader phone number should be programmed and the user-programmable option Downloading must be powered on for remote downloader programming to work.

**To initiate an Enterprise Download session:**

1. Contact your download station and ask the operator to prepare to download to the panel.
2. Make sure the system is disarmed.
3. Press 8, *system master code*, 7, 0 (any), 1 (down) or 2 (up). The display shows `SYSTEM DOWNLOAD IN PROGRESS` during the downloading process.

If the alphanumeric touchpad does not display `SYSTEM DOWNLOAD IN PROGRESS`, call the downloader operator to verify the downloader phone number. Also, make sure Enterprise ToolBox is set up properly.

These programming options can only be edited with Enterprise Toolbox:

SIA False Alarm Enabled  
Auto Stay Arming Enabled

# Chapter 4

# Testing and troubleshooting

## Summary

This chapter provides information to help you test and troubleshoot the system.

## Content

**Error! Bookmark not defined.**

## Testing the system

Before testing, we recommend that you close the panel cabinet door and the covers on all modules (mounted outside the cabinet.) The testing environment should match the system working environment.

You should test the system after installation or service and after adding or removing devices from the system. See “Cellular backup communication” on page 104 if you do not achieve correct test results.

Testing the system includes:

- “Basic system commands” below
- “Zones/sensors” on page 97
- “Phone communication” on page 98
- “Central station/pager communication” on page 99
- “Outputs and sirens” on page 100
- “Light control” on page 101
- “Energy saver module (ESM)” on page 101
- “Fixed display LCD touchpad chime and trouble beep tones” on page 102
- “Audio verification module communication” on page 103
- “Cellular backup communication” on page 104

### Basic system commands

Table 14 below describes basic touchpad operating commands. For complete details on system operation, including user programming, refer to the Concord 4 User Manual.

**Table 14: Basic touchpad commands**

Command	System response
* (STATUS)	Indicates current system status
*, *	Indicates AC power, battery, and current system status
1, <i>code</i>	Disarms system to OFF
2, <i>code</i>	Arms system to STAY
2 (quick arm on)	Arms system to STAY
3 (quick arm on)	Arms system to AWAY
2 or 3, <i>code</i> , 4 or 2 or 3, 4	Arm system—no delay (no exit or entry delay)
5, 2 or 3, <i>code</i> or 5, 2 or 3	Arms system silently (no arming status beeps)

Command	System response
* (STATUS)	Indicates current system status
7, 1	Turns chime feature on and off
7, 2	Turns energy saver on and off
7, 4	Partition jump without entering code (only if partition security option is off)
7, 6	Identifies alarms in memory
7, 7, n (n = output number [1to6]) 1 to 2 = onboard outputs; 3 to 6 = module outputs	Turns the output on or off. (This command is only functional after output text is entered into panel memory.)
8, <i>code</i> , 2	Initiates a phone test
8, <i>code</i> , 3	Initiates a sensor test
8, <i>installer code</i> , 3	Initiates a dealer sensor test
8, <i>code</i> , 6	Partition jump
8, <i>code</i> , 8	View event history
0, 0	Turns all controlled lights on and off
0, n (n = light number 1 to 9)	Turns individual controlled light on and off

## Zones/sensors

Test sensors/zones after all programming is completed; whenever there is a change in environment, equipment, or programming; and whenever a zone- or sensor-related problem occurs.

If the system does not respond as described in the following procedure, see Troubleshooting.

**Note:** While the sensor test is a valuable installation and service tool, it only tests sensor operation for the current conditions. You should perform a sensor test after any change in environment, equipment, or programming.

### To test zones/sensors:

1. Place all sensors and zones in their nonalarm state.
2. At an alphanumeric touchpad, enter the sensor test mode by pressing 8, *installer code*, 3. The touchpad sounds one beep and displays SENSOR TEST. The panel starts a 15-minute timer.
3. Trip each zone/sensor one at a time. Touchpads (and interior sirens) should sound one short, high-pitched beep, and the display should show the sensor name (or number) and OK.

4. Press the Status button when you think all zones/sensors are tested. The touchpad displays any untested sensors/zones and touchpad panics. If all sensors/zones and touchpad panics have been tested, the display shows `SENSOR TEST OK`.
5. Test any untested zones/sensors and touchpad panics.  
**Note:** If you hear a long, low-pitched beep, proceed to “If a wireless sensor does not test” below.
6. The system stays in sensor test mode for 15 minutes. When less than 5 minutes remain, touchpads and interior sirens beep and the panel announces the remaining time over the speakers once every minute. After 15 minutes, the panel disarms to off automatically. If you need more time to complete the sensor test, press 8, *installer code*, 3 while the system is still in sensor test mode. This restarts the 15 minutes of test time.
7. When all sensors/zones and touchpad panics have been tested, press 1, *installer code* to exit sensor test mode.

#### **If a wireless sensor does not test**

If touchpads display `SENSOR FAILURE` and sirens sound a long, low-pitched beep when a zone or sensor is tripped, this indicates that the wireless sensor signal strength is below acceptable limits affecting the sensor signal strength.

When possible, locate wireless sensors within 100 ft. of the panel. While a transmitter may have a range of 1,000 ft. (3000 m) or more out in the open, the environment at the installation site can have a significant effect on transmitter range. See Troubleshooting to resolve the problem.

For wireless sensors that don't respond, use an RF Sniffer (60-401) test tool to verify that the sensor is transmitting. Constant beeps from the RF Sniffer indicate a runaway (faulty) sensor. Remove the sensor batteries and replace the sensor.

## **Phone communication**

Do a phone test to check the phone communication between the panel and the central monitoring station.

#### **To test phone communication:**

1. Contact the central monitoring station to inform them that you are testing the system.
2. Press 8, *system master code*, 2. The display reads `PHONE TEST` and the touchpad sounds one beep. When the panel completes the test, the system returns to the previous arming level automatically.



3. If the display continues to show `PHONE TEST` for 90 seconds or more, enter 1, *system master code* and see Troubleshooting.

## Central station/pager communication

After doing sensor and phone tests, check that the system is reporting alarms successfully to the central station or pager.

---

**Caution:** Be sure to contact the central monitoring station before activating outputs that trigger from an alarm condition.

---

Account numbers vary when displayed, depending on pager service. Account numbers are not displayed if Streamlining is turned on.

### To test communication with the central station/pager:

1. Call the central station and tell the operator that you will be testing the system.
2. Arm the system.
3. Test each of the touchpad and wireless panic buttons and trip at least one sensor of each type (fire, intrusion, etc.) to verify correct operation.
4. Check pager displays to verify reports are received. Pagers display an event code, digit sensor number, and the last four digits of the account number. A pager display of 999 002 7468 indicates the following:
  - 999 (alarm condition)
  - 002 (sensor/zone in alarm or user number)
  - 7468 (last four digits of account number)
5. When you finish testing the system, call the central monitoring station to verify they received the alarms.

Table 15 below describes pager system event codes

**Table 15: Pager system event codes**

Codes	System event
009	Zone restoral
111	System disarmed
115	Sensor test exit
118	Trouble condition cleared
119	Alarm canceled
222	System armed to STAY

<b>Codes</b>	<b>System event</b>
333	System armed to AWAY
555	Phone/sensor test
888	System trouble condition
999	System in alarm

Table 16 below describes pager sensor/zone number and user number report codes.

**Table 16: Pager sensor/zone code and numbers**

<b>Code</b>	<b>Sensor/zone or user number</b>
000	System event not caused by a zone or user
001–096	Sensor/zone numbers 1 to 96
600–829	Regular user codes 0 to 229 used
830-837	Partition master code used
838-845	Partition duress code used
846	System master code used
847	Installer code used
848	Dealer code used
850	Quick arm used
851	Keyswitch sensor used
852	System armed itself (during service or power-up)

## Outputs and sirens

You should test all outputs (onboard and SnapCard) to verify configuration programming.

**Note:** Be sure to contact the central monitoring station before activating outputs that trigger from an alarm condition.

### To test outputs:

1. Contact the central monitoring station to inform them you are testing the system.
2. Verify that all wiring at the panel and output devices is correct.
3. Activate the appropriate device to trigger each output as programmed.

4. Verify that each output responds according to the programmed configuration number. For outputs that trigger sirens, verify that the correct alarm sounds are produced from these sirens (see Table 17 below).
5. Contact the central monitoring station when you are finished testing.

Table 17 below describes the system alarm sounds you should hear for each alarm event.

**Table 17: System alarm sounds**

Alarm type	Alarm sound
Fire	Repeating series of three beeps
Police/Intrusion	Continuous tone
Auxiliary	Rapid beeps

## Light control

Test all lights plugged into X10 lamp modules to verify house code and light number settings.

### To test light control:

1. Press 0, 0 repeatedly to turn all lights on and off together.
2. Press 0, 1 repeatedly to turn light 1 on and off.
3. Repeat step 2 for remaining lights (0 + 2 for light 2, 0 + 3 for light 3, etc.).
4. Arm the system to away. All lights plugged into modules set to unit 1 (or set as entry lights) should turn on and stay on for 5 minutes. All lights plugged into modules set to unit 2 should blink three times to indicate the arming level. Remaining lights should not be affected.
5. Disarm the system. If unit 1 (or entry) lights were on for an entry or alarm, they will turn off in 5 minutes. Unit 2 lights should blink once to indicate the system is off. Remaining lights should not be affected.
6. All lights should turn on and remain on during fire and auxiliary/medical alarms. All lights should flash during a police or intrusion alarm.

## Energy saver module (ESM)

Test the energy saver module to verify it overrides the thermostat.

**Note:** The system must have high- and low-temperature limits set to test the energy saver module.

### To test the energy saver module:

1. Press \*, \* to display the system status, ENERGY SAVER OFF, and the present TEMPERATURE nn°. The temperature displayed (and/or announced) should match the house thermostat. If the temperatures do not match, refer to “Accessory modules - bus device settings” on page 73.

**Note:** There is a 5-minute delay after the energy saver module returns control to the furnace/AC before it will override the furnace/AC again.

2. Press 7, 2 to turn on the ESM. The display shows ENERGY SAVER ON and the ESM relay will click once.
3. Press 7, 2 again to turn the ESM off. The display shows ENERGY SAVER OFF.

### Fixed display LCD touchpad chime and trouble beep tones

You can adjust the frequency (pitch) of chime and trouble beep tones from a fixed display touchpad to a more desirable or distinct tone, or to compensate for hearing impaired persons.

#### To change status tone pitch:

1. Press and hold the \* and 0 buttons together until you hear a steady tone, then release the buttons.

**Note:** Chime and trouble beep tones sound using the default frequency during, or within 15 seconds of, any button activity at that specific touchpad.

2. Press and hold 1 to lower the pitch or press and hold 2 to raise the pitch.
3. Release the button when the desired pitch is heard.

After about 15 seconds of no touchpad activity, the steady tone stops sounding.

### Touchpad display contrast

You can adjust touchpad displays for easier viewing to help compensate for lighting conditions in the touchpad location. The contrast adjustment lightens or darkens the text. (Vacuum fluorescent displays do not have a contrast adjustment.)

#### To adjust display contrast:

1. Enter configuration mode by pressing the D and 6 buttons together for at least 2 seconds. The display shows DA nnn.

2. Press and release the 1 and 2 buttons together repeatedly, until the desired contrast level is displayed.
3. Press \* and the display briefly shows `DONE`, and then shows the time and date.

## Audio verification module communication

Test the audio verification module (AVM) from offsite and the central station to verify that it works properly.

You will need a helper and DTMF phone at an offsite location to perform this test. When testing the AVM from offsite you must follow these guidelines:

- Set the remote access feature to on (default).
- Set the audio verify feature to on.
- Set the system to a nonalarm state.
- Set the optional ring/hang/ring feature (default) to work with steps 1 and 2 below. Otherwise wait for 12 rings and the panel will pick up automatically.

### To test the module from offsite:

1. The offsite helper calls the panel, lets the phone ring twice, and hangs up.
2. The helper must call the panel again in 10 to 40 seconds. The panel answers System hello. This works if you have a phone interface voice module (part #60-777-01) installed.
3. The helper dials the following on the phone, #, 1234, #, 8 (*AVM access CODE*), 5.
4. The helper should now be able to hear you through the AVM.
5. Walk through the vicinity of the AVM while speaking at a normal conversation level.
6. Tell the helper to dial a 1 and speak to you. To return to listen mode, the helper dials a 3.
7. When testing is complete, have the helper dial 99 and hang up.

### To test the module with the central station:

1. Inform the central station that you will be sending an alarm and testing an AVM.
2. Give them the programming selections you made for the panel.
3. Use a panic button to initiate an auxiliary alarm.

4. The central station operator waits for the alarm to be reported and initiates an audio session.
5. Walk through the vicinity of the AVM while speaking at a normal conversation level.
6. Have the operator speak to you.
7. When testing is complete, the operator will end the session.

## Cellular backup communication

To check the cellular communication between the panel and the central monitoring station:

1. Contact the central monitoring station to inform them that you are testing the system.
2. Install and activate the SuperBus 2000 cellular backup module.
3. Verify or change the following CS phone panel option settings shown in “Cellular backup communication” above.

**Note:** If the current settings do not match the test settings, record the current settings (Table 17 on page 101), so that they can be restored when this test is complete.

4. Disconnect the phone line by unplugging the DB-8 cord from the RL 31X jack.
5. Initiate a phone test (8, *system master code*, 2).
6. The phone test attempt should fail via the phone line within 5 minutes. The panel will emit a long low tone (and speak “phone failure 1” if so equipped).
7. Wait for the phone test to succeed via the cell backup. The panel should emit a short high tone (and speak “phone test okay” if so equipped).
8. Verify the CS report.
9. If success does not occur, verify that the signal strength (RSSI) shown on the cellular backup module is acceptable and repeat the process.

**Table 18: Cellular backup communication**

CS phone 1 option	Test setting	Previous setting
Phone number	Central station phone number	
High level reports	On	
Backup	Off*	
Cellular backup	On	

\*Can be set to On if no CS phone 2 phone number is programmed.



# Troubleshooting

This section provides information to help you diagnose and solve various problems that may arise while configuring or using your UTC Fire & Security product.

- “Panel power issues” below
- “Access code issues” on page 108
- “Arming and disarming issues” on page 108
- “Bypassing issues” on page 109
- “Wireless sensor and touchpad battery issues” on page 109
- “Central station/pager reporting issues” on page 109
- “Alphanumeric touchpad issues” on page 110
- “Fixed display touchpad issues” on page 110
- “Speaker issues” on page 111
- “Siren issues” on page 111
- “Hardwired zone issues” on page 112
- “Wireless sensor zone issues” on page 112
- “Wireless touchpad issues” on page 113
- “Phone issues” on page 113
- “Light control issues” on page 114
- “Energy saver module issues” on page 114
- “Automation module issues” on page 115

## Panel power issues

### Concord 4 transformers

Concord 4 uses a 16.5 VAC transformer, (600-1023 or 600-1024 with power line carrier). Concord 3 uses a 24 VAC transformer. Using a 24 VAC transformer on Concord 4 damages the panel.

### **The panel does not power up and touchpads don't display or respond.**

- Verify that the panel transformer is plugged into an unswitched outlet.
- Check the AC circuit breaker to be sure the circuit is live.
- Check that the backup battery is installed correctly and the AC power transformer is plugged in.
- Check for proper panel and transformer wiring.
- Measure the incoming AC voltage at panel terminals 1 and 2. It should read about 16.5 VAC.



**No incoming AC voltage at panel terminals 1 and 2.**

1. Unplug the AC power transformer and disconnect the wires from the transformer and the panel.
2. Check transformer to panel wire for short or open circuits.
3. Plug in the transformer and check for 16.5 VAC at the transformer unconnected terminals. If it shows zero (0) volts, replace the transformer.

---

**WARNING:** Do not check for voltage by touching two live wires together. This may damage the transformer.

---

**Touchpad display indicates System Low Battery or voice sounds, “System low battery.”**

- Check that the backup battery is installed correctly and the AC power transformer is plugged in.
- Measure the incoming AC voltage at panel terminals 1 and 2. It should read about 16.5 VAC.
- Check for 11.75 to 13.8 VDC battery voltage between the backup battery spade lugs. If the battery voltage is not within this range, replace the battery.

**Note:** When the panel is running a backup battery test, the reading at the connected battery can range from 11.2 to 13.5 VDC. The panel automatically runs a backup battery test under the following conditions: (1) on initial power-up, (2) during user sensor test, (3) once every minute when backup battery has failed, (4) once every 24 hours at the programmed STIME (UL 98 Options off) or once every 4 hours (UL 98 Options on).

With the AC power transformer plugged in, the panel automatically charges the battery. While the battery is charging for the first time, it is normal for the system to indicate System Low Battery. This can take a number of hours depending on the initial battery charge. Once the battery reaches 12.5 VDC (full charge as measured while in battery test), the condition clears. If the trouble condition persists after 24 hours, replace the backup battery.

**The touchpads flash AC or display AC Power Failure/AC Failure After pressing STATUS the panel continues to operate from backup battery.**

- Check the AC circuit breaker to be sure the circuit is live.
- Check for proper panel and transformer wiring.
- Check that the transformer is plugged into a nonswitched outlet and secured with the provided screw.

- Check that the transformer is supplying AC to the panel.

---

**WARNING:** Be careful when securing the transformer to an outlet with a metal cover. Hold the cover tightly in place. You could receive a serious shock if the metal outlet cover drops down onto the prongs of the plug while you are securing the transformer and cover to the outlet box.

---

## Access code issues

### Customer cannot remember access codes.

- Check your records to see if you have the customer's access codes on file.
- Verify the access codes using the Enterprise Downloader software.
- Clear memory and reprogram the panel locally. Clearing the memory erases all programming.

### Installer cannot remember install code.

- Check your records to see if you have the install code on file.
- Verify the install code using the Enterprise Downloader software.
- Use the dealer code to enter program mode and view the installer code.

### Installer cannot remember dealer code.

Check your records to see if you have the dealer code on file. If you don't have dealer codes, you need to replace the panel.

## Arming and disarming issues

### System protests and won't arm.

- If arming to level 2, make sure all monitored perimeter doors and windows are closed.
- If arming to level 3, make sure all perimeter and interior sensors are closed.
- Press STATUS for an indication of the problem.

### System won't disarm.

- You may be trying to disarm using an incorrect code. Verify correct code and enter it.
- Access code is not programmed or set up in user programming to disarm system. Wireless touchpad is not learned into system or hardwired touchpad is not communicating to panel.
- The installer code is being used to disarm the system. The system is designed not to disarm using the installer code. Use a regular or system master code to disarm the system.

### System won't arm to Level 3 away when arming from a touchpad.

### It does arm to Level 3 (away) with a keyfob or 3rd party mobile app.

- When arming to Level 3 (away) you must exit through a standard exit delay door. If not the system will arm to Level 2 (Stay).

## Bypassing issues

**Touchpad indicates Invalid and/or “Invalid” is heard when you attempt to bypass a sensor.**

- You may be attempting to bypass a 24-hour sensor that cannot be bypassed (group 26 fire sensors).
- The sensor is not active in the current arming level.
- Arm the system to the desired arming level, then bypass.

**System cancels sensor bypass when you try to arm to Level 2 or 3.**

Sensor is being bypassed before arming to Level 2 stay or Level 3 away. Arm to the desired level before bypassing a sensor.

## Wireless sensor and touchpad battery issues

**System indicates Sensor/Touchpad nn low battery.**

Replace the indicated device battery and test the sensor/touchpad after replacing the battery.

## Central station/pager reporting issues

**Trouble with your central station or pager.**

Check the programming, panel connections, and proper phone line with line seizure.

To check your programming:

1. Make sure you enter the correct phone number.
2. Make sure you enter the correct account number.
3. Check that the appropriate format is chosen (SIA or CID).
4. Make sure the appropriate reports are turned on.

To check your panel connections:

1. Concord panels are polarity sensitive, so check for proper polarity:

The positive green lead or (TIP) wires must connect to terminal 25 on the board.

The negative red lead or (RING) wires must connect to terminal 28 on the board.

2. Concord panels are voltage sensitive, so it's necessary to check for proper voltage:

On hook voltage should be approximately 48-52 volts.

Off hook voltage should be approximately 6-10 volts.

**Note:** The Concord panel has a built-in line voltage meter. If it does not see proper voltage, it will not dial on a tone phone line. This does not apply to a pulse phone line.

To check proper phone line with line seizure:

1. Check the type of phone line. Concord panels work with analog phone lines or DSL with a DSL filter inline to the panel. VOIP or digital phone lines may not work with the panels.
2. Check that the premise's phone line is working.
3. Check that the DB-8 cord is plugged into the RJ31X/CA-38A jack.
4. Check for correct phone line wiring between the TELCO block and the RJ31X/CA-38A jack.

## Alphanumeric touchpad issues

### **Display shows all \*\*\*\*\*.**

Touchpad is not connected to panel bus terminals or is wired incorrectly. Check and correct wiring.

### **Display is blank.**

- Check that panel is powered up.
- Check for touchpad power and/or incorrect bus wiring, opens, or shorts.
- Check the touchpad brightness setting. (See Options menu on page 108.)

### **Touchpad buttons don't beep when pressed.**

- Check for touchpad power and/or incorrect bus wiring, opens, or shorts.
- Check that key beeps option is set to on. (See the Accessory modules - bus device settings on page 93.)

## Fixed display touchpad issues

### **Display is lit but does not respond to key presses.**

- Touchpad is not connected to panel bus terminals or is wired incorrectly. Check and correct wiring.
- Check that touchpad is learned into panel memory.

### **Display is blank.**

- Check that panel is powered up.
- Check for touchpad power and/or incorrect bus wiring, opens, or shorts.
- Check the touchpad brightness setting. (See the user-programming Options menu on page 108.)

### **Touchpad buttons don't beep when pressed.**

- Check for touchpad power and/or incorrect bus wiring, opens, or shorts.
- Check that key beeps option is set to on. (See the Accessory modules - bus device settings on page 93.)

## **Speaker issues**

### **Speakers don't sound alarms.**

- Speaker output has shut down because panel detected terminal 7 or 8 is shorted to ground. Disconnect panel AC and battery backup power. Locate short and correct. Apply panel AC and backup battery power and retest.
- Alarm is in partition 2 to 6 and speaker is connected to panel terminals 7 and 8, which activate only for partition 1 alarms.

## **Siren issues**

### **Piezo sirens connected to SnapCard, or onboard (panel) outputs 1 and/or 2 don't produce any alarm sounds.**

- Check for incorrect wiring between siren and panel, and correct where necessary.
- Output has not been configured (set up) to activate sirens. Enter program mode and configure output. (See Accessory modules - bus device settings on page 93.)
- Check for correct output partition assignment.
- Check that your wires are connected to the appropriate terminals:  
 Output 1 (exterior) uses terminals 9 (positive) and 13 (ground).  
 Output 2 (interior, follows status beeps) uses terminals 11 (positive) and 10 (ground).

## Hardwired zone issues

### System doesn't go into alarm when zone is tripped.

- System is disarmed. Arm system and then trip the zone.
- Zone is not learned into panel memory. Enter installer/dealer program mode—LEARN SENSORS, and learn zone into memory.
- Zone is learned into wrong partition. Delete zone and learn into correct partition or change the partition in the EDIT SENSORS menu.
- For Hardwire Input Module (HIM) zones, check that the HIM LED is blinking to verify communication with the panel. If LED is off, check wiring between HIM and panel.

### Zone reports trouble condition.

- Check that onboard, HIM, and SnapCard zone inputs have a 2 kohm EOL resistor installed at the last device on the loop in series for NC loops, in parallel for NO loops.
- Check for zone wire fault—short circuit on NC loops, open circuit on NO loops.

## Wireless sensor zone issues

### System doesn't respond (in sensor test or when armed) when sensor is tripped.

- Verify that receiver antennas are routed through holes on top of enclosure and antenna shrouds are installed.
- Check that the wireless sensor batteries are installed.
- Check the sensor batteries for low voltage. Replace batteries if necessary.
- Use an RF Sniffer (60-401) to verify that sensor is transmitting.
- Sensor is not learned into panel memory. Enter installer/dealer program mode—LEARN SENSORS, and learn sensor into memory.
- Zone is learned into wrong partition. Delete zone and learn into correct partition or change the partition in the EDIT SENSORS menu.

### Sensor reports trouble condition.

- Sensor tamper switch is tripped—sensor cover is off, not latched securely, or sensor is not mounted securely. Secure sensor mounting and/or cover, then trip sensor to clear the condition.
- Check the sensor battery for low voltage. Replace batteries, if necessary.

**Touchpad indicates [sensor #] supervisory.**

- Use an RF Sniffer (60-401) to verify that sensor is transmitting. If sensor is not transmitting, check battery for low or no voltage and replace.
- Change mounting position of sensor (from horizontal to vertical or vice versa) and test sensor several times for consistency.
- Sensor signal is not reaching panel/receiver because sensor is too far away. Remove sensor from mounted location and test from other locations. Mount sensor in area where signal can reach panel/receiver or install a SuperBus 2000 RF transceiver near the sensor. You may also install a Repeater 80-922-1 to boost signal.

**Smoke sensor beeps intermittently.**

Sensor batteries are getting low. Replace batteries.

**Wireless touchpad issues****System doesn't respond to commands entered from wireless touchpad.**

- Verify that receiver antennas are routed through holes on top of enclosure and antenna shrouds are installed.
- Check that touchpad batteries are properly installed.
- Check the touchpad batteries for low voltage. Replace batteries, if necessary.
- Use an RF Sniffer (60-401) to verify that touchpad is transmitting.
- Touchpad is not learned into panel memory. Enter program mode and learn touchpad into memory (see Sensors menu on page 85).
- Touchpad is learned into wrong partition. Delete touchpad and learn into correct partition or change the partition in the Sensors menu on page 85.

**Touchpad reports trouble condition.**

Check the touchpad batteries for low voltage. Replace batteries, if necessary.

**Phone issues****Loss of dial tone at onsite phones after wiring RJ31X jack or connecting the DB-8 cord.**

- Wait two minutes and try again. The panel may be busy trying to report to the central station.
- Disconnect the panel DB-8 cord from the RJ31X jack. If the phone still doesn't work, the system is okay and the problem is in the wiring.

- Check RJ31X jack wiring and TELCO block wiring. Replace RJ31X jack if necessary.
- Check DB-8 cord connections at the panel and RJ31X jack. Replace cord if necessary.
- Perform a phone test after troubleshooting the phone line.

### **Constant dial tone, preventing dial-out on premises phones.**

One or more polarity-sensitive phones exist on-site. Reverse the phone wires connected to the brown and gray wire terminals on the RJ31X jack.

## **Light control issues**

### **Light controlled by X10 lamp module is not working.**

- Partition house codes are not programmed into panel. Enter program mode and set partition house codes.
- Check that the HOUSE dial on the X10 module matches the partition house code programmed into the panel.
- Panel is not powered by a power line carrier transformer. Replace existing transformer with a power line carrier transformer.
- Check to make sure X10 module is not plugged into an outlet controlled by a switch. Move to a nonswitched outlet location and test.
- Check that the lamp has a working bulb and that the lamp switch is on.
- Power transformer and X10 modules are not plugged into outlets on the same electrical phase. Relocate modules or transformer to different outlets to determine working locations.

## **Energy saver module issues**

### **Module does not respond to system commands or appear to control furnace.**

- Check that the module is wired correctly to the panel terminals.
- Verify the module LED is flashing continuously. If the LED is not flashing, remove power and check wiring.
- There is a 5-minute delay after the module returns control to the furnace/AC thermostat, before the module overrides the thermostat again. Wait 5 minutes and try again.

### **Module temperature does not match actual room temperature.**



The module room temperature setting has not been adjusted or was adjusted before the module warmed or cooled to room temperature. To ensure accuracy, wait at least 15 minutes after installing the module before adjusting the temperature. To adjust the module room temperature setting, see Temperature under “Accessory modules - bus device settings” on page 73.

## Automation module issues

**Module is not controlling or communicating with the panel and panel indicates a “BUS FAILURE UNIT nn” where nn is the automation module bus unit number.**

- Check that the module is wired correctly to the panel terminals.
- Verify the SuperBus module’s red LED is flashing continuously. If the LED is not flashing, remove power and check wiring.
- Check that the RS-232 cable is firmly connected to the automation module and the automation device.
- Verify the automation device is powered and turned on.

**Module is not controlling or communicating with the panel and panel does not indicate a bus failure.**

Verify the automation module is learned into panel memory.



# Appendix A

## System planning sheets

### **Summary**

This appendix provides various system planning sheets for the Concord 4.

### **Content**

**Error! Bookmark not defined.**

## Customer information

**Table 19: Customer information**

Customer name	
Address	
City	
County	
State	
Zip	
Phone	

## Wireless devices

**Table 20: Wireless devices**

Part number	Description	Quantity
60-362	Door/window sensor	
60-670-95R	SAW door/window sensor	
60-741-95	Micro recessed door/window sensor	
60-499	Slim line door/window sensor	
60-688	Micro door/window sensor	
60-641	Long-life door/window sensor	
60-461	Shock sensor	
60-459	Sound sensor	
60-462	Glass guard sensor	
60-506	System sensor smoke sensor	
60-838-95R	2100ARFT smoke sensor	
60-848-02-95	ESL 562 smoke sensor	
60-460	Rate-of-rise heat sensor	
60-589	Manual fire pull sensor	
60-504	Freeze sensor	
60-452	Pendant panic sensor	
60-458	Single button panic sensor	

Part number	Description	Quantity
60-457	Dual button panic sensor	
60-578	Water-resistant panic sensor	
60-511-01-95	DS924i PIR motion sensor	
60-639-95R	SAW indoor PIR motion sensor	
60-639-95R-OD	SAW outdoor PIR motion sensor (not for intrusion protection)	
60-703-95	Crystal indoor PIR motion sensor	
60-834-95R	Adjustable dual technology sound sensor	
60-597	HiTech handheld wireless touchpad	
60-607	Two-button keyfob touchpad	
60-606	Four-button keyfob touchpad	
60-659-95R	SAW four-button keyfob touchpad	
60-832-95R	Two-button ELM keyfob touchpad	

## Hardware devices

**Table 21: Hardware devices**

Part number	Description	Quantity	mA (max.)	Subtotal
<b>Hardwire sensors/detectors</b>				
	System sensor models 2400, or 2400TH or ESL series 429AT, 429C, 429CT, 521B, 521BXT, 521NCSXT, 711U, 711UT, 721U, 721UT, TS7-2, or TS7-2T		80 mA*	
13-082	PIR motion detector		10 mA	
<b>Sirens</b>				
13-046	Hardwire exterior siren		145 mA	
13-949	Hardwire interior siren		85 mA	
13-950	Piezo dynamic exterior siren		150 mA	
<b>SuperBus 2000/miscellaneous components</b>				
60-746-01	2x16 LCD alphanumeric touchpad		90 mA	
60-820	Fixed display LCD touchpad		65 mA	
600-1020	FTP 1000		75 mA	
60-803	2x20 LCD alphanumeric touchpad		120 mA	

Part number	Description	Quantity	mA (max.)	Subtotal
60-804	2x20 VFD alphanumeric touchpad		120 mA	
60-983	ATP 1000		110 mA	
60-984	ATP 2600		165 mA	
60-985	ATP 2100		300 mA	
600-1013	GTS 50		300 mA	
60-836	Voice only module (with current jumper installed) / (with current jumper removed)		300 mA / 600mA	
60-777-01	Phone interface/voice module		600 mA	
600-1019	2-amp power supply		N/A	
60-756	4 input/2 output SnapCard		185 mA	
60-757	8Z hardwired zone expander SnapCard		230 mA	
60-758	4 output SnapCard		130 mA	
60-774	Hardwired input module		35 mA	
60-770	Hardwired output module		180 mA	
60-620-01	Energy saver module		20 mA	
60-850	Cellular backup module (standard power)		10 mA	
60-850-01	Cellular backup module (high power)			
60-861	Wireless cellular gateway		1900 mA	
60-677	Interrogator 200 audio verification module		1600 mA	
60-783-02	Automation module		10 mA	
60-528	Hardwired interior speaker		35 mA	
13-060	15-watt speaker		500 mA	

**Total power consumption:** mA

**Total power consumption not to exceed:** 1,000 mA

\* Total current only for all two-wire smoke detectors connected to panel two-wire smoke loop.

# Zone and sensor assignments

**Table 22: Zone and sensor assignments**

No.	RF zone	Module bus ID number	Module input number	Group	Partition	Zone/sensor text
1						
2						
3						
4						
5						
6						
7						
8						
9						
10						
11						
12						
13						
14						
15						
16						
17						
18						
19						
20						
21						
22						
23						
24						
25						
26						
27						
28						
29						

Appendix A: Systemplanning sheets

No.	RF zone	Module bus ID number	Module input number	Group	Partition	Zone/sensor text
30						
31						
32						
33						
34						
35						
36						
37						
38						
39						
40						
41						
42						
43						
44						
45						
46						
47						
48						
49						
50						
51						
52						
53						
54						
55						
56						
57						
58						
59						
60						
61						



No.	RF zone	Module bus ID number	Module input number	Group	Partition	Zone/sensor text
62						
63						
64						
65						
66						
67						
68						
69						
70						
71						
72						
73						
74						
75						
76						
77						
78						
79						
80						
81						
82						
83						
84						
85						
86						
87						
88						
89						
90						
91						
92						
93						

No.	RF zone	Module bus ID number	Module input number	Group	Partition	Zone/sensor text
94						
95						
96						

## System settings index and record

**Table 23: System settings index and record**

Setting reference (default)	Shortcut number	Setting
Installer programming—8, <i>installer/dealer code</i> , 00		
24-hour tamper (Off)	06000	
AC failure (Off)	06011	
Access code lock (On)	0003	
Access timeout (90 seconds)	09004	
Account number (00000)	0010 to 0060	
Activity timeout (24 hours)	0305	
Alarm verify (Off)	06108 to 06608	
Antenna tamper (Off)	06001	
Audio mode (1)	09001	
Audio verify (Off)	09000	
Auto phone test (Off)	02001	
Auto test reset (On)	02002	
Auxiliary panic (On)	0511 to 0561	
Auxiliary power fail (On)	06016	
AVM access code (None)	09006	
Back in service (On)	06003	
Backup CS phone 1 (On) CS phone 2-3 (Off)	01005, 01015, 01025	1 _____ 2 _____ 3 _____
Battery restoral (Off)	06006	
Beep delay (2 seconds)	09005	
Buffer control (Off)	06002	
Buffer full report (Off)	06007	

Setting reference (default)	Shortcut number	Setting
Bypass reports (Off)	06004	
Call wait cancel (None)	02009	
Cancel message (On)	02007	
Cellular backup CS phone 1 (On), CS phone 2-3 (Off)	01007, 01017, 01027	1 _____ 2 _____ 3 _____
Cellular system (B)		
Closing reports (Off)	06101 - 06601	
Comm. failure (On)	02003	
CS phone 1 to 3 (None)	01000, 01010, 01020	
Daylight saving (On)	0307	
Dealer code (None)	0002	
Delete sensors (None)	082	
Dial tone detect (On)	02010	
Dial abort delay (30 seconds)	02006	
Disable trouble beeps (Off)	0701	
Downloader code (12345)	0000	
Downloader phone number (None)	01090	
DTMF dialing (On)	02004	
Duress code (None)	0016 to 0066	
Duress option (Off)	06103 to 06603	
Edit sensors (None)	083	
Entry delay (30 seconds)	0310 to 0360	
Exception reports phones (Off)	01003, 01013, 01023	1 _____ 2 _____ 3 _____
Exception reports pagers (Off)	01033, 01043, 01053, 01063, 01073	1 _____ 2 _____ 3 _____ 4 _____ 5 _____
Exit delay (60 seconds)	0311 to 0361	
Exit extension (On)	0013 to 0063	
Extended delay (4 minutes)	0312 to 0362	
Fire panic (On)	0510 to 0560	
Fire shutdown (Off)	09002	
Force armed (Off)	06104 to 06604	
Freeze alarm (Off)	06106 to 06606	
Freeze temp (42)	06107 to 06607	

Setting reference (default)	Shortcut number	Setting
Global fire (Off)	0703	
Ground fault (On)	06017	
High level reports (phones) CS phone 1 (On), CS phone 2-3 (Off)	01001, 01011, 01021	1 _____ 2 _____ 3 _____
High level reports pagers (On)	01031, 01041, 01051, 01061, 01071	1 _____ 2 _____ 3 _____ 4 _____ 5 _____
House code (1B, 2C, 3D, 4E, 5F, 6G)	0401 to 0451	
Immediate beeps (Off)	0700	
Installer code (4321)	0001	
Keyfob arming (Off)	0513 to 0563	
Keyfob PTN	0006	
Keyswitch sensor (None)	0014 to 0064	
Keyswitch style (Transition)	0015 to 0065	
Latchkey format (Off)	06105 to 06605	
Latchkey reports pagers (On)	01035, 01045, 01055, 01065, 01075	1 _____ 2 _____ 3 _____ 4 _____ 5 _____
Latchkey zones (None)	0500	
Learn sensors (None)	080	
Line fail delay (None)	0213	
Local phone control (On)	0210 to 0260	
Low CPU battery (On)	06005	
Low level reports CS phone 1 (On), CS phone 2-3 (Off)	01002, 01012, 01022	1 _____ 2 _____ 3 _____
Low level reports pagers (Off)	01032, 01042, 01052, 01062, 01072	1 _____ 2 _____ 3 _____ 4 _____ 5 _____
Manual mic gain	09009	
Multiple-partition arm (Off)	0005	
Next phone test (7 days)	0304	
No activity (Off)	06102 to 06602	
Open/close reports phones (Off)	01004, 01014, 01024	1 _____ 2 _____ 3 _____
Open/close reports pagers (Off)	01034, 01044, 01054, 01064, 01074	1 _____ 2 _____ 3 _____ 4 _____ 5 _____

Setting reference (default)	Shortcut number	Setting
Opening reports (Off)	06100 to 06600	
Onboard output 1 (01614 - any audible alarm)	11101	
Onboard output 2 (01710 - status and alarm tones)	11111	
Output trip time (4 seconds)	0305	
Pager delay (15 seconds)	02008	
Pager partition assignment (1)	01037, 01047, 01057, 01067, 01077	1 _____ 2 _____ 3 _____ 4 _____ 5 _____
Pager phone 1 to 5 (None)	01030, 01040, 01050, 01060, 01070	1 _____ 2 _____ 3 _____ 4 _____ 5 _____
Partition security (On)	0004	
Phone access key (#)	0216 to 0266	
Phone panic (Off)	0215 to 0265	
Phone test (On)	02000	
Phone test frequency (7 days)	0303	
Police panic (On)	0512 to 0562	
Program report (Off)	06015	
Quick arm (Off)	0011 to 0061	
Quick exit (On)	0012 to 0062	
Receiver failure (Off)	06012	
Remote access (On)	0211 to 0221	
RF low battery rpt (Weekly)	06013	
RF supervisory rpt (Weekly)	06014	
RF TX timeout (12 hours)	0302	
Ring/hang/ring on	0212 to 0262	
Reporting format (SIA/CID)	01006, 01016, 01026	1 _____ 2 _____ 3 _____
Sensor text (None)	081	
Silent talkback (Off)	09003	
Siren timeout (4 minutes)	0313 to 0363	
Siren verify (Off)	0710	
Sleep time (Off)	0314 to 0364	
Smoke verify (Off)	1100	

Setting reference (default)	Shortcut number	Setting
SnapCard output 1 (01400 - keyfob star button activation)	101101	
SnapCard output 2 (00410 - any audible alarm)	101111	
SnapCard output 3 (00903 - arming to stay or away)	101121	
SnapCard output 4 (01003 - arming to away)	101131	
Star is no delay (Off)	0514 to 0564	
Streamlining (On)	01036, 01046, 01056, 01066, 01076	1 _____ 2 _____ 3 _____ 4 _____ 5 _____
Supervisory time (03:00)	0300	
Swinger limit (1)	06015	
System tamper (Off)	06109 to 06609	
Toll saver (On)	0214 to 0264	
TP panic RPT FMT (Off)	06010	
Two-trip error (Off)	06009	
Two-wire smoke (Off)	1101	
UL 98 options (Off)	0702	
VOX gain range	09008	
VOX mic gain	09007	
VOX RX gain	09010	
Zone restorals (Off)	06008	

# Appendix B

## Reference tables

### **Summary**

This appendix provides reference tables and specifications.

### **Content**

**Error! Bookmark not defined.**

## Sensor group characteristics

Table 24 below shows what the sensors on your Concord 4 system do. Every sensor is assigned to a group, and this table specifies those groups and functions. Every device must be assigned to one of these groups.

**Table 24: Sensor group characteristics**

#	Name	Application	Alarm	Delay	Restoral	Supervisory	CS Report	Chime (Level)	Active levels
00	Fixed panic	24-hour audible fixed emergency buttons.	Police	Instant		✓	✓		1,2,3
01	Portable panic	24-hour audible portable emergency buttons.	Police	Instant			✓		1,2,3
02	Fixed panic	24-hour silent fixed emergency buttons.	Silent	Instant		✓	✓		1,2,3
03	Portable panic	24-hour silent portable emergency buttons.	Silent	Instant			✓		1,2,3
04	Fixed auxiliary	24-hour auxiliary sensor, such as Pendant Panic or holdup button.	Auxiliary	Instant		✓	✓		1,2,3
05	Fixed auxiliary	24-hour auxiliary emergency button. Siren shutoff confirms CS report.	Auxiliary	Instant		✓	✓		1,2,3
06	Portable auxiliary	24-hour portable auxiliary alert button.	Auxiliary	Instant			✓		1,2,3
07	Portable auxiliary	24-hour portable auxiliary button. Siren shutoff confirms CS report.	Auxiliary	Instant			✓		1,2,3
08	Special intrusion	Special belongings, such as gun cabinets and wall safes.	Police	Instant	✓	✓	✓		1,2,3
09	Special intrusion	Special belongings (i.e. gun cabinets and wall safes.)	Police	Standard	✓	✓	✓		1,2,3
10	Entry/exit delay	Entry and exit doors that require a standard delay time.	Police	Standard	✓	✓	✓	✓	2,3
11	Supplementary Extended Delay	Garage doors and entrances that require an extended delay time. <sup>1</sup>	Police	Extended	✓	✓	✓	✓	2,3



#	Name	Application	Alarm	Delay	Restoral	Supervisory	CS Report	Chime (Level)	Active levels
12	Supplementary Extended Delay	Driveway gates and entrances that require a twice extended delay time. <sup>1</sup>	Police	Twice extended	✓	✓	✓	✓	2,3
13	Instant perimeter	Exterior doors and windows	Police	Instant	✓	✓	✓	✓	2, 3
14	Instant interior	Interior doors (Hardwired)	Police	Follower	✓	✓	✓		2,3
15	Instant interior	Interior PIR motion sensors. (RF wireless)	Police	Follower		✓	✓		2,3
16	Instant interior	Interior doors. (Hardwired)	Police	Follower	✓	✓	✓		3
17	Instant interior	PIR motion sensors (RF wireless.)	Police	Follower		✓	✓		3
18	Instant interior	Instant interior cross-zone# PIR motion sensors. *	Police	Follower		✓	✓		3
19	Delayed interior	Interior doors that initiate a delay before going into alarm.	Police	Interior	✓	✓	✓		3
20	Delayed interior	PIR motion sensors that initiate a delay before going into alarm.	Police	Standard		✓	✓		3
21	Local instant interior	24-hour local alarm zone protecting anything that opens and closes.	Police	Instant	✓	✓			1,2,3
22	Local delayed interior	Same as group 21, plus activation initiates a delay before going into alarm.	Police	Standard	✓	✓			1,2,3
23	Local instant auxiliary	24-hour local alarm zone protecting anything that opens and closes.	Auxiliary	Instant	✓	✓			1,2,3
24	Local instant auxiliary	24-hour local alarm zone protecting anything that opens and closes. Sirens shut off at restoral.	Auxiliary	Instant	✓	✓			1,2,3
25	Local special chime	Notify the user when a door is opened. Sounds emit from a local annunciator.	Special chime	Instant		✓			1,2,3

#	Name	Application	Alarm	Delay	Restoral	Supervisory	CS Report	Chime (Level)	Active levels
26	Fire	24-hour fire, rate-of-rise heat, and smoke sensors.	Fire	Instant	✓	✓	✓		1,2,3
27	Output module	Hardwire Output Module (HOM) lamp control or other customer feature.	Silent	Instant	✓	✓			1,2,3
28	Output module	HOM, PIR motion sensor, sound sensor or pressure mat.	Silent	Instant		✓			1,2,3
29	Auxiliary	Freeze sensor.	Auxiliary	Instant	✓	✓	✓		1,2,3
32	Output module	HOM, PIR motion sensor, sound sensor or pressure mat.	Silent	Instant					1,2,3
33	Siren	Wireless siren supervision.	Silent	Instant		✓	✓		1,2,3
34	Gas	Carbon monoxide (CO) gas detectors	Auxiliary	Instant	✓	✓	✓		1,2,3
35	Local instant police (day zone)	Local alarm in levels 1 and 2. Report to CS in level 3.	Police	Instant	✓	✓	✓ (Level 3 only)		1,2,3
38	Auxiliary	Water sensor.	Auxiliary	Instant	✓	✓	✓		1,2,3

Note: Check marks (✓) represent characteristics present in a group.

\* Sounds instant police siren if two or more sensors are tripped within 4 minutes. Otherwise, sensors are followers to delayed sensors. If Alarm Verification is on, group 18 functions like group 17.

1. Does not satisfy Auto Stay Arming exit requirement

## Cross-zoning

*Cross-zoning* (two-trip) refers to two different group 18 sensors that must be tripped within two minutes of each other to report an alarm to the central station. Figure 28 below shows the path of a person walking from the kitchen to the living room. When the person is detected walking through the kitchen, the motion sensor in the kitchen is tripped, sounding a local alarm. If motion is detected by the living room motion sensor within two minutes, an alarm report will be sent to the central station.

Figure 28: Cross-zone diagram

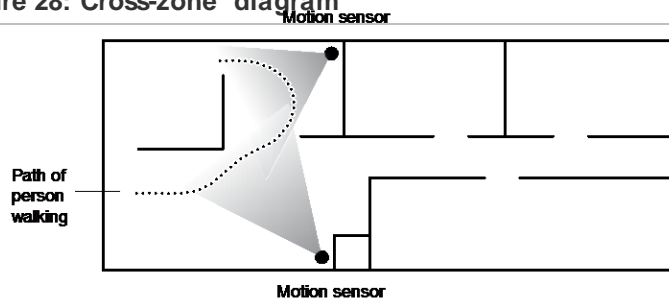

**Note:** We do not recommend cross-zoning for exit/entry zones. Each zone can individually protect the intended area.

## Extended Delay Zones

Sensor groups 10, 11 and 12 were designed as one path. The system will arm various areas as you leave the premises.

Example: Exiting the premise.

1. Open and close the premise entry exit door (Group 10).  
The system arms premise after the Standard delay has expired. (30-240 secs)
  2. Open and close a garage door (Group 11). System adds this zone to the already armed system at the end of the extended delay time. (1-8 mins)
  3. Drive over a driveway sensor (Group 12). System adds this zone to the already armed system and the end of the twice extended delay time. (2-16 mins)
- Upon entering, the system uses the lowest entry time as a zone is opened.

Example: Entry exit door (Group 10) entry time is programmed for 30 secs and Garage door (Group 11) entry time is programmed for 6 mins.

1. When the garage door has been opened the panel must be disarmed within 6 minutes.
2. If the entry exit door is opened after 2 minutes the entry exit (Group 10) delay starts. The panel must be disarmed within 30 seconds. There must be a Sensor Group 10 zone used with either a Sensor Group 11 or 12 zone for the system to arm to Level 3 (away) from a touchpad. This is due to the Auto Stay Arming option that is enabled in the system.

**Note:** The Auto Stay Arming feature can be disabled user the Enterprise Download Software. Please refer to the "Downloading" section of this manual.

## Sensor text

Table 25 below provides sensor text with the applicable item number.

**Table 25: Item numbers and sensor text**

Item #	Sensor text	Item #	Sensor text	Item #	Sensor text	Item #	Sensor text
001	Aborted	061	Entry	121	North	181	Up
002	AC	062	Error	122	Not	182	West
003	Access	063	Exit	123	Now	183	Window
004	Active	064	Exterior	124	Number	184	Zone
005	Activity	065	Factory	125	Off	185	0
006	Alarm	066	Failure	126	Office	186	1
007	All	067	Family	127	OK	187	2
008	AM	068	Father's	128	On	188	3
009	Area	069	Feature	129	Open	189	4
010	Arm	070	Fence	130	Opening	190	5
011	Armed	071	Fire	131	Panic	191	6
012	Arming	072	First	132	Partition	192	7
013	Attic	073	Floor	133	Patio	193	8
014	Auxiliary	074	Force	134	Pet	194	9
015	Away	075	Foyer	135	Phone	195	A
016	Baby	076	Freeze	136	Please	196	B
017	Back	077	Front	137	PM	197	C
018	Bar	078	Furnace	138	Police	198	D
019	Basement	079	Gallery	139	Pool	199	E
020	Bathroom	080	Garage	140	Porch	200	F
021	Battery	081	Gas	141	Power	201	G
022	Bedroom	082	Glass	142	Press	202	H
023	Bottom	083	Goodbye	143	Program	203	I
024	Breezeway	084	Hallway	144	Progress	204	J
025	Building	085	Heat	145	Quiet	205	K
026	Bus	086	Hello	146	Rear	206	L
027	Bypass	087	Help	147	Receiver	207	M
028	Bypassed	088	High	148	Report	208	N

Item #	Sensor text	Item #	Sensor text	Item #	Sensor text	Item #	Sensor text
029	Cabinet	089	Home	149	RF	209	O
030	Canceled	090	House	150	Right	210	P
031	Car	091	In	151	Room	211	Q
032	Carbon Monoxide	092	Install	152	Safe	212	R
033	Central	093	Interior	153	Schedule	213	S
034	Chime	094	Intrusion	154	Screen	214	T
035	Closed	095	Invalid	155	Second	215	U
036	Closet	096	Is	156	Sensor	216	V
037	Closing	097	Key	157	Service	217	W
038	Code	098	Kids	158	Shed	218	X
039	Computer	099	Kitchen	159	Shock	219	Y
040	Control	100	Latchkey	160	Side	220	Z
041	Date	101	Laundry	161	Siren	221	(space)
042	Daughters	102	Left	162	Sliding	222	'(apostrophe)
043	Degrees	103	Level	163	Smoke	223	- (dash)
044	Delay	104	Library	164	Sons	224	_(underscore)
045	Den	105	Light	165	Sound	225	*
046	Desk	106	Lights	166	South	226	#
047	Detector	107	Living	167	Special	227	:
048	Dining	108	Load	168	Stairs	228	/
049	Disarmed	109	Loading	169	Stay	229	?
050	Door	110	Low	170	Supervisory		
051	Down	111	Lower	171	System		
052	Download	112	Main	172	Tamper		
053	Downstairs	113	Master	173	Temperature		
054	Drawer	114	Mat	174	Test		
055	Driveway	115	Medical	175	Time		
056	Duct	116	Memory	176	To		
057	Duress	117	Menu	177	Touchpad		
058	East	118	Mother's	178	Trouble		
059	Energy Saver	119	Motion	179	Unbypass		
060	Enter	120	No	180	Unit		

## System event triggers

Table 26 below describes the system event triggers.

**Table 26: System event trigger**

System event	Description	Trigger number
Null trigger (used for direct control)	Activates only by schedule or direct command.	000
Fire alarm	When fire sirens are started.	001
Police alarm	When police sirens are started.	002
Auxiliary alarm	When auxiliary sirens are started.	003
Any audible alarm	When any of the above sirens are started.	004
Silent alarm (sensor groups 2, 3, and duress)	When a group 2 or 3 sensor goes into alarm or when a duress alarm is activated (does not include groups 25, 27, 28, or 32).	005
Any audible or silent alarm	When any alarm is started (does not include groups 25, 27, 28, or 32).	006
HOM group 27, 28, 32 in alarm	When a sensor in group 27, 28, or 32 goes into alarm.	007
Major trouble (phone or receiver failure)	When a receiver failure (S94) or a phone failure (S96) occurs.	008
Arming to stay or away	When the system is armed to level 2 or 3.	009
Arming to away	When the system is armed to level 3.	010
AVM is interactive (audio session in progress)	When the central station operator begins listening or talking to the premises.	011
Fail-to-communicate (panel can't call CS or pager)	When the fail-to-communicate output is activated.	012
AVM trip (edge)	When an AVM alarm occurs, output is activated momentarily.	013
Keychain touchpad star button-press	When the star button on a keychain touchpad is pressed.	014
Smoke power (for resetting four-wire smoke detectors)	Deactivated when hardwire smoke detectors need to be reset.	015
Exterior siren	Activated for police or fire alarms.	016
Interior siren	Activation follows all system noises	017
AVM trip (pulse)	When an AVM alarm occurs, output is deactivated for 10 ms	018
State of system status	Follows the state of system status (ready or trouble).	019
Tamper condition	When any tamper is tripped	020

<b>System event</b>	<b>Description</b>	<b>Trigger number</b>
Closing report sent	When a closing report has been successfully transmitted to the central station.	021
Arming to Level 1	When the system is disarmed.	022
Group XX in alarm	When any sensor in group XX goes into alarm	
Sensor XX in alarm	When sensor number XX goes into alarm	
Sensor XX open	When sensor number XX is opened	

## Sensor group event triggers

Table 27 below describes the sensor group event triggers.

**Table 27: Sensor group event trigger numbers**

<b>Sensor group</b>	<b>Trigger number</b>	<b>Sensor group</b>	<b>Trigger number</b>
Group 00 in alarm	064	Group 17 in alarm	081
Group 01 in alarm	065	Group 18 in alarm	082
Group 02 in alarm	066	Group 19 in alarm	083
Group 03 in alarm	067	Group 20 in alarm	084
Group 04 in alarm	068	Group 21 in alarm	085
Group 05 in alarm	069	Group 22 in alarm	086
Group 06 in alarm	070	Group 23 in alarm	087
Group 07 in alarm	071	Group 24 in alarm	088
Group 08 in alarm	072	Group 25 in alarm	089
Group 09 in alarm	073	Group 26 in alarm	090
Group 10 in alarm	074	Group 27 in alarm	091
Group 11 in alarm	075	Group 28 in alarm	092
Group 12 in alarm	076	Group 29 in alarm	093
Group 13 in alarm	077	Group 30 in alarm	094
Group 14 in alarm	078	Group 31 in alarm	095
Group 15 in alarm	079	Group 32 in alarm	096
Group 16 in alarm	080	Group 35 in alarm	102

## Sensor number event triggers

Table 28 below describes the sensor number event triggers.

**Table 28: Sensor number event trigger numbers**

Sensor number	State	Trigger number	State	Trigger number
Sensor 01	In alarm	129	Open	257
Sensor 02	In alarm	130	Open	258
Sensor 03	In alarm	131	Open	259
Sensor 04	In alarm	132	Open	260
Sensor 05	In alarm	133	Open	261
Sensor 06	In alarm	134	Open	262
Sensor 07	In alarm	135	Open	263
Sensor 08	In alarm	136	Open	264
Sensor 09	In alarm	137	Open	265
Sensor 10	In alarm	138	Open	266
Sensor 11	In alarm	139	Open	267
Sensor 12	In alarm	140	Open	268
Sensor 13	In alarm	141	Open	269
Sensor 14	In alarm	142	Open	270
Sensor 15	In alarm	143	Open	271
Sensor 16	In alarm	144	Open	272
Sensor 17	In alarm	145	Open	273
Sensor 18	In alarm	146	Open	274
Sensor 19	In alarm	147	Open	275
Sensor 20	In alarm	148	Open	276
Sensor 21	In alarm	149	Open	277
Sensor 22	In alarm	150	Open	278
Sensor 23	In alarm	151	Open	279
Sensor 24	In alarm	152	Open	280
Sensor 25	In alarm	153	Open	281
Sensor 26	In alarm	154	Open	282
Sensor 27	In alarm	155	Open	283
Sensor 28	In alarm	156	Open	284



<b>Sensor number</b>	<b>State</b>	<b>Trigger number</b>	<b>State</b>	<b>Trigger number</b>
Sensor 29	In alarm	157	Open	285
Sensor 30	In alarm	158	Open	286
Sensor 31	In alarm	159	Open	287
Sensor 32	In alarm	160	Open	288
Sensor 33	In alarm	161	Open	289
Sensor 34	In alarm	162	Open	290
Sensor 35	In alarm	163	Open	291
Sensor 36	In alarm	164	Open	292
Sensor 37	In alarm	165	Open	293
Sensor 38	In alarm	166	Open	294
Sensor 39	In alarm	167	Open	295
Sensor 40	In alarm	168	Open	296
Sensor 41	In alarm	169	Open	297
Sensor 42	In alarm	170	Open	298
Sensor 43	In alarm	171	Open	299
Sensor 44	In alarm	172	Open	300
Sensor 45	In alarm	173	Open	301
Sensor 46	In alarm	174	Open	302
Sensor 47	In alarm	175	Open	303
Sensor 48	In alarm	176	Open	304
Sensor 49	In alarm	177	Open	305
Sensor 50	In alarm	178	Open	306
Sensor 51	In alarm	179	Open	307
Sensor 52	In alarm	180	Open	308
Sensor 53	In alarm	181	Open	309
Sensor 54	In alarm	182	Open	310
Sensor 55	In alarm	183	Open	311
Sensor 56	In alarm	184	Open	312
Sensor 57	In alarm	185	Open	313
Sensor 58	In alarm	186	Open	314
Sensor 59	In alarm	187	Open	315
Sensor 60	In alarm	188	Open	316
Sensor 61	In alarm	189	Open	317

<b>Sensor number</b>	<b>State</b>	<b>Trigger number</b>	<b>State</b>	<b>Trigger number</b>
Sensor 62	In alarm	190	Open	318
Sensor 63	In alarm	191	Open	319
Sensor 64	In alarm	192	Open	320
Sensor 65	In alarm	193	Open	321
Sensor 66	In alarm	194	Open	322
Sensor 67	In alarm	195	Open	323
Sensor 68	In alarm	196	Open	324
Sensor 69	In alarm	197	Open	325
Sensor 70	In alarm	198	Open	326
Sensor 71	In alarm	199	Open	327
Sensor 72	In alarm	200	Open	328
Sensor 73	In alarm	201	Open	329
Sensor 74	In alarm	202	Open	330
Sensor 75	In alarm	203	Open	331
Sensor 76	In alarm	204	Open	332
Sensor 77	In alarm	205	Open	333
Sensor 78	In alarm	206	Open	334
Sensor 79	In alarm	207	Open	335
Sensor 80	In alarm	208	Open	336
Sensor 81	In alarm	209	Open	337
Sensor 82	In alarm	210	Open	338
Sensor 83	In alarm	211	Open	339
Sensor 84	In alarm	212	Open	340
Sensor 85	In alarm	213	Open	341
Sensor 86	In alarm	214	Open	342
Sensor 87	In alarm	215	Open	343
Sensor 88	In alarm	216	Open	344
Sensor 89	In alarm	217	Open	345
Sensor 90	In alarm	218	Open	346
Sensor 91	In alarm	219	Open	347
Sensor 92	In alarm	220	Open	348
Sensor 93	In alarm	221	Open	349
Sensor 94	In alarm	222	Open	350

Sensor number	State	Trigger number	State	Trigger number
Sensor 95	In alarm	223	Open	351
Sensor 96	In alarm	224	Open	352

## System feature event triggers

Table 29 below describes the system feature event triggers.

**Table 29: System feature event trigger numbers**

Feature	State	Trigger number
Phone test	Initiated	225
AC failure	For 15 minutes	226
CPU low battery	Detected (excluding first minute after power-up)	227
Auto phone test	Begun	228
Receiver failure	Detected	229
Back in service	Alarm (AC loss, battery drain, then AC restore)	230
Phone failure	Detected	231
Buffer full	Detected	232
Two trip error	Detected	233
System tamper	Alarm (40 incorrect code entry keystrokes)	237
Freeze	Alarm	238
No activity	Alarm	239
Fire panic	Alarm	240
Police panic	Alarm	241
Auxiliary panic	Alarm	242
Opening report	Occurred	243
Closing report	Occurred	244
Latchkey opening or closing	Occurred	245
Duress	Alarm	246
Forced armed report	Occurred	247
Fire in partition	Alarm	248

Appendix B: Reference tables

<b>Feature</b>	<b>State</b>	<b>Trigger number</b>
Recent closing report	Occurred	249
Sensor test	Entered	251

## Response characteristics

Table 30 below describes the response characteristics.

**Table 30: Response characteristics**

Response characteristics	Description
Momentary trip time	The point remains active for nn seconds (n is 1 to 12 seconds). The default is 4 seconds.
3-minute trip time	The point remains active for 3 minutes.
Siren-time trip time	The point remains active while the sirens are sounding.
Sustained trip time	The point remains active for the duration of the event.
Siren pattern	The point activates and deactivates according to the current alarm type:  Auxiliary: fast on/off/on Police: constant on Fire: repeating
Trip delay	The point activates 30 seconds after the trigger event occurs.

## Response numbers

Table 31 below describes the response numbers.

**Table 31: Response numbers**

Response number	Siren tracking	Trip delay	Response time
00	No	No	Momentary
01	No	No	3 minutes [5]
02	No	No	Siren time [2]
03	No	No	Sustained [3]
04	No	Yes [4]	Momentary
05	No	Yes [4]	3 minutes [5]
06	No	Yes [4]	Siren time [2]
07	No	Yes [4]	Sustained [3]
08	Yes [1]	No	Momentary
09	Yes [1]	No	3 minutes [5]
10	Yes [1]	No	Siren time [2]

Response number	Siren tracking	Trip delay	Response time
11	Yes [1]	No	Sustained [3]
12	Yes [1]	Yes [4]	Momentary
13	Yes [1]	Yes [4]	3 minutes [5]
14	Yes [1]	Yes [4]	Siren time [2]
15	Yes [1]	Yes [4]	Sustained [3]

[1] If an event does not trigger sirens, siren tracking response numbers activate without turning on the output. If sirens are triggered by another event, the output pulses to match the siren. If the siren cadence changes (from police to fire, for example), outputs set up for siren tracking change to match the siren and all pulsing outputs pulse to one common cadence.

[2] If an event does not trigger sirens, siren time response times activate outputs only if sirens are active for another reason.

[3] If an alarm event does not necessarily require disarming (no activity, closing report, etc.), outputs set up for a sustained response time remain activated until the next arming level change.

[4] If an event occurs that activates an output set up for trip delay, the delay and output activation can be canceled by trigger event restoral.

[5] Activated outputs set up for a 3-minute response time remain active for the entire three minutes. To deactivate the output before the 3-minute time expires, you must enter program mode or remove panel power. Activated outputs set up for a momentary or 3-minute response time restart if the same trigger event occurs again.

**Note:** The mechanical lifetime of the relay may be exceeded if an output is set up for a siren tracking response and a pulsing siren (auxiliary or fire) is active for long periods. A SnapCard relay output's lifetime expectancy is about 350 total pulsing hours.

**Note:** The trip delay is factory set for 30 seconds and cannot be changed.

# Specifications

Power requirements	
Auxiliary power output	Class 2, 16.5 VAC, 40 VA, 60 Hz (part no. 600-1023 or 600-1024)
Batteries	Rechargeable 12 VDC, 4.5 or 5.0Ah Lead-Acid (part no. 60-681) OR 12 VDC, 7Ah (part no. 60-680). The battery will last 24 hours with no AC and specified standby load
Radio frequency	319.5 MHz
Nominal RF range	1,000 ft (305 m) typical open air
Storage temperature	- 30 to 140°F (-34 to 60°C)
Operating temperature	32 to 120°F (0 to 49°C)
Relative humidity	85% maximum noncondensing
Dimensions	14 x 12 x 3 in. (356 x 305 x 76 mm)





