



# UltraSync<sup>TM</sup>

## Modular Hub

**Security  
&  
Home Automation**

**REFERENCE MANUAL**

## About navigating this electronic document:

Throughout this document there are navigational links.

Wherever you see this symbol  you can click on it to *return* to the table of contents.

Wherever you see this symbol  you can click on it to *return* to the index.

Wherever you see [underlined blue text](#) you can click on it to *navigate* to that reference.

Whenever you navigate to a new page, you can *go back* using Alt + ← (left arrow)

PLEASE READ THE IMPORTANT SAFETY AND LEGAL INFORMATION INCLUDING WARNINGS, WARRANTY DISCLAIMERS, AND LIMITATIONS OF LIABILITY BEFORE USING THIS PRODUCT.

THIS INFORMATION CAN BE FOUND IN THE [PRODUCT WARNINGS](#) AND DISCLAIMERS SECTION BEGINNING ON PAGE 237.

# Contents

<b>Welcome</b> .....	<b>7</b>
Features & Benefits.....	7
System Capacity.....	7
<b>System Components</b> .....	<b>9</b>
1.1 CPU.....	9
1.2 Touch Screen Keypad.....	11
1.3 Zone Expansion Modules.....	12
1.4 Relay Expansion Modules.....	14
1.5 Wireless Expansion Modules.....	16
1.6 Cellular Module.....	17
1.7 Residential Plastic Enclosure.....	18
1.8 Commercial Metal Enclosure.....	19
1.9 Smart Power Supply.....	20
1.10 Batteries.....	27
1.11 Transformer.....	27
<b>2 Hardware Installation</b> .....	<b>29</b>
Minimum System Requirements.....	29
Choose a Location.....	29
2.1 Power Requirements.....	29
2.2 Grounding.....	30
2.3 Shielding.....	30
2.4 Termination Jumpers.....	30
2.5 Cable Requirements.....	30
2.6 Ferrite Installation.....	31
2.7 Wiring Diagram.....	32
2.8 Terminal Diagram.....	33
2.9 LED Diagram.....	34
<b>3 Programming Methods</b> .....	<b>35</b>
3.1 Programming via Web Server.....	36
3.1.1 Connect to LAN.....	36
3.1.2 Retrieve the CPU IP address.....	36
3.1.3 Manually Assign an IP Address.....	36
3.1.4 Login to the Web Server.....	37
3.1.5 Troubleshooting LAN Connections.....	37
3.2 Programming via UltraSync.....	37
3.2.1 Set Up a Web Access Passcode for UltraSync.....	37
3.2.2 Connect via UltraSync Application.....	38
3.2.3 Check LAN Connection to UltraSync Servers.....	40
3.2.4 Troubleshooting UltraSync Setup.....	41
3.3 Programming via DLX 900 Management Software.....	42
3.3.1 Enable Remote Access for DLX 900.....	42
3.3.2 Connect using DLX 900 on LAN.....	42
3.3.3 Remotely Connect using DLX 900 on UltraSync.....	42
3.4 Programming via On-Site Keypad.....	43
3.5 Recommended Items to Change.....	43
<b>4 The UltraSync App</b> .....	<b>45</b>
4.1 Install UltraSync App.....	45

4.1	Using the App .....	46
4.2	UltraSync Color Codes .....	49
<b>5</b>	<b>System Settings.....</b>	<b>51</b>
5.1	Learn in Sensors.....	51
5.2	Learn in a Keyfob.....	56
5.3	Programming Areas .....	59
5.4	Programming the System .....	62
5.5	Programming Reporting and Notifications .....	65
5.6	Programming the Network .....	67
5.7	Programming Automations (Scenes) .....	70
5.8	Programming Schedules .....	73
5.9	Programming Holidays .....	75
5.10	Lock PIN Share.....	77
5.11	Programming Cameras.....	78
	Add a Camera Method 1 – Automatic Discovery .....	78
	Viewing Cameras in UltraSync .....	78
5.12	Check Event History .....	79
5.13	Check Connection Status .....	80
5.14	Check Details.....	80
<b>6</b>	<b>Advanced Programming Using Web Server .....</b>	<b>81</b>
6.1	Advanced Programming, System .....	83
6.2	Advanced Programming, Sensors .....	94
6.3	Advanced Programming, Areas .....	98
	Notes on Force Arming, Bypass, and Auto-Bypass .....	102
6.4	Advanced Programming, Reporting and Notifications .....	109
	Configure Email Reporting.....	112
6.5	Advanced Programming, Communicator .....	113
6.6	Advanced Programming, Schedules.....	122
6.7	Advanced Programming, Actions.....	124
6.8	Advanced Programming, Auto Arm-Disarm .....	129
6.9	Advanced Programming, Devices and Enrollment.....	131
6.9.1	System Devices .....	131
6.9.1.1	Control Devices .....	132
6.9.1.1.1	Control Outputs.....	133
6.9.1.1.2	Enrollment.....	136
6.9.1.2	Keypads .....	139
6.9.1.3	Zone and Wireless Expansion Modules .....	142
6.9.1.4	Relay Expansion Modules .....	143
6.9.1.5	Smart Power Supply Modules .....	145
6.9.2	Interlogix Transmitters.....	147
6.9.3	Z-Wave Devices.....	148
6.9.4	Tablet Keypads .....	149
6.10	Advanced Programming, Permissions.....	150
6.11	Advanced Programming, Area Groups .....	154
6.12	Advanced Programming, Menus.....	155
6.13	Advanced Programming, Holidays.....	156
6.14	Advanced Programming, Sensor Types .....	157
	Sensor Types Table.....	160
6.15	Advanced Programming, Sensor Options.....	161
	Sensor Options Table .....	164
6.16	Advanced Programming, Event Lists.....	165

6.17	Advanced Programming, Channel Groups .....	166
	Customize Reporting Codes .....	168
	Reporting Fixed Codes in Contact I.D. ....	170
6.18	Advanced Programming, Action Groups.....	171
6.19	Advanced Programming, Scenes .....	171
6.20	Advanced Programming, Speech Tokens .....	173
6.21	Advanced Programming, Cameras.....	173
	Add a Camera Method 2 – Manual Entry.....	173
	Removing a Camera.....	173
6.22	Advanced Programming, Network Servers .....	174
<b>7</b>	<b>Users and Permissions .....</b>	<b>177</b>
7.1	Add Users.....	177
7.2	Users Submenus .....	179
7.3	Permissions .....	180
<b>8</b>	<b>Expansion Module Installation .....</b>	<b>183</b>
<b>9</b>	<b>Cellular Radio Setup.....</b>	<b>185</b>
9.1	Install Optional Cellular Radio.....	185
9.2	Check Signal Strength .....	187
9.3	Check cellular connection to UltraSync servers.....	189
<b>10</b>	<b>UltraSync Touchscreen Setup.....</b>	<b>191</b>
10.1	Quick Setup .....	191
10.2	Set up Wi Fi .....	192
10.3	Enroll the Touchscreen .....	193
10.4	Touchscreen Settings .....	194
10.5	Mounting.....	194
10.6	Upgrading Firmware .....	195
10.7	Other.....	195
<b>11</b>	<b>Camera Setup Instructions .....</b>	<b>197</b>
11.1	Quick Setup .....	197
11.2	Setting up Ethernet/Wi Fi transmission.....	197
11.3	Wi Fi Signal Strength .....	198
11.4	Add Camera via Wi Fi for iOS Device.....	199
11.5	Add Camera via Wi Fi for Windows PC .....	199
11.6	Add Camera via Ethernet for iOS Device (non DHCP) .....	200
11.7	Add Camera via Ethernet for Windows PC (non DHCP) .....	201
11.8	Add Camera via Ethernet (DHCP) .....	201
11.9	Add Camera to UltraSync .....	201
11.10	View Live Stream and Latest Clip .....	203
11.11	Program Event Triggered Camera Clips.....	203
11.12	View event triggered clips in History .....	205
11.13	Remove Camera from UltraSync (if needed) .....	205
11.14	Change Default Camera Settings (Via TruVision Navigator) .....	205
11.15	Camera Troubleshooting .....	206
<b>12</b>	<b>Arming and Disarming the System .....</b>	<b>207</b>
12.1	Keypress Tamper .....	207
12.2	Arm Your System in Away Mode .....	207
12.3	Arm Your System in Stay Mode.....	207
12.4	Disarm One or More Areas .....	208
12.5	Activate SOS Feature .....	208

<b>13 Glossary .....</b>	<b>209</b>
<b>Appendices .....</b>	<b>213</b>
A.1 DLX 900 Software.....	213
A.2 Troubleshooting DLX 900 .....	215
A.3 Firmware Upgrade using DLX 900.....	216
A.4 Voice Library.....	217
A.5 System Status Messages .....	218
A.6 App and Web Error Messages.....	219
A.7 Z-Wave Messages.....	220
A.8 History Events.....	221
A.9 Event Reporting Class Table .....	223
A.10 Action Events: Category and Types.....	224
A.11 Action Results Category and Action Results Event Types.....	225
A.12 System Building Blocks .....	226
A.13 System Menu Tree .....	228
A.14 Calculating Maximum Bus Cable Length .....	229
<b>Specifications .....</b>	<b>234</b>
S.1 CPU Power Input Specifications .....	234
S.2 System General Features .....	234
S.3 Current Consumption* .....	235
S.4 Battery Capacity Calculations .....	236
S.5 Environmental.....	237
S.6 Physical Dimensions.....	237
S.7 Fuses.....	237
S.8 Maintenance .....	237
S.9 System Monitoring .....	237
S.10 SIA and CID Reporting Code Descriptions .....	238
<b>UL Specification.....</b>	<b>243</b>
<b>Product Warnings.....</b>	<b>249</b>
Warranty Disclaimers .....	250
Disclaimer .....	250
Intended Use.....	250
Copyright.....	250
Trademarks and Patents .....	250
Manufacturer .....	251
Contact Information .....	251
Customer Support.....	251
Certification .....	251
Advisory messages .....	251
Regulatory Notices.....	252
<b>Index .....</b>	<b>253</b>

## Welcome

Please read through this document before starting the installation.

## Features & Benefits

With the ability to protect up to 500 zones, 96 areas and 256 users, the system can scale to meet requirements from small homes and businesses, even in demanding installations. The system can be fully customized to meet the needs of virtually any scenario.

## System Capacity

- 500 Zones
- 96 Areas
- 64 Keyfobs
- 64 Expansion Modules
- 192 Wireless Sensors
- 256 Users
- 128 User Permissions





## System Components

### 1.1 CPU

The CPU is the core component of the system and is the building block of every installation. There are eight on-board hardwired zones that can be zone doubled to 16. Alarm reporting and interactive services are supported by on board Ethernet connectivity. An optional cellular module is available to provide a cellular failover path in the event of a failure of the Ethernet connection. Additionally, a PSTN connection is available for alarm reporting. The default reporting path is over the Ethernet connection and PSTN reporting is disabled by default.



There are five on-board outputs supporting siren/speaker/strobe and smoke detector functionality. All are programmable via Actions.

Additional capacity and functionality can be added to the system with the addition of expansion modules via the encrypted RS-485 communication bus. Available expansion modules include keypads, hardwired zones, wireless sensors and relay devices.

The overall sensor capacity is a combination of hardwired and wireless sensors. Wireless sensor capacity is limited to 192. Keyfob capacity is 64 and is not affected by the number of wireless sensors that are learned into the system.

There are multiple ways to configure the system:

- A built in web server is available for simple web browser configuration
  - Local and remote access is supported
- UltraSync™ application for Android and Apple devices
- DLX 900 Upload/Download software
  - Local and remote access is supported
- UM-1820E touch screen keypad

## 1.2 Touch Screen Keypad

The UM-1820E touch screen keypad is the primary on-premise user interface. It has an intuitive user interface that allows the installer to fully configure the system. It also allows end users to interact with the security system based on their assigned permission level.



### 1.3 Zone Expansion Modules

Hardwired zone capacity of the system can be augmented using zone expansion modules. Eight and 20 zone versions are available. Flexible programming options allow the installer to maximize the efficiency of the zone expansion modules so the entire system capacity can be utilized. For example, if only five zones are hardwired to a zone expansion module, the system can be configured to only utilize those five zones from the module, leaving the remaining unused zones available for the system.

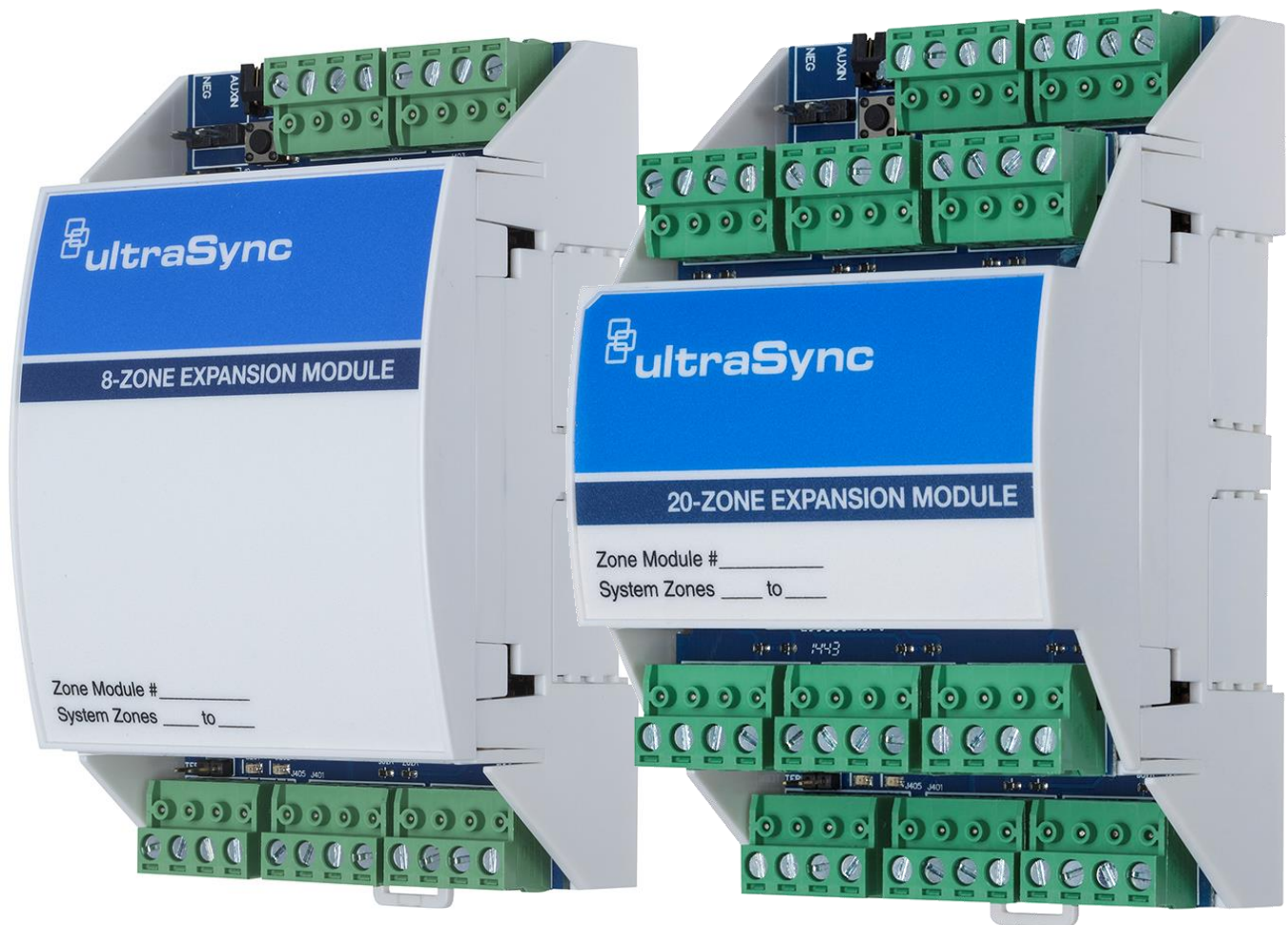

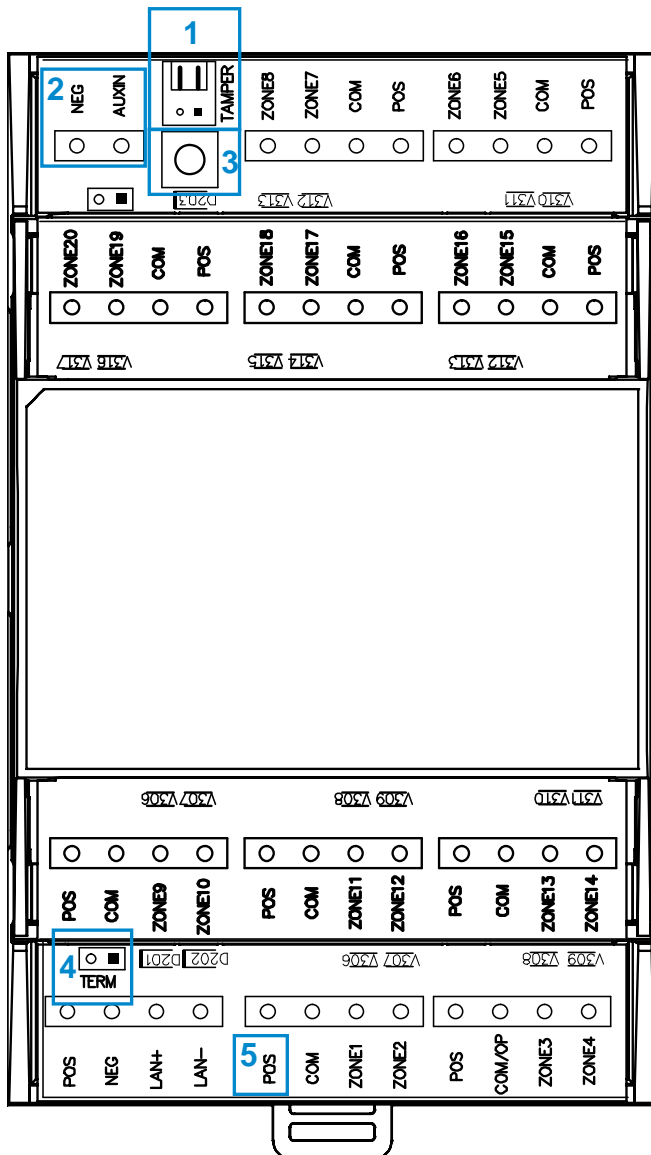

20 Zone Expander

1. Tamper input.  
Disabled by default. Connect tamper switch when mounted in a separate enclosure from CPU. Enable in \Devices\System Devices\Relay Expanders\Expander Options.
2. Neg, Aux, not used
3. Enroll button
4. Termination jumper
5. Power available on terminals for sensors.

Each zone expansion module must have its [Zone Start and End](#) programmed. To operate as a smoke detector reset, see [Expander Options](#). For details on enrolling Zone Expanders see [Enroll Function](#) in Advanced Programming, Devices and Enrollment.

## 1.4 Relay Expansion Modules

Hardwired relay output capability can be added to the system using relay expansion modules. Versions are available with 4 and 10 relays. Single Pole Double Throw (SPDT) Form C relays can be configured in 3 different modes to support different applications.

Flexible programming options allow the installer to setup manual control or automatically control the relays. Relays can be controlled based on events including but not limited to panel state, events (alarms, tamper, and trouble), low battery, AC, Cellular or Ethernet failure.

Each output module adds 32 more actions to the system. Seven output modules will provide a maximum of 256 actions.



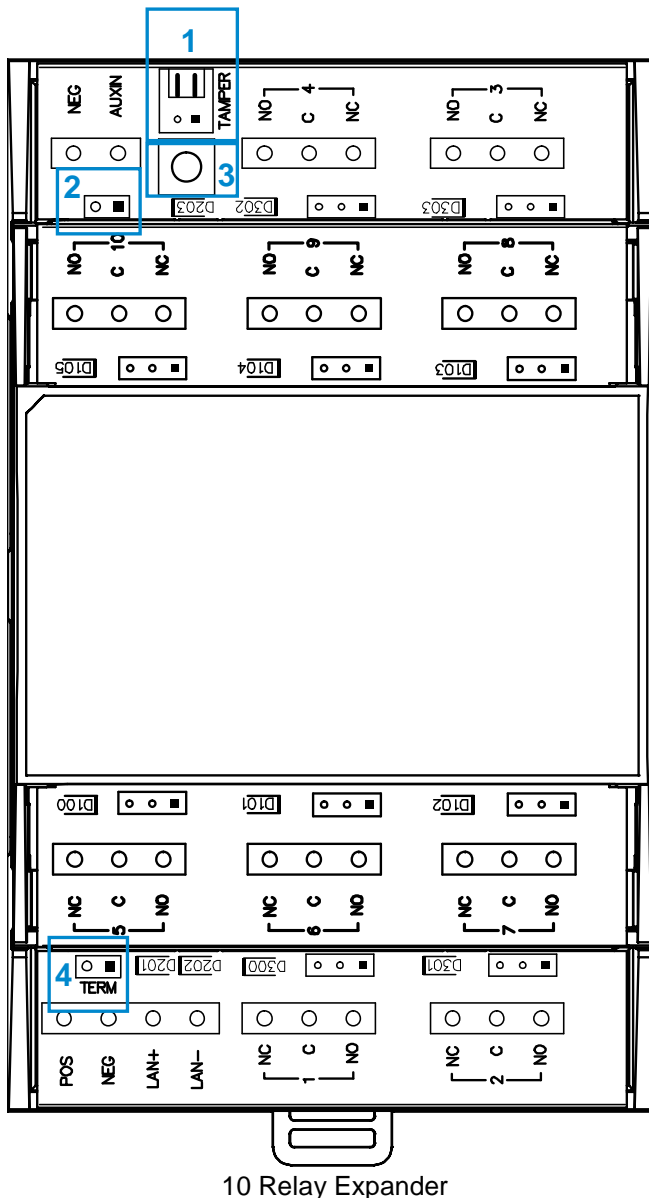

1. Tamper input.  
Disabled by default. Connect tamper switch when mounted in a separate enclosure from CPU. Enable in \Devices\System Devices\Relay Expanders\Expander Options.
2. Bus jumper  
Not installed – Relay Auxin comes from Auxin terminal.  
Installed – Relay Auxin is connected to LAN (bus) POS terminal.
3. Manual enroll button
4. Termination jumper

For details on enrolling Relay Output Expansion Modules, see [Enroll Function](#) in Advanced Programming, Devices and Enrollment.

Three switching modes are available on these relays; Dry Contact and Negative or Positive switching. For details see the relay installation sheet.

## 1.5 Wireless Expansion Modules

Wireless sensor capability of the system is added via the wireless sensor expansion module. In addition to providing wireless sensor capability to the system, the wireless expansion module also can provide support for two hardwired zones and one relay.

Up to 192 wireless sensors and 64 keyfobs are supported. Multiple wireless sensor expansion modules can be enrolled into the system to improve wireless reception performance; however, the overall wireless sensor capacity is not increased. Each sensor is learned into the CPU, not the module, greatly simplifying the installation process and improving overall system performance when multiple wireless expansion modules are installed:

- With two wireless expansion modules installed in close proximity to each other, redundancy is automatically built into the system (e.g. if one wireless receiver fails, the other will continue to receive wireless sensor transmissions).
- If a large coverage area is desired, multiple wireless expansion modules can be distributed throughout the area for expanded coverage purposes.

Wireless sensors will be received by multiple wireless expansion modules, providing a receive “diversity” benefit in a changing wireless environment. The CPU will process all sensor transmissions received from each wireless expansion module providing wireless sensors multiple reception paths to improve reliability and performance.





## 1.6 Cellular Module

An optional cellular radio module provides a backup communication path over a cellular network if the Ethernet or PSTN connection fails. This provides a plug and play connection with no configuration needed in most cases. The only requirement is good cellular reception. To connect via cellular service, you only need to install the cellular radio module and provision the panel for cellular service grade reporting in the UltraSync portal.

For details see the cellular module installation sheet.

---

**Note:** The cellular module is not a bus connected device. It installs directly to the CPU.

**Caution:** Electrostatic discharge may cause damage and void the warranty. Proper ESD precautions must be used during installation. Remove all power (AC and battery) to the CPU before proceeding. Failing to do so could result in possible damage to the product. System components should be kept in the antistatic packaging when not in use.

---



## 1.7 Residential Plastic Enclosure



The plastic enclosure features a DIN rail for mounting modules, a tamper switch, and integrated cable management.

The lid can be removed by releasing the two screws using the supplied Allen key.

The enclosure should be installed indoors under the following operating conditions:

- Temperature range: +32° to 120° F (0° to 49° C) for UL/ULC installations  
+14°F to 131°F (-10 to +55°C) for non-UL/ULC installations
- Humidity range:
  - Average 85% relative humidity, non-condensing for UL/ULC installations
  - Average 95% relative humidity, non-condensing for non-UL/ULC installations

## 1.8 Commercial Metal Enclosure

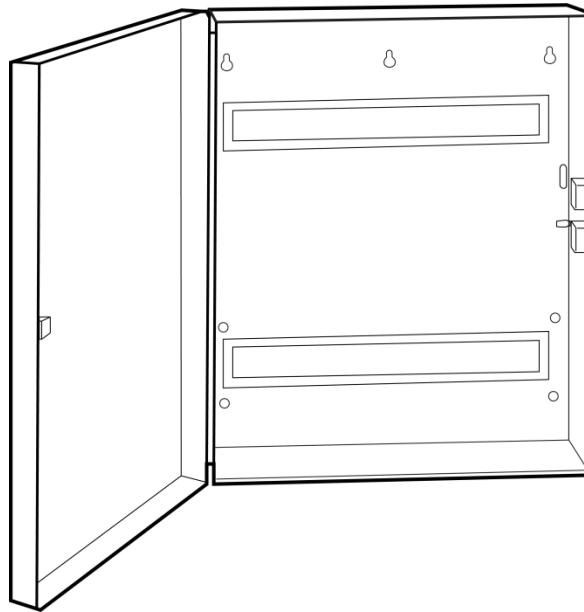

A metal enclosure is available for commercial applications, installations where additional zone and/or output expansion modules are required or situations where a larger backup battery is required. The UM-CME metal enclosure includes a tamper switch and two metal DIN rails.

The enclosure should be installed indoors under the following operating conditions:

- Temperature range: +32° to 120° F (0° to 49° C) for UL/ULC installations  
+14°F to 131°F (-10 to +55°C) for non-UL/ULC installations
- Humidity range:
  - Average 85% relative humidity, non-condensing for UL/ULC installations
  - Average 95% relative humidity, non-condensing for non-UL/ULC installations

## 1.9 Smart Power Supply

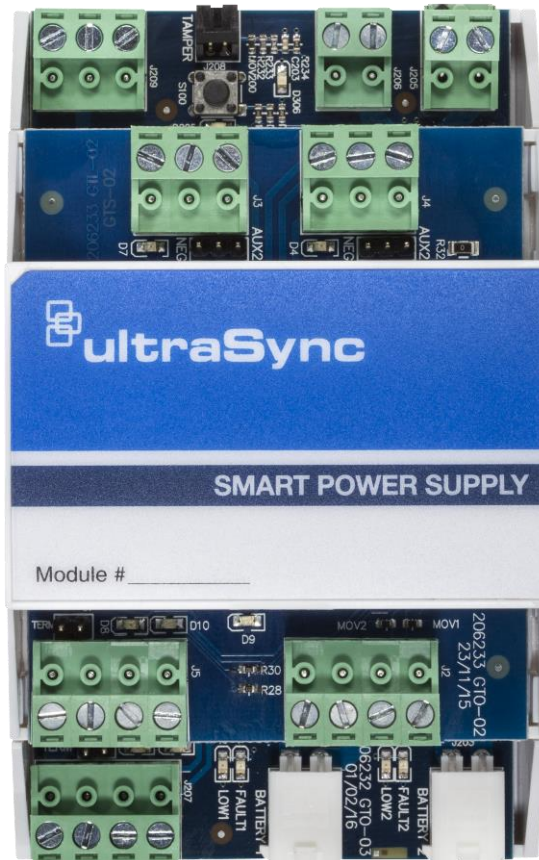

The UM-SPS smart power supply provides additional battery and current capacity to UltraSync Modular Hub installations. The smart power supply also offers two zone inputs and two programmable SPDT relay outputs. The module has a tamper connector that can be used to supervise the enclosure in which it is mounted. Both the main power input and batteries are monitored. The module provides the option to extend the RS-485 bus length up to an additional 2,600 ft. (800m). The extended RS-485 bus is optically isolated in this configuration.

Up to 8 smart power supplies can be used per system.

### Power Outputs

The smart power supply has three auxiliary power outputs to power three separate bus segments. The available current on each output is determined by the number of batteries that are connected to the unit. See below for details.

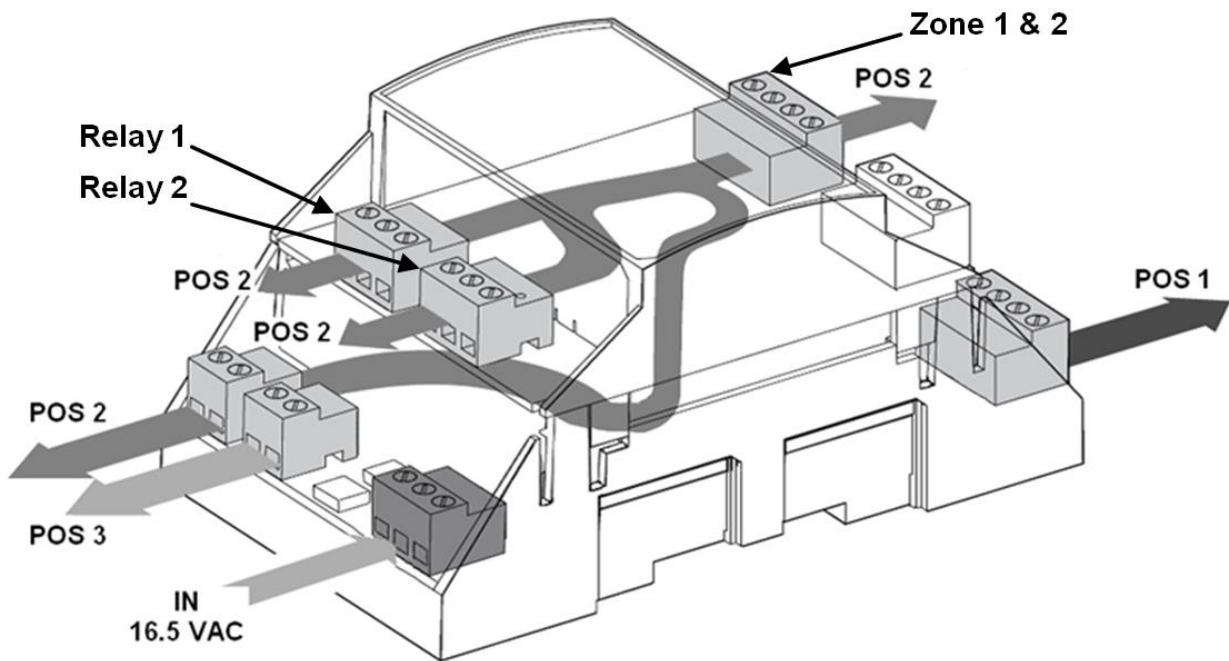

## Battery Connection

1. The smart power supply supports one or two battery configurations. If additional battery backup capacity is required, a second battery can be installed. Up to two 17.2 AH batteries can be connected to the unit.
2. Install batteries before connecting power.
3. Connect a single battery to the Battery 1 input.
4. If a second battery is required, connect it to the Battery 2 input.
5. Battery 2 becomes enabled once the battery test passes. A battery test will occur when power is connected to the smart power supply, daily battery test, or when a user manually activates a battery test. See keypad manual for instructions on performing a manual battery test.

## Connect Transformer and Tamper

1. A 16.5 VAC/40 VA transformer (recommended Interlogix PN 600-1023 or 600-1023-CN) must be utilized with the unit. Connect the transformer secondary voltage (16.5 – 18.0 VAC) to the smart power supply AC/DC IN connection.
2. If enclosure tamper monitoring is required, connect the tamper switch of the housing to the TAMPER input. You must enable tamper monitoring on the smart power supply in the device expander options menu (tamper monitoring is disabled by default).

## Over Current Protection

The smart power supply provides over current monitoring and protection. When more current is drawn from the power supply than the transformer can provide, the device will send an “Over Current” message to the Modular Hub CPU. The transformer is disconnected within 10 seconds of the over current condition event.

Operation continues on battery supply until the condition is removed, or batteries are exhausted.

## Auxiliary Current Table

Refer to table below to determine maximum available auxiliary current and battery capacity.

The UM-SPS has been designed to detect the number of batteries connected and provide the required charging current to fully recharge the batteries in 48 hours, per UL requirements. If two batteries are connected, there will be less current available for powering auxiliary devices. See the table below for specifications.

### 40VA Transformer

Number of Batteries	POS1 Current	POS2* Current	POS3 Current
1	500 mA	500 mA	500 mA
2	365 mA	365 mA	365 mA

---

**\*Note:** The POS2 Auxiliary current will be reduced based on utilization of the two onboard relays and current used by powered sensors connected to the two on board zone inputs.

---

## BUS Wiring and Topology

The UM-SPS smart power supply can be used as power supply unit or as a bus extension/isolator. Depending in which mode the unit is applied in the field, a different RS-485 LAN wiring is required.

In power supply mode (option 1), only the LAN connection terminal on the bottom board of the UM-SPS is used. Wire this terminal to the Modular Hub CPU.

See diagram [Wiring Option 1](#).

In bus extension/isolator mode (option 2), the CPU LAN +/- connections need to be wired to the ISOLATED LAN B +/- terminal on the top board of the UM-SPS. Any bus device wired to the LAN connection terminal on the bottom board is now optically isolated from the main CPU LAN +/- bus. See diagram [Wiring Option 2](#).

### Wiring Option 1 – Power supply mode, no bus isolation

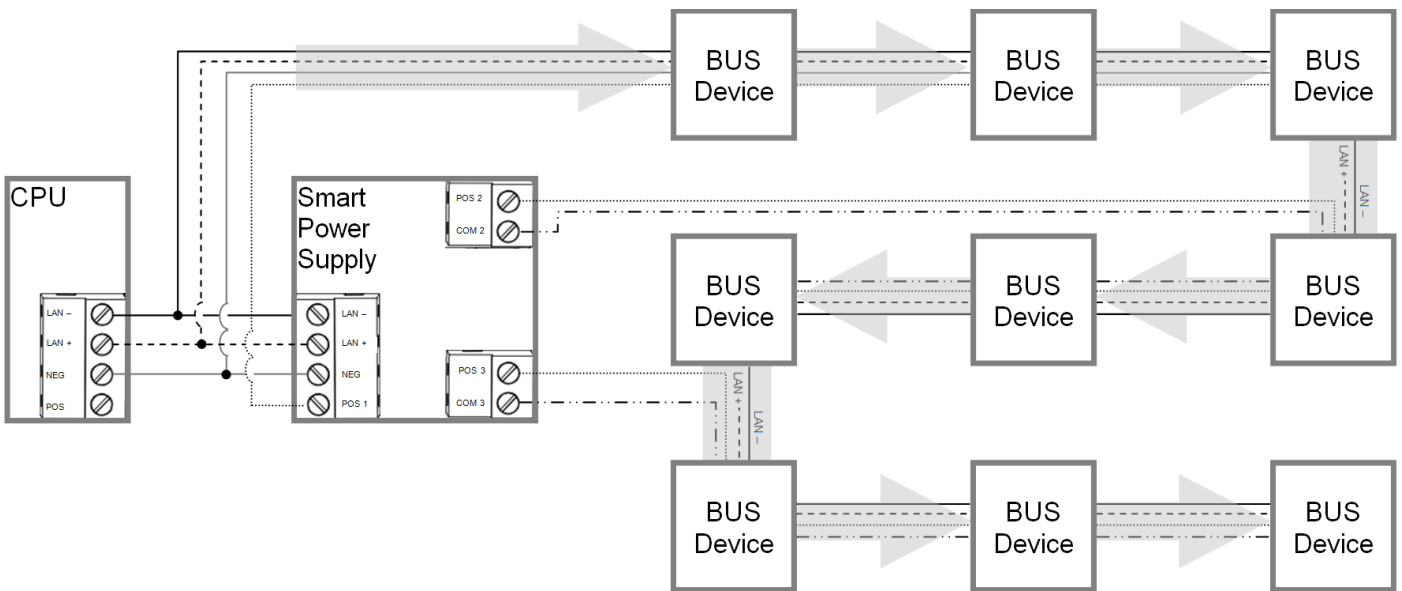

This option provides additional power to connect more devices.

1. Connect a 40 VA 16.5 VAC transformer to the smart power supply.
2. DO NOT connect CPU POS to the Smart Power Supply POS 1 terminal.
3. Connect the CPU NEG, LAN+ and LAN- to the UM-SPS smart power supply's NEG, LAN+ and LAN- terminal located on the bottom board. This provides data communication and a common ground.
4. Use POS1/NEG, COM2/POS2 and COM3/POS3 to power additional devices.
5. DO NOT use the ISOLATED LAN terminal located on the top board (POS B, NEG B, LAN B+, and LAN B-).
6. In this configuration, multiple smart power supplies can be cascaded to form a long daisy chain configuration.
7. It is recommended to utilize this configuration when multiple smart power supplies need to be cascaded to form a long daisy chain topology.

## Wiring Option 2 – Extension/isolator mode

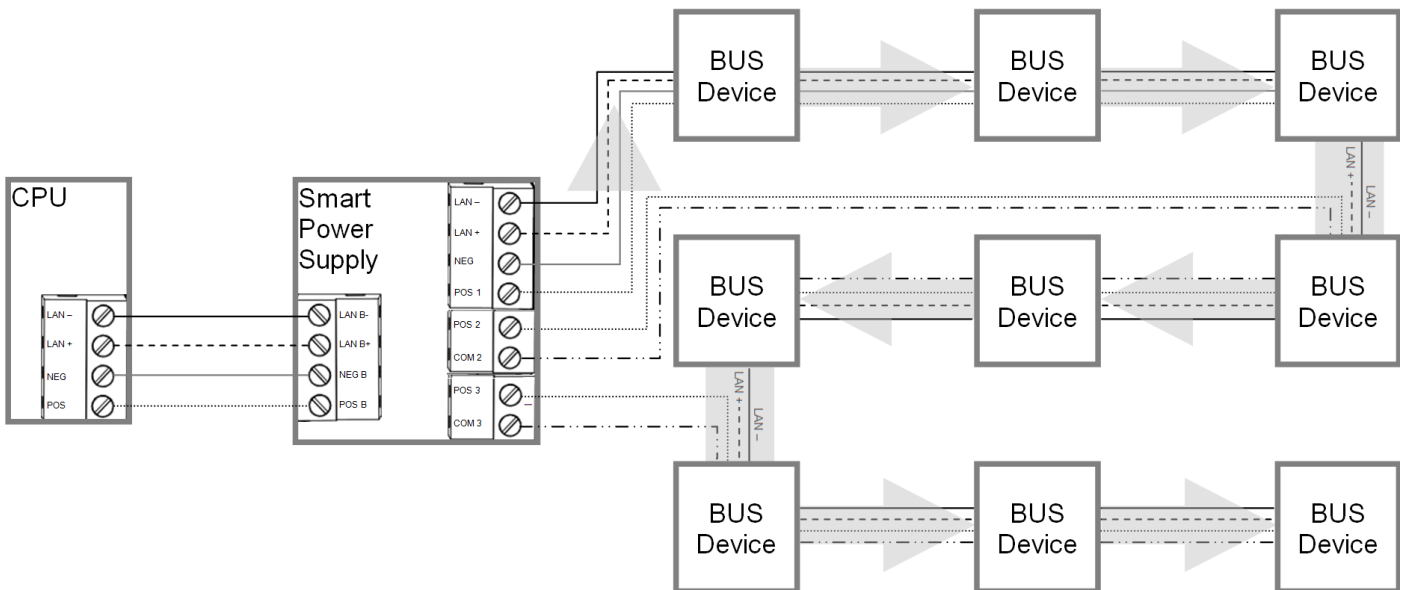

For larger sites requiring longer cable runs and/or more power, up to eight UM-SPS smart power supplies can be added.

This topology provides additional power and an optically isolated LAN bus between the Modular Hub CPU and each UM-SPS smart power supply. This is useful for connecting the bus between buildings which may require electrical isolation and/or optical isolation to avoid ground loops.

1. Connect the CPU terminals POS, NEG, LAN+ and LAN- to the Smart Power Supply ISOLATED LAN terminal POS B, NEG B, LAN B+, and LAN B-, located on the top board. The CPU will power the smart power supply's isolated LAN B+ and LAN B- terminals.
2. Do not connect the EARTH terminal on the Smart Power Supply to EARTH terminal on the CPU if you require electrical isolation. Follow the guidelines contained in Section 2.2 for connecting the [EARTH ground terminal](#).
3. Use POS1/NEG, COM2/POS2 and COM3/POS3 to power additional devices.
4. USE LAN + and LAN – to connect additional devices on the isolated bus.
5. In this configuration, multiple smart power supplies can NOT be cascaded to form a long daisy chain configuration.
6. It is recommended to utilize the optical isolation mode in most situations as it also isolates bus noise generated on one bus segment from transferring to other bus segments.
7. See below for typical topology in this configuration.



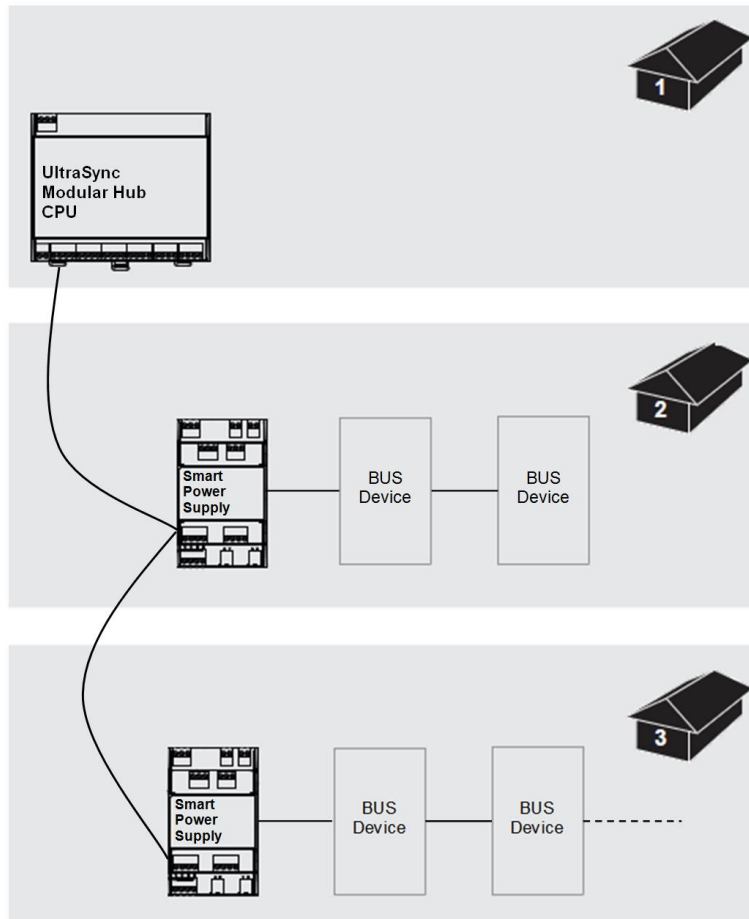

## Connect Relay Outputs

Two relay outputs are available on the smart power supply which can be programmed to activate when certain actions occur on the system. See how to program power supplies in Advanced Programming, System Devices [Section 6.9.1.5](#).

## Relay Modes

The two Single Pole Double Throw (SPDT) Form C relays can be configured in 3 different modes to support different applications.

The relays are connected to the output terminals with Normally Open and Normally Closed connections for your convenience.

Use the jumper next to the relay to select the mode suitable to your requirements.

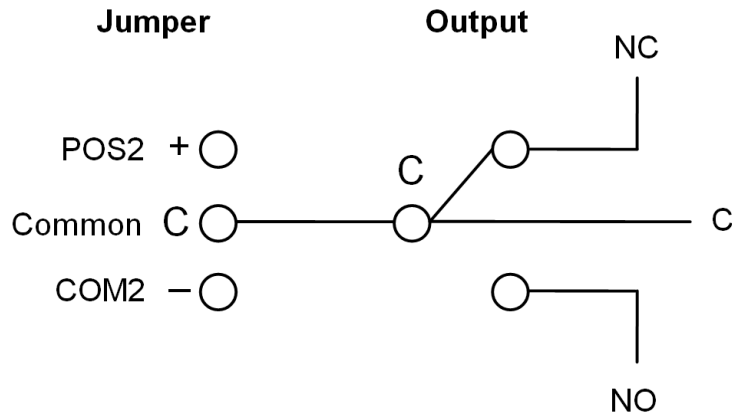

Default is no jumper with relay in NC position.  
Red LEDs light up when the respective relay is energized.

### No Jumper

Dry contact closure provided to output terminal.  
Maximum Load 30 VAC @ 0.5 A or 24 VDC @ 1 A.

### Jumper between C and COM2

Smart power supply common connection provided to output terminal @ typical 0 V. Do not exceed relay rating which is maximum load 30 VAC @ 0.5 A or 24 VDC @ 1 A.

### Jumper between POS2 and C

Smart power supply voltage provided to output terminal @ typical 12-13 VDC.  
Do not exceed relay rating.

## 1.10 Batteries

A lead acid rechargeable battery must be installed in the system to provide power in the event of main AC power failure. Several options are available as detailed in the table below. Select the appropriate battery based on your system configuration and required battery backup time. See specification [section S.4](#) for battery backup calculation details. Maximum battery capacity connected to the CPU is 12 Amp Hours.

CPU Battery Options	
Part Number	Capacity
60-681	4 Amp Hours
60-680	7 Amp Hours

Smart Power Battery Options	
Part Number	Capacity
60-681	4 Amp Hours
60-680	7 Amp Hours
60-781	17.2 Amp Hours

---

### Warning:

Make sure batteries are stored and worked on in a well ventilated area. ALWAYS wear approved safety glasses and face shield or splash proof goggles when working on or near batteries:

- Always wear proper eye, face and hand protection.
  - Keep all sparks, flames and cigarettes away from the battery.
  - Never try to open a battery with non-removable vents.
  - Make sure work area is well ventilated.
  - Exercise caution when working with metallic tools or conductors to prevent short circuits and sparks.
  - Always read and follow all precautionary labels on the product.
- 

## 1.11 Transformer

A 16.5 VAC transformer is used to power the system. Select the appropriate transformer from the options shown in the table below.

Transformer Options	
Part Number	Description
600-1023	Class 2 Transformer, 16.5V, 40VA
600-1023-CN	Class 2 Transformer, 16.5V, 40VA (Canada)



## 2 Hardware Installation

### Minimum System Requirements

CPU

Enclosure

Power Supply/Transformer

Keypad

Siren/Speaker

Battery

### Choose a Location

When choosing a location for the system components, there are a number of appliances and areas to avoid which could interfere with the system.

- Choose a location that optimizes signal strength (319.5, Z-Wave, Cellular)
- Avoid TV and other electronic appliances
- Avoid microwave ovens
- Avoid wet and moist areas such as bathrooms and kitchens
- Avoid cordless telephones
- Avoid computers and other wireless equipment
- Do not run bus wiring any closer than 6 inches to an AC or other communication lines.
- When crossing other lines, always run perpendicular

### 2.1 Power Requirements

The UltraSync Modular Hub is designed to be used with a 16.5 VAC transformer. Alternatively, an 18-26 VDC source can be utilized to power the system.

## 2.2 Grounding

The CPU's Earth terminal must be earth grounded for lightning protection to work effectively. The terminal should be tied to a verified cold water pipe or a dedicated, grounded copper rod 6' to 10' long. Use 16 gauge wire.

## 2.3 Shielding

If shielded cable is used, the shielding of all cables should only be connected on one end of the cable to one common grounding point in a building. If a shielded LAN cable is routed via more than one plastic device, the shielding from incoming and outgoing cables must be connected (e.g. multiple plastic enclosures that are daisy chained together).

## 2.4 Termination Jumpers

Correct RS-485 termination reduces communication issues with signal reflections.

For a single long cable run, put a jumper across the terminal labeled TERM on the CPU and the furthest bus device.

For installations with multiple long cable runs, (star configurations) do not place a terminator on the CPU; rather place one at the end of each of the two longest cable runs.

Where the keypad is the last bus device, use the terminal labeled S202.

## 2.5 Cable Requirements

The system's RS-485 communication bus is used to connect keypads and other devices to the CPU.

- 2 pair twisted, 22 AWG cable is recommended.

Minimum 4 twists per foot

Less than 16 pF per foot

Characteristic impedance of 100 to 120 ohms

The system's screw terminals support 30-16 AWG wire

The individual wires comprising the twisted pair must be connected to the LAN+ and LAN- terminals to receive the noise immunity benefits of twisted pair cable. See figure below. Do not combine the individual wires of the twisted pair to increase the effective wire gauge of the cable run.

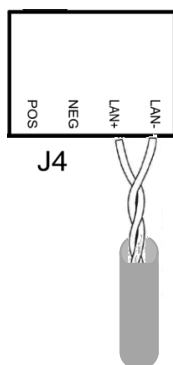

- Maximum RS-485 bus length is 2,600 ft. (800 m) when run as a single serial cable run. If a star configuration is utilized, the maximum total bus length may be reduced substantially depending on the number of branches, the length of the branches and a multitude of other factors. It is recommended to reduce the number of branches and the cable length when utilizing a star configuration.
- Device maximum: 64 bus devices.
- A separate power supply may be required for long cable runs with multiple devices due to voltage drop on the bus wire. If a device is powered with a separate power supply, do not connect “POS” from the CPU. Connect “+” of the local power supply to “POS” on the device, and connect 0 volts from the power supply and NEG from the CPU to the keypad terminal marked “NEG-”.

See [Appendix A.14](#) Calculating Maximum Bus Cable Length, for more details on determining when an additional power supply is required.

## 2.6 Ferrite Installation

Install the supplied ferrite on the Ethernet cable before attaching the cable to the intrusion panel.

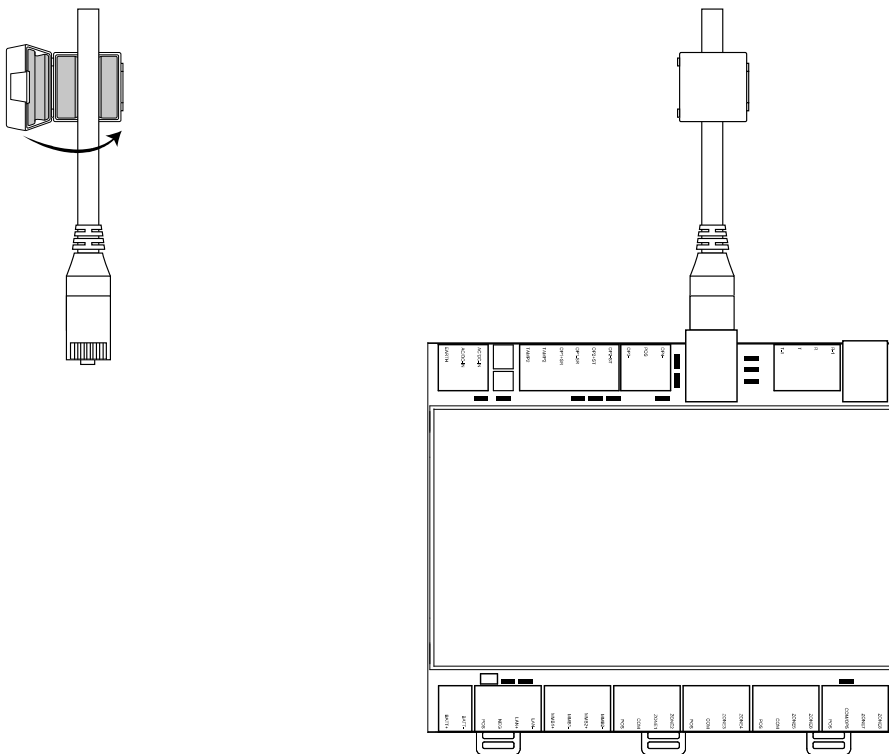

# 2.7 Wiring Diagram

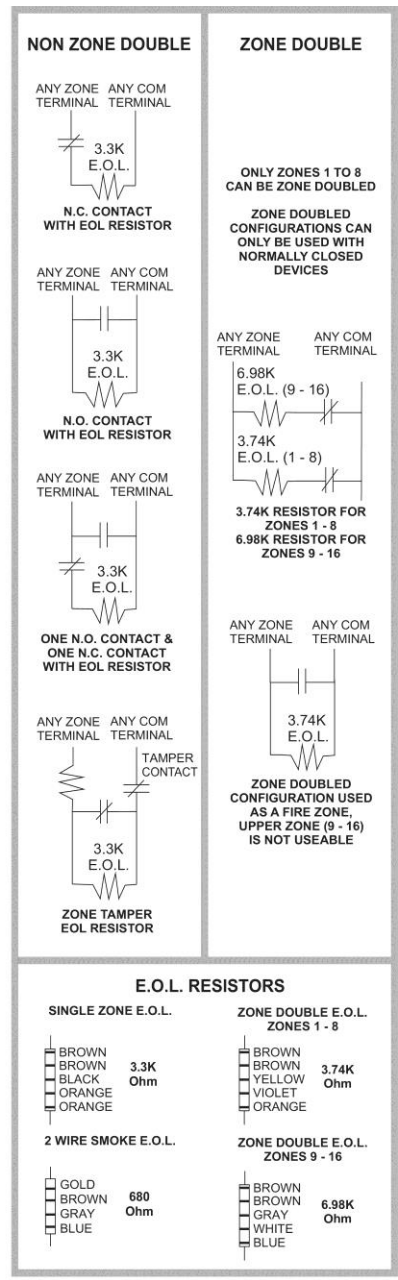
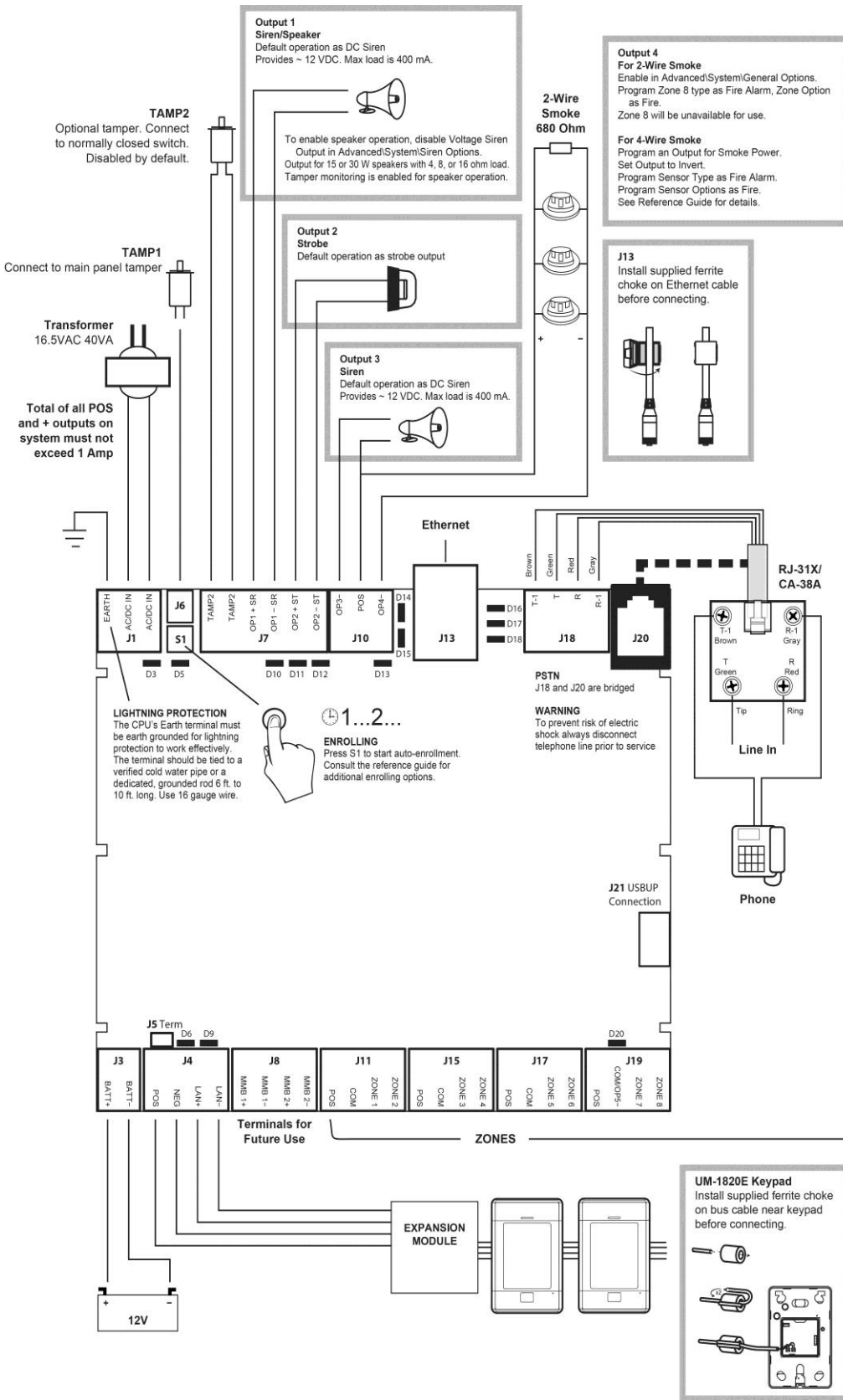



## 2.8 Terminal Diagram

- J1 – Terminals for power inputs
- J6 – Box Tamper (disabled by default)
- S1 – Enrollment button: Hold button down for 3s to activate automatic device enrollment feature; Holding the button down while powering up resets the Installer user type to a Master Installer user type.
- J7 – Terminals for Tamper 2 (disabled by default), Output 1 (Siren) and Output 2 (Strobe)
- J10 – Terminals for Output 3 (Siren) and Output 4 (2 and 4 wire smoke)
- J13 – RJ45 socket for Ethernet (IP/LAN) connection
- J18 – Terminals for telephone line, bridged to J20
- J20 – RJ11 6P4C socket for telephone line, bridged to J18 output. This connector is accessible after removing the plastic cover on the top of the CPU housing.
- J21 – 5-pin connector for USBUP device. This connector is accessible after removing the plastic cover on the side of the CPU housing. USBUP device can be used to update firmware or CPU configuration.

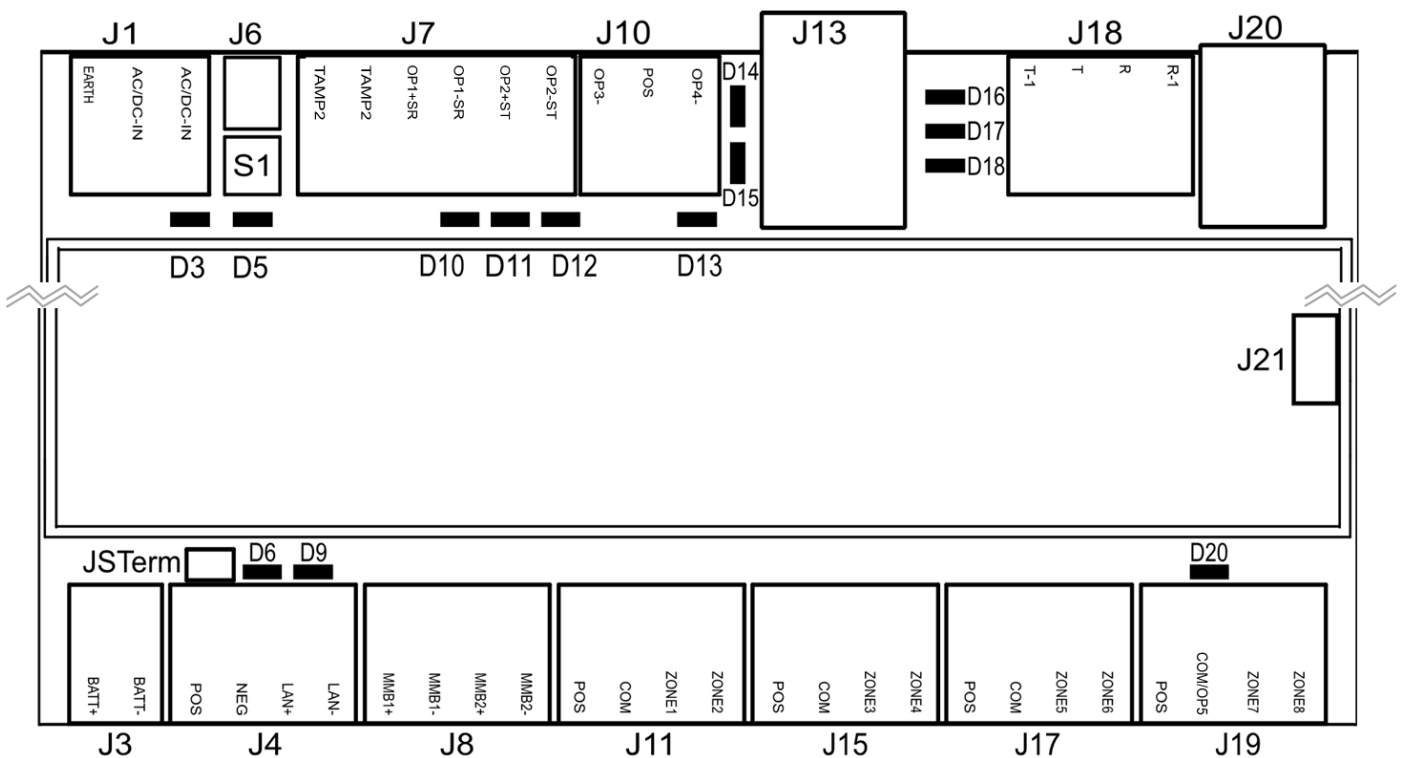

- J3 – Terminals for backup battery
- J4 – Terminals for RS-485 bus and auxiliary power connection
- J8 – Terminals for future use
- J11 – Terminals for Zone 1 and 2
- J15 – Terminals for Zone 3 and 4
- J17 – Terminals for Zone 5 and 6
- J19 – Terminals for Zone 7 and 8. Common terminal shared with output 5 (output 5 disabled by default)

## 2.9 LED Diagram

- D3 – Red LED: 5 V internal power present
- D5 – Red LED:
  - Enrollment mode active, slow flash means Automatic enrollment, fast flash means Manual enrollment
  - During a default it will toggle during each menu default
  - When communicating over the phone line it will turn on when a valid handshake tone or kiss off tone is present
  - During a phone session it will turn on when a DTMF digit is detected
- D10 – Red LED: follows Output 1 (BELL output), typically used for indoor speaker
- D11 – Red LED: follows Output 2 (Strobe)
- D12 – Red LED: follows Output 3 (Outdoor Siren)
- D13 – Red LED: follows Output 4 (Power)
- D14 – Red LED: Ethernet Link Present
- D15 – Green LED: Ethernet Activity
- D16 – Green LED: UltraSync Ethernet Link Present
- D17 – Green LED: UltraSync Cellular Link Present
- D18 – Red LED: Heartbeat, should flash every second

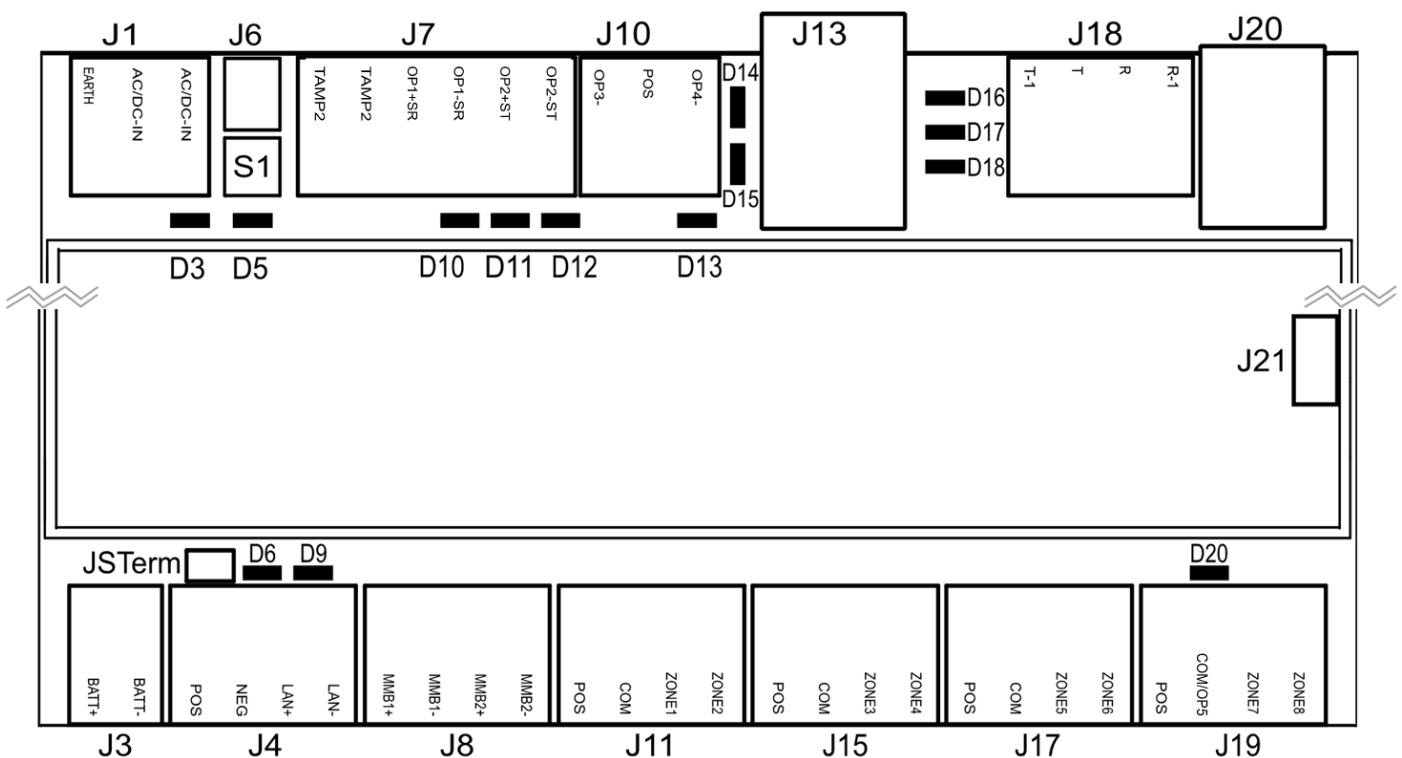

- D6 – Red LED: RS485 Transmitting
- D9 – Green LED: RS485 Receiving
- D20 – Red LED: follows Output 5 (Power)

## 3 Programming Methods

Once your hardware has been installed, there are four (4) ways to program your system.

- 1) Onboard Web Server
- 2) UltraSync Application
- 3) DLX 900
- 4) On-site keypad

Programming includes such tasks as enrolling bus devices, configuring the operation of the security system, adding IP cameras and Z-Wave devices.

It is required to first have a UM-1820E touchscreen keypad enrolled in the system before proceeding. Before any bus devices are connected to the CPU, connect a single UM-1820E to the bus and power up the system. To automatically enroll the keypad, push the ENROLL button on the CPU until the LED begins to flash indicating that the automatic enrollment process has been initiated.

**On Board Web Server** – The recommended method, this allows access to all programming menus from the built-in web server using a PC or smart device without the need to install any software. Local and remote access is supported. Remote access requires UltraSync Portal login credentials. Before you can utilize the local method, you will be required to retrieve the IP address of the CPU. Please see [Section 3.1.2](#) of this document for retrieving the IP address.

**UltraSync App** – This provides access to the Hub via a smart device running the UltraSync application. The screens and menus in the UltraSync application are similar to the Web Server screens. Before you can utilize the UltraSync App, you will have to enable this functionality in the CPU by programming the Web Access Passcode. This can be accomplished via the UM-1820E touch screen keypad or the on board web server. Please see [Section 3.2](#) for additional details.

**DLX 900 Upload/Download Management Software** – An alternative way to program your system from a PC. Before you can utilize DLX 900, you will have to enable this functionality in the CPU by programming the Download Access Code. This can be accomplished via the UM-1820E touch screen keypad or the on board web server. Please see [Section 3.3](#) for additional details.

**On-site Keypad** – The UM-1820E touchscreen offers a programming menu allowing full system configuration. Refer to the installation manual.

## 3.1 Programming via Web Server

This system has a built in web server which makes it easy and simple to set up your system from a web browser instead of the keypad.

Access to the Web Server is available locally when the computer or smart device is connected to the same LAN that the CPU is connected to. The Web Server is also available from remote locations when logged into the UltraSync portal.

### 3.1.1 Connect to LAN

The CPU is shipped to automatically receive its IP address from the local router. Simply connect the CPU to the local router via the Ethernet cable then turn on the power to your system. It will take approximately 10 seconds for the local router to assign the system an IP address.

### 3.1.2 Retrieve the CPU IP address

Retrieve the system's IP address via the keypad.

From the UM-1820E press:

**Menu – Program – ▼ – Communicator – IP Configuration – IP Address**

Write down the IP address of the CPU.

In the unlikely event that the router is not configured to automatically assign an IP Address, you will have to manually program an IP address for the system. Instructions to manually assign the network settings follows in section 3.1.3 below.

### 3.1.3 Manually Assign an IP Address

If you are unable to get an IP address from the router automatically, then your router may not be configured to automatically assign an IP address (via DHCP) or certain security settings may be enabled. Contact the router's network administrator for assistance and the assignment of the network settings for the CPU.

1. Turn DHCP off on the CPU.

On the keypad press:

**Menu – Program – ▼ – Communicator – IP Configuration – ▼ – ▼ – IP Options – Enable DHCP**. The display should show "N" to indicate that DHCP is disabled.

2. Manually assign network settings

- a. Press **Menu – Program – ▼ – Communicator – IP Configuration**

- b. Assign the following values that were provided by the network administrator:

1. IP Host Name (optional)
2. IP Address
3. Gateway
4. Subnet
5. Primary DNS
6. Secondary DNS (optional)

3. Connect your computer or smart device to the same router that the system is connected to. This connection to the router can be via Ethernet or Wi-Fi. Open your web browser on the device. If DHCP has been disabled in the router, you will have to manually assign an IP address/network settings to your computer or smart device. Consult with the network administrator if required.

### 3.1.4 Login to the Web Server

4. Enter the IP address of the CPU into a web browser. The login screen shown below should appear. Some browsers may require you to enter `http://` plus the system's IP address.

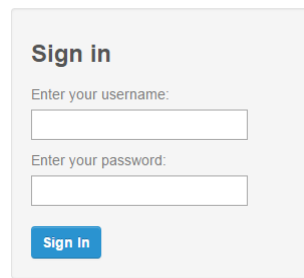

**Sign in**

Enter your username:

Enter your password:

**Sign In**

Enter your username and password. By default this is: **installer** and **9-7-1-3**. You should now see a screen similar to one of the below:

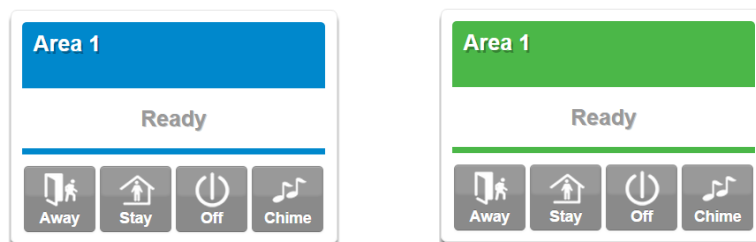

Your system is now successfully connected to your Ethernet network. Press **Settings** or **Advanced** to program your system.

### 3.1.5 Troubleshooting LAN Connections

- Check your router settings and try again.
- On the Touch Screen keypad press **Menu** – **[PIN]** – **[ENTER]** – **Program** – **Communicator** – **IP Configuration** – **IP Options**, this will allow you to modify connection settings including DHCP.
- If the panel is connected to a local router which provides internet access, open up a web browser on your computer or smart device and verify that you have internet access (make sure cellular service is disabled on cellular enabled devices such as tablets and smart phones when connecting over the LAN).

## 3.2 Programming via UltraSync

UltraSync is an app that allows cloud-based remote management and remote access to the system from an Apple® iPhone/iPad, or Google Android device.

Download the UltraSync app. Carrier charges may apply and an Apple iTunes or Google account is required.

### 3.2.1 Set Up a Web Access Passcode for UltraSync

For security, remote access via the UltraSync app is disabled by default. Follow these steps to enable it:

Select **Settings** - **Network** from the Web Server. Enable remote access for the UltraSync app by changing the Web Access Passcode (WAP). This is an eight digit code that permits access from the UltraSync application. The default Web Access Passcode of 00000000 prevents remote access.

Enter a Web Access Passcode.

**Settings Selector**

Network

Up Down Save

LAN configuration

IP Host Name

Enable DHCP

IP Address 

192	168	0	103
-----	-----	---	-----

Gateway 

192	168	0	1
-----	-----	---	---

Subnet 

255	255	255	0
-----	-----	-----	---

Primary DNS 

192	168	0	1
-----	-----	---	---

Secondary DNS 

0	0	0	0
---	---	---	---

Remote Access PINs

Web Access Passcode  ←

Download Access Code

Automation User Name

Automation PIN

Options

Enable Ping  ←

Enable UltraSync

Monitor LAN

Always Allow DLX900

Enable Web Program

Press **Save**.

Follow this sequence to program the Web Access Passcode using the keypad:

**Menu – PIN – Enter – Program – Network Servers – Web Access Passcode**

For a detailed explanation of the function of the Web Access Passcode please see Section 5.6, [Programming the Network](#).

### 3.2.2 Connect via UltraSync Application

On Apple® devices go to the App Store™. On Android devices go to the Google Play™ store.



Search for **UltraSync**.

Install the app.

Press the icon on your device to launch it.

Press + on the top right to add a new site, or the blue arrow to edit an existing site.

Enter the details of the security system.

The serial number is printed on the back of the panel. Alternatively login to the Web Server and go to Settings – Details to view it. You can also retrieve the serial number from

the keypad. On the Touch Screen keypad press **Menu – [PIN] – [ENTER] – Program – System – Status – Device Serial**.

The default username and PIN code for the installer is: installer and **9–7–1–3**. The default username and PIN code for User 1, the Master User is User 1 and **1–2–3–4**. You may also use any other valid user account. Users will only see and have access to menus at their permission level.

Press the **Done** button to save the details, then Sites to go back.  
Press the name of the Site; the app will now connect you to your system.

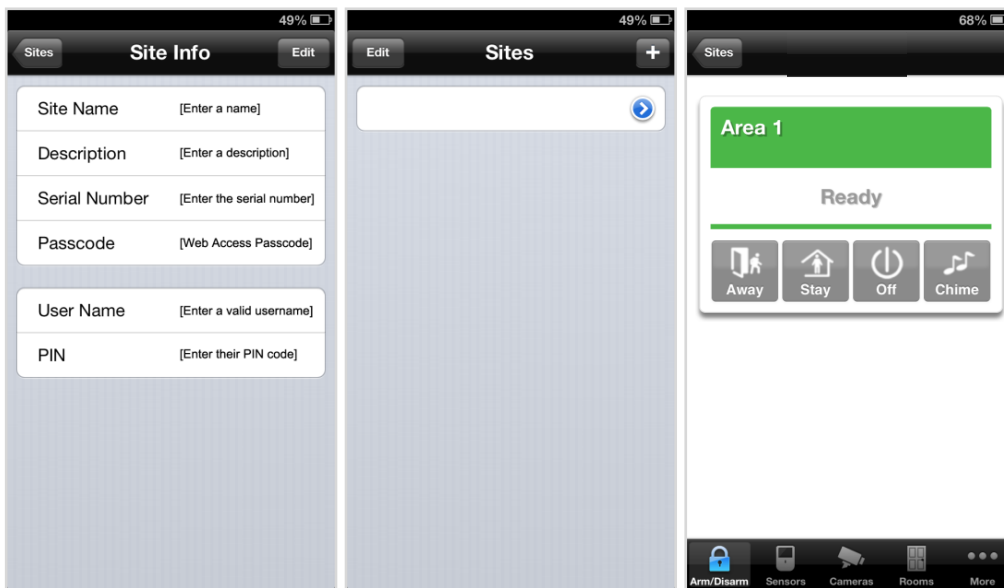

### 3.2.3 Check LAN Connection to UltraSync Servers

1. Login to the UltraSync Web Server as shown above
2. Click Settings
3. Select Connection Status in the drop down menu
4. Check:
  - LAN Status should display **Connected**.
  - UltraSync Status should display **Connected**.
  - UltraSync Media should display **LAN**.

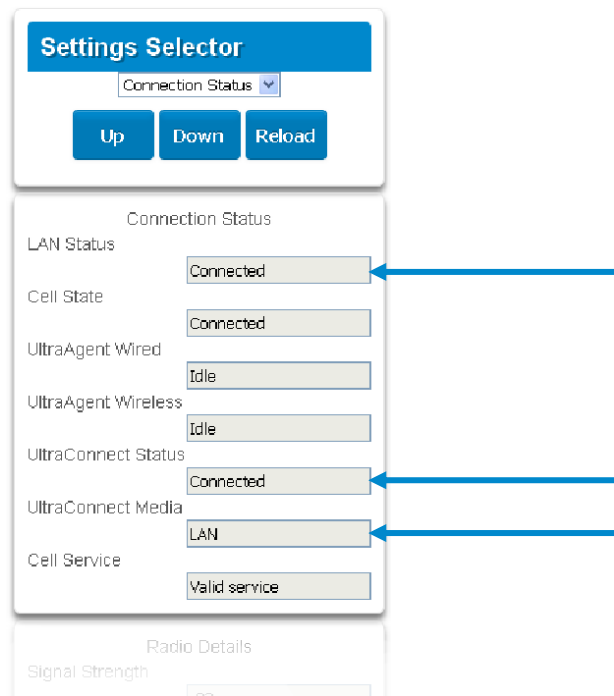

If it does not: Check cable connection and router settings.



## 3.2.4 Troubleshooting UltraSync Setup

1. UltraSync Site Creation fails	
Cause	Solution
Settings are entered incorrectly	Check the serial number, web access passcode, user name and PIN codes match those in the system.
	Web Access Passcode must not be 00000000.
	User Name must be entered with a space between the first and last name and with correct capitalization.
2. Cannot see local Wi Fi access point from smartphone	
Cause	Solution
Some hotspot access points may not accept 802.11g connections.	Ensure your Wi Fi access point is able to accept 802.11b or 802.11g.
3. Network connections fail	
Cause	Solution
Ethernet not working	If connected by Ethernet, check that the cable is plugged in and the connection is working.
Network not set	Check <a href="#">Settings – Network</a> – Enable UltraSync is checked.
4. Cannot get IP address	
Cause	Solution
The wireless/router may not be configured for automatic DHCP or certain security settings may be enabled.	Check with the router's network administrator and configure the system as required.
5. Cannot access internet	
Cause	Solution
Mobile device has no access	Open a web browser on your mobile device to double check access.
	Try disabling Wi Fi on your device once the system is configured and using the 3G/4G data connection of your device with the UltraSync app.
6. Server connections fail	
Cause	Solution
Server addresses are incorrect	Check the UltraSync servers are correct. See <a href="#">Advanced Programming, Network Servers</a> for reference.
	a. Ethernet Server 1 - zw1.UltraSync.com:443
	b. Ethernet Server 2 - zw1.zerowire.com:443
	c. Wireless Server 1 - zw1w.UltraSync.com:8081
	d. Wireless Server 2 - zw1w.zerowire.com:8081
7. Configuration setting changes fail	
Cause	Solution
Devices are not responding to inputs	Re-initialize equipment. Power cycle connected equipment including customer supplied router(s).

### 3.3 Programming via DLX 900 Management Software

Another method to manage your system is to use the DLX 900 up/download software. DLX 900 supports a variety of connection methods:

1. Connection over LAN (local)
2. Remote connection
3. Remote connection over dial-up PSTN

#### 3.3.1 Enable Remote Access for DLX 900

For security, remote access is disabled by default. Follow these steps to enable remote access for DLX 900:

Select **Settings - Network** from the Web Server. Enable remote access to the Hub by changing the Web Access Passcode (WAP). This is an eight digit code that permits remote access to the Hub. The default Web Access Passcode of 00000000 prevents remote access.

The Download Access Code enables remote access for DLX 900. Select **Settings - Network** from the Web Server. Enable remote DLX 900 access by changing Download Access Code. This is an eight digit code. The default Download Access Code of 00000000 prevents remote DLX 900 access.

#### 3.3.2 Connect using DLX 900 on LAN

1. Turn on power to your system
2. Connect an Ethernet cable from your laptop to the local router (or via Wi-Fi connection) and wait 10 seconds for the local router to assign an IP address.
3. On the keypad press **Menu – [PIN] – [ENTER] – Installer – Communicator – IP Configuration – IP Address** and note the IP address displayed.
4. Install DLX 900 on a suitable computer.
5. Start DLX 900
6. Create a new customer
7. Enter the IP address of your system in DLX 900
8. Click Save
9. Click Connect via TCP/IP
10. Click Read All

#### 3.3.3 Remotely Connect using DLX 900 on UltraSync

In order for DLX 900 to connect to a panel remotely, you will need to know the Download Access Passcode and the unit must be enabled to allow remote connections. Please see section 3.5.1.

1. Install DLX 900 on a suitable computer; refer to DLX 900 installation instructions.
2. Start DLX 900
3. Create a new customer
4. Enter the serial number, Download Access Passcode and Web Access Passcode of the system
5. Click Save
6. Click Connect via TCP/IP
7. Click Read All

### 3.4 Programming via On-Site Keypad

To Program the Web Access Passcode on the keypad press **Menu – [PIN] – [Enter] – Program – Network Servers – Web Access Passcode.**

Reserved: Future Content

### 3.5 Recommended Items to Change

**INSTALLER PIN** Always change this to prevent unauthorized access to the security system. Select Change PIN from the main menu to change the installer PIN.

Add your support contact information to the UM-1820E touchscreen keypad. When a user taps the SOS key then Installer, the Service Provider name and Contact number you enter will be displayed on the keypad. Program this information into each keypad by tapping "menu" then "settings" then "labels" then "Installer" to access this portion of the keypad programming.

**WEB ACCESS PASSCODE AND DOWNLOAD ACCESS CODE** These provide remote access to the UltraSync Web Server via the UltraSync app and DLX 900 management software.

Remote Access PINs

Web Access Passcode  
00000000

Download Access Code  
00000000

Automation User Name  
[Empty Field]

Automation PIN  
00000000



## 4 The UltraSync App



### 4.1 Install UltraSync App

UltraSync is an app that allows you to control your hub from an Apple® iPhone/iPad, or Google Android device. First set up the hub's Web Server then download this app. Carrier charges may apply and an Apple iTunes or Google account is required.

On Apple® devices go to the App Store™. On Android devices go to the Google Play™ store.



Search for **UltraSync**.

Install the app.

Press the icon on your device to launch it.

Press **+** on the top right to add a new site, or the blue arrow to edit an existing site.

Enter the details of your security system and choose the language you want to use.

The serial number is printed on the back of the panel. Alternatively login to UltraSync Web Server and go to Settings – Details to view it.

The default Web Access Passcode of 00000000 disables remote access. To change it, login to the hub's Web Server and go to Settings - Network.

The default username and PIN code is: **installer** and **9-7-1-3**, and **User 1** and **1-2-3-4**. You may also use any other valid user account. Users will only see and have access to menus at their permission level.

Press the **Done** button to save the details, then Sites to go back.

Press the name of the Site; the app will now connect you to your hub.

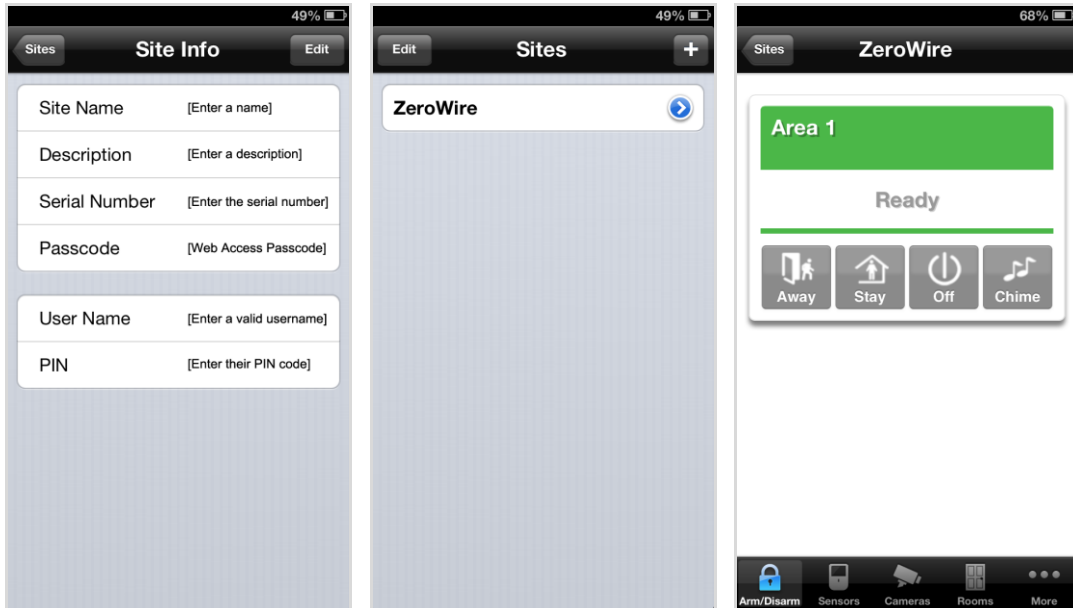

## 4.1 Using the App

The first screen that will appear once you connect is Arm/Disarm. This will display the status of your system and allows you to arm or disarm areas by pressing **Away**, **Stay**, or **Off**. From this screen you can also enable or disable Chime mode.

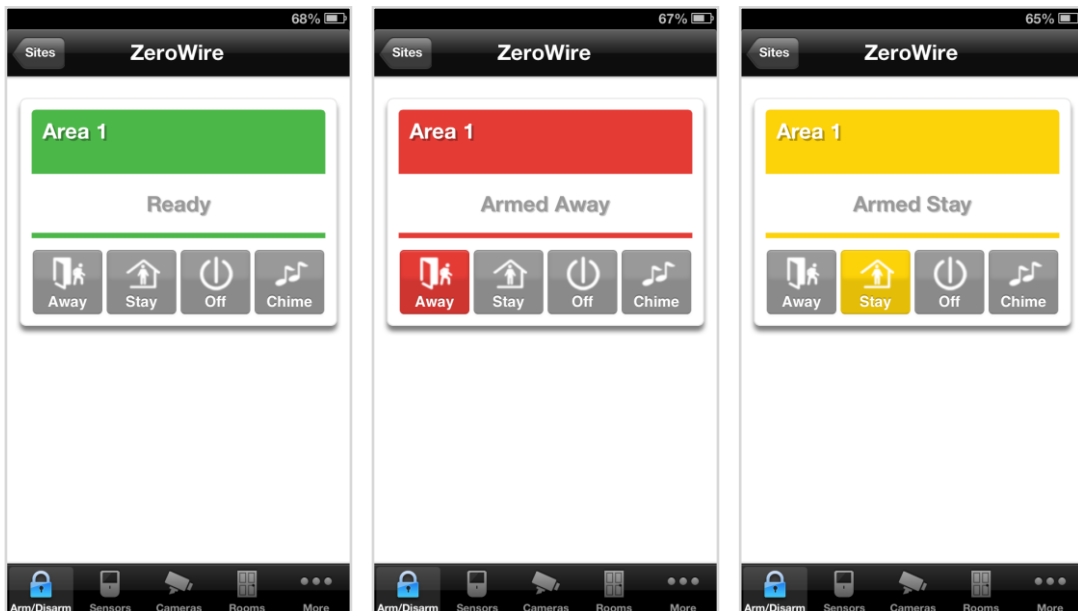

The menu bar is located along the bottom of the screen. Press **Sensors** to view sensor status. From the Sensors screen you can press **Bypass** to ignore a sensor or press it again to restore it to normal operation. You may also add or remove a sensor from the Chime feature.



Press  to view any cameras connected to the system.

This is a live view of the camera.

Press  to view the last recorded clip by that camera.

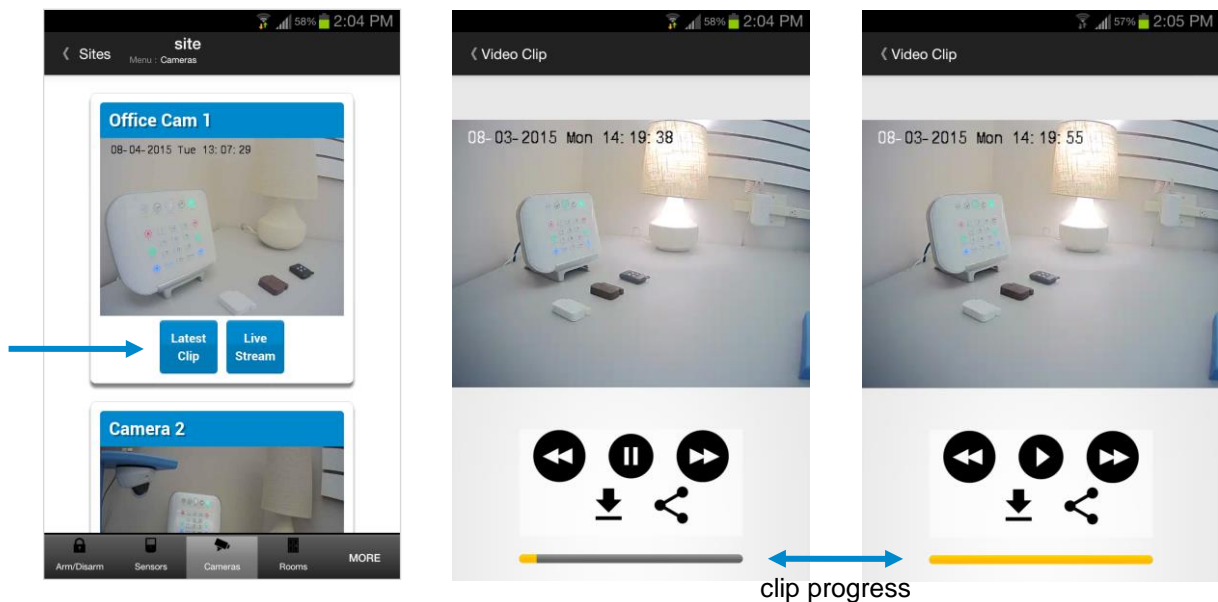

You can also access video clips linked to History events.

Press  from the History screen.

Master users will have access to the full Users menu for creating and managing users.

See Section 7, [Users and Permissions](#) for definitions of user levels and permissions.

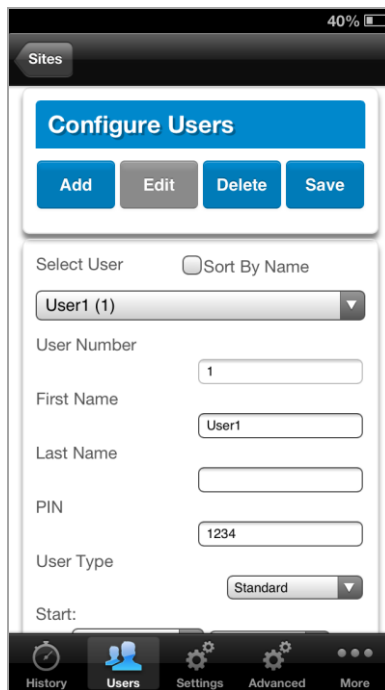

When you login with the Installer account you will also have access to additional menus for setting up and programming the system.

Installer menu, Settings

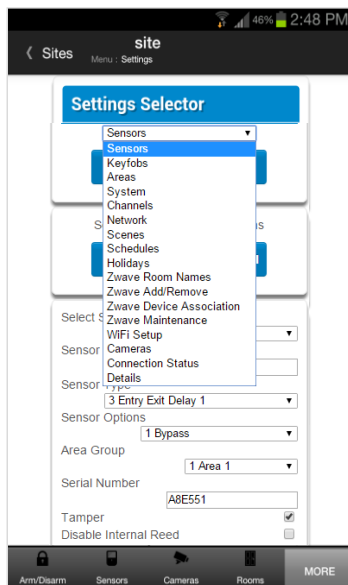

Installer menu, Advanced

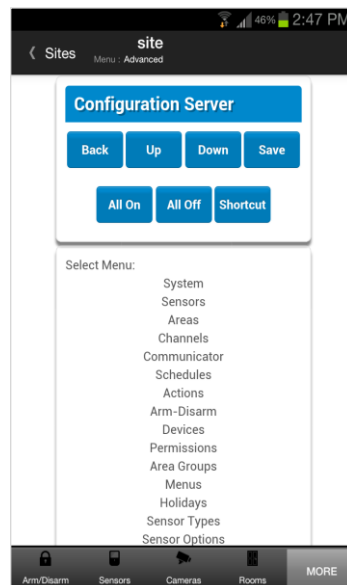



## 4.2 UltraSync Color Codes

UltraSync's display tiles are color coded for easy recognition.

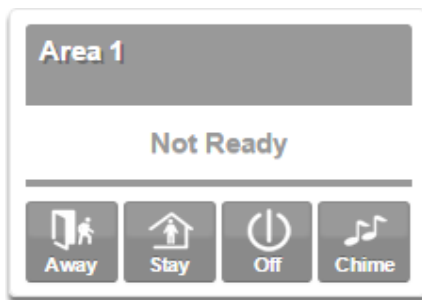

Not Ready

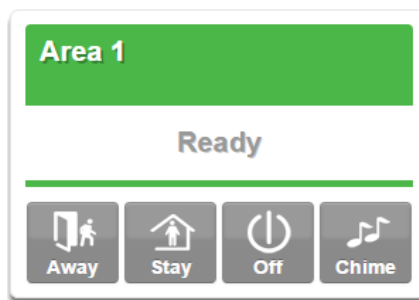

Ready

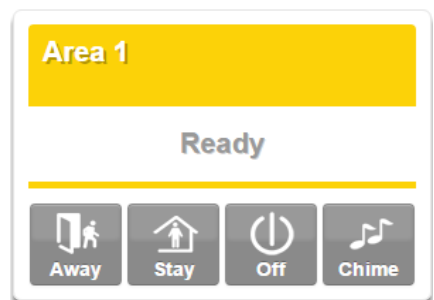

Ready with at least 1 sensor bypassed

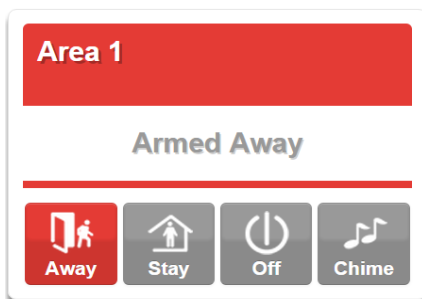

Armed, Away

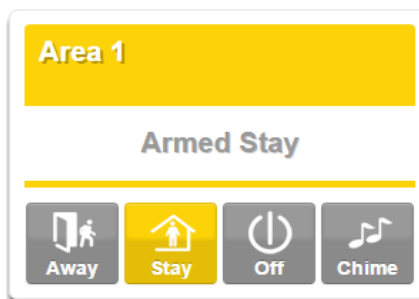

Armed, Stay

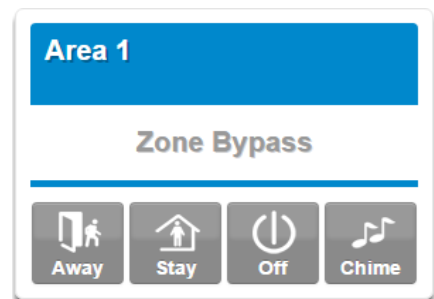

Message, Error



## 5 System Settings

These instructions describe how to program the system. The description and screenshots depicted below show the procedure utilizing the Web Server. Utilizing the UltraSync app is virtually identical.

### 5.1 Learn in Sensors

Connect to the system (either via [Web Server Configuration](#), or the [UltraSync](#) app).

Enter your username and password. By default this is **installer** and **9-7-1-3**. Press **Sign In**.

You should see a screen similar to one of the below:

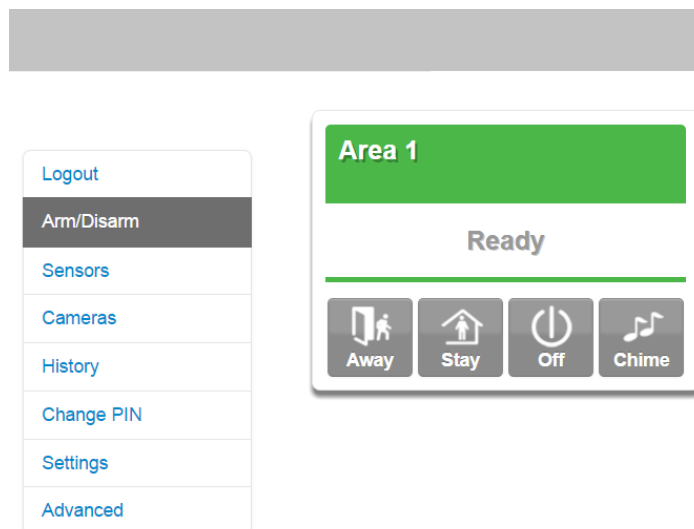

Click on the Settings bar, and then select **Sensors** from the menu to see the list of programmable items.

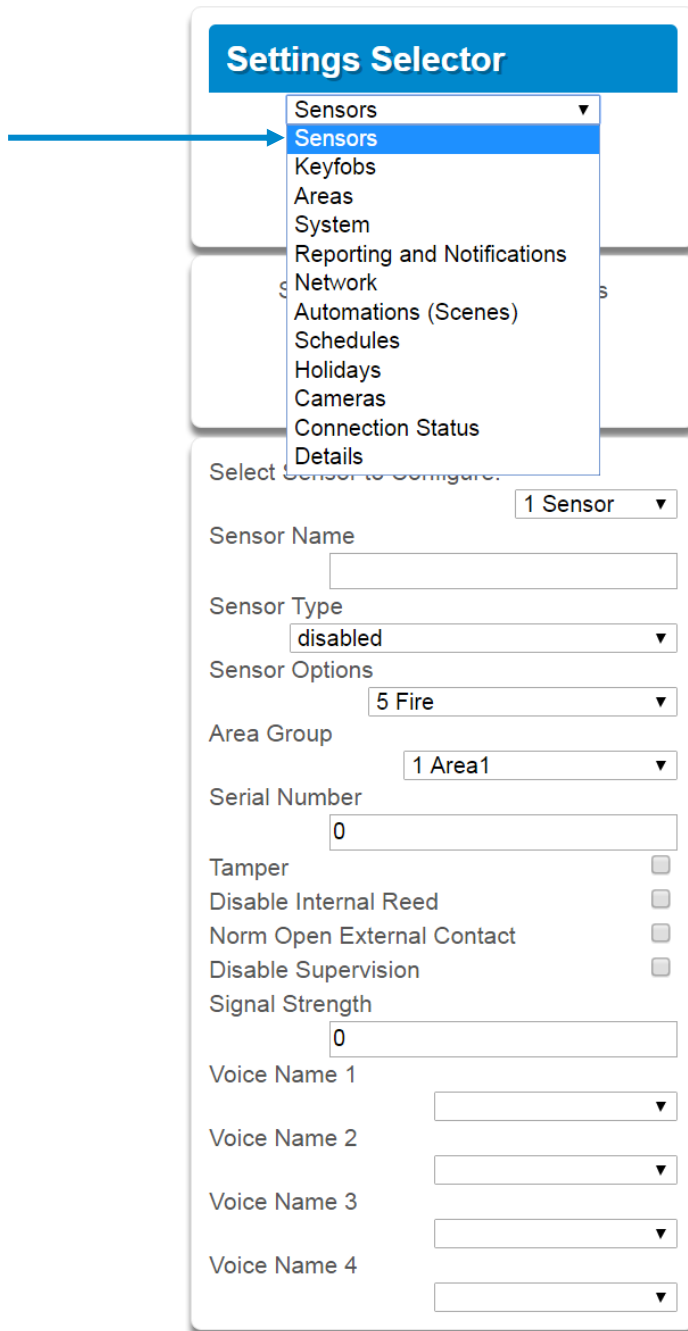

At this point you can type the name of the sensor and define its profile, by determining the sensor type (Entry, 24 hour, fire, key switch, etc.) and the sensor options (bypass, force arm, Cross Zone, stay mode, etc.). You can also assign it a specific area. Each of these has a drop down menu to make selections.

## Sensor Type

Select Sensor to Configure: 1 Sensor ▼

Sensor Name

Sensor Type

Sensor Options

Area Group

Serial Number

Tamper

Disable

Norm Open Ext

Disable Superv

Voice Name 1

Voice Name 2

Voice Name 3

Voice Name 4

3 Entry Exit Delay 1

disabled

1 Day Zone

2 24 Hour Audible

3 Entry Exit Delay 1

4 Entry Exit Delay 2

5 Follower

6 Instant

7 24 Hour silent

8 Fire Alarm

9 Entry Exit Delay 1 Auto-Bypass

10 Entry Exit Delay 2 Auto-Bypass

11 Instant Auto-Bypass

12 Event Only

13 Momentary Key Switch

14 Latching Key Switch

15 CO Detector

16 Sensor Type

17 Sensor Type

18 Sensor Type

19 Sensor Type

## Sensor Options

Select Sensor to Configure: 1 Sensor ▼

Sensor Name

Sensor Type

Sensor Options

Area Group

Serial Number

Tamper

Disable Intern

Norm Open Ext

Disable Superv

Voice Name 1

Voice Name 2

Voice Name 3

Voice Name 4

3 Entry Exit Delay 1

disabled

1 Bypass

2 Bypass Stay

3 Bypass - Forced Arm

4 Bypass - Cross Zone

5 Fire

6 Panic

7 Silent Panic

8 Normally Open no EOL

9 Normally Closed no EOL

10 Gas Detected

11 High Temp

12 Water Leakage

13 Low Temp

14 High Temp

15 Fire Alarm Pull Station

16 Night Mode

17 Sensor Options

18 Sensor Options

19 Sensor Options

## Sensor Area Group

Select Sensor to Configure: 1 Sensor ▼

Sensor Name

Sensor Type

Sensor Options

Area Group

Serial Number

Tamper

Disable Internal Reed

Norm Open External Co

Disable Supervision

Voice Name 1

Voice Name 2

Voice Name 3

Voice Name 4

3 Entry Exit Delay 1

1 Bypass

1 Area 1

disabled

1 Area 1

2 Area 2

3 Area 3

4 Area 4

5 Area 1, 2

6 Area 1, 3

7 Area 1, 4

8 Area 2, 3

9 Area 2, 4

10 Area 3, 4

11 Area 1, 2, 3

12 Area 1, 2, 3, 4

13 Area Group

14 Area Group

15 Area Group

16 Area Group

When all of your programming definition for the sensor is complete, press **Learn** if this is a wireless sensor. A notification box will appear below the learn button. Activate the sensor. Consult the sensor manual for instructions; generally this is performed by opening the case and manipulating the tamper activator. This will send a tamper signal. The notification box will alert you that a new device was found.

**Settings Selector**

Sensors ▼

Up Down Save

Sensor Add/Remove Functions

Learn Remove Cancel

Learn Mode Active  
Activate Learn Button

**Settings Selector**

Sensors ▼

Up Down Save

Sensor Add/Remove Functions

Learn Remove Cancel

New Device Found.  
Click Save to Store New Device

The screen below shows a sensor learned in.

Name: Front Door  
Type: Entry Exit Delay 1  
Option: Bypass  
Area Group: Area 1  
Serial Number: A8E551

**Note:** The sensor's Serial Number field is populated after learning in the sensor.

**Settings Selector**

Sensors

Save

Sensor Add/Remove Functions

Learn Cancel

Select Sensor to Configure:

1 Sensor

Sensor Name

Sensor Type

3 Entry Exit Delay 1

Sensor Options

1 Bypass

Area Group

1 Area 1

Serial Number

A8E551

Tamper

Disable Internal Reed

Norm Open External Contact

Disable Supervision

Voice Name 1

FRONT

Voice Name 2

DOOR

Voice Name 3

SENSOR

Voice Name 4

ONE

Explanations of the sensor configurations appear on the next page.

Also reference [Advanced Programming, Sensors](#), Section 6.

Sensor Configuration Menu	Option	Default	Function
	Select Sensor to Configure	1 Sensor	Choose among 64 sensors.
	Sensor Name	Blank	Custom 32 character name
	Sensor Type	3 Entry Exit Delay 1	Sensor types determine the sensor attributes such as entry/exit, instant, etc. Additionally sensor types determine the siren attributes.
	Sensor Option	1 Bypass	Sensor options determine the sensor attributes such as a sensor's ability to be bypassed, force arm, Cross Zone, stay mode, etc. Additionally sensor options determine the sensors reporting attributes.
	Area Group	1 Area 1	Assigning a sensor to an area will enable it to report.
	Serial Number	Blank	This is the TXID of the wireless sensor, it can be manual entered or the sensor can be "Learned" into panel.
	Tamper	On	Tamper switch on the wireless sensor is enabled or disabled.
	Disable Internal Reed	Off	The internal reed switch(es) on the wireless device can be disabled. Applies if the sensor is a device type 10.
	Norm Open External Contact	Off	The external input on wireless sensors can be enabled. Check this box when external contact is normally open. If the 60-362N-10-319.5 sensor is used the jumper pin does not have to be used. Applies if the sensor is a device type 10.
	Disable Supervision (Wireless Sensors)	Off	At default the hub monitors its connections to wireless sensors, which broadcast supervisory packets to the panel. Disabling supervision makes the hub unresponsive to supervisory packets sent from that sensor. Typically used for mobile sensors such as wrist panic devices.
	Voice Name 1	Blank	This feature uses the internal voice vocabulary to name the sensor. These names will be announced in sequence when the sensor is opened while in the Chime mode.
Voice Name 2	Blank		
Voice Name 3	Blank		
Voice Name 4	Blank		

These dialogue boxes appear after any changes to the system are attempted/registered.

When you are finished programming the Sensor,

Press the **Save** button.  
 A dialogue box appears.  
 Press the **OK** button.  
 A dialogue box appears.  
 Press the **OK** button.

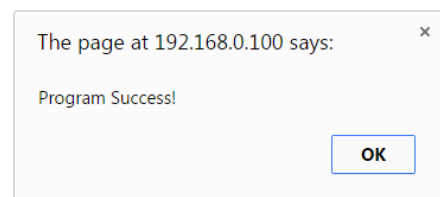
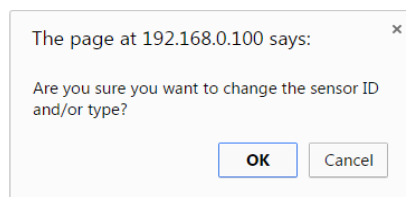

**Note:** After you have finished programming a sensor, be sure to advance the sensor number in the drop down menu when programming the next sensor. Otherwise you will over-write the sensor configuration you just programmed.

## 5.2 Learn in a Keyfob

Click on the Settings bar, and then select **Keyfobs** from the menu to see the list of programmable items.

With the keyfobs screen selected you can choose the keyfob number to configure and select the user number to link to the keyfob.

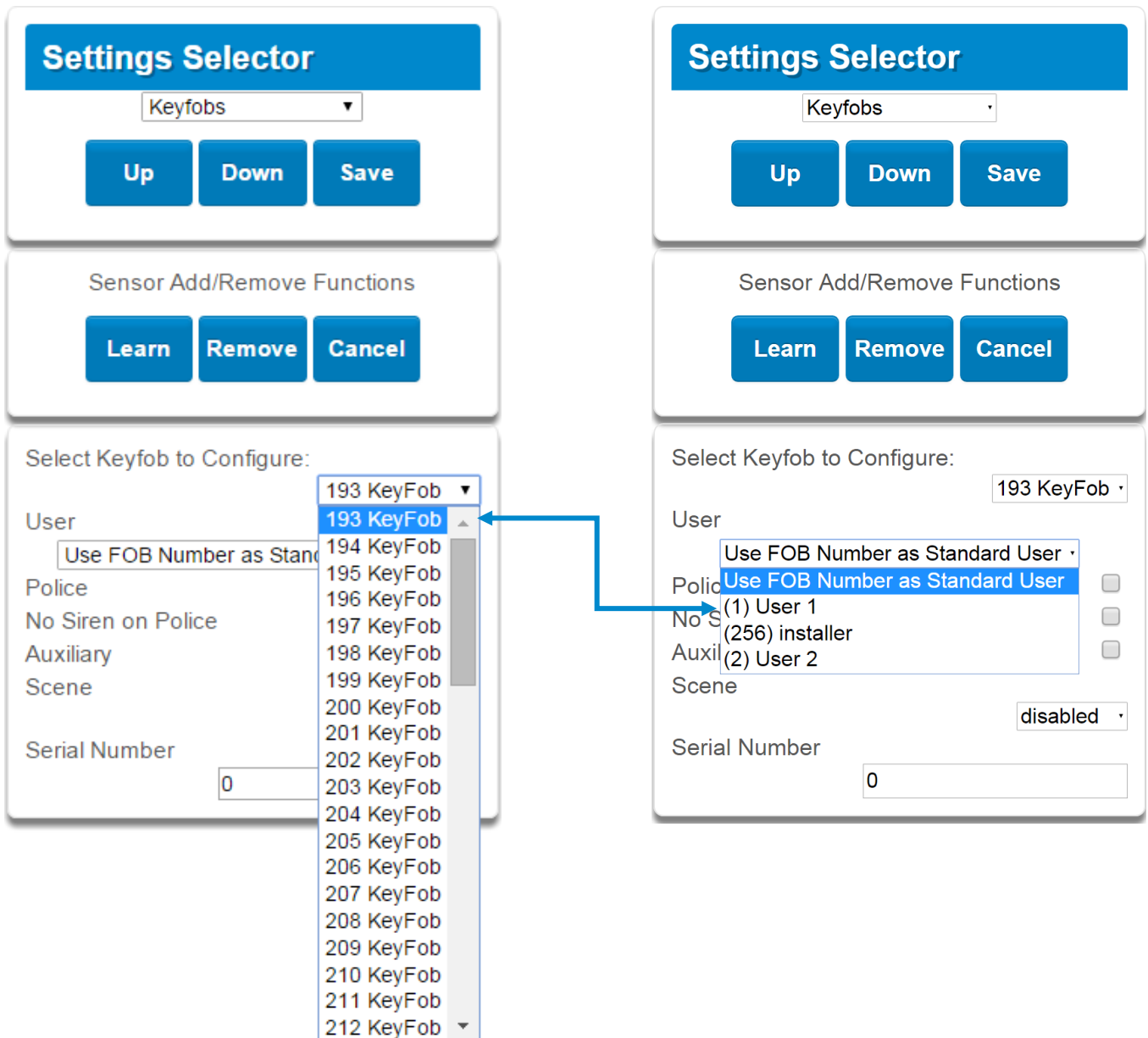

Give the keyfob a number (you are giving the keyfob a sensor number). Select the user and press **Learn**. A notification box will appear below the learn button. Activate the keyfob. Consult the keyfob manual for instructions; this is performed by simultaneously pressing the lock and unlock buttons. This will send a tamper signal.



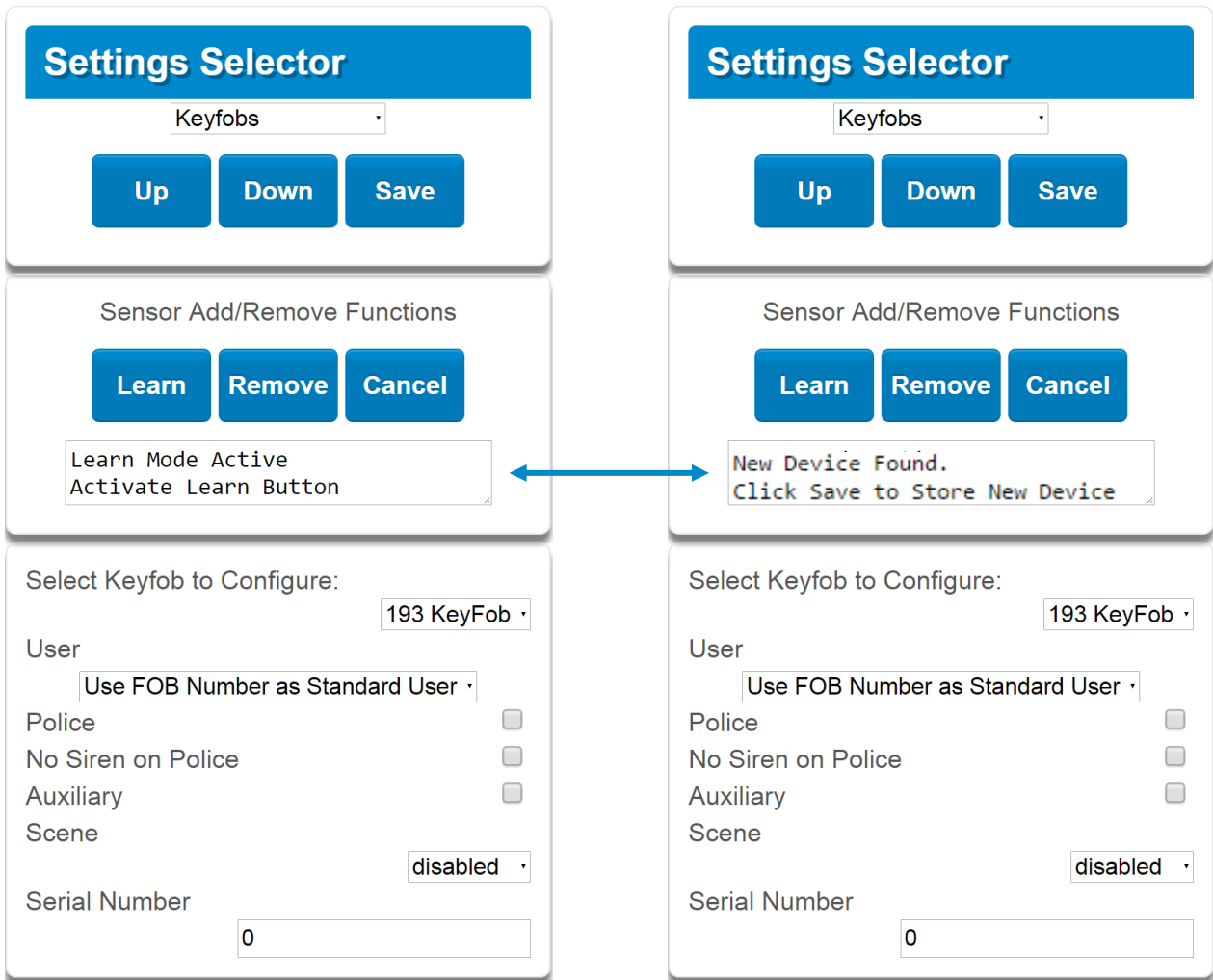

The notification box will alert you that a new device (keyfob) was found. The keyfob Serial Number box will be populated. Explanations of the Keyfob configurations appear on the next page.

	Option	Default	Function
Keyfob Configuration Menu	Select Keyfob to Configure	193 Keyfob	This is the starting Sensor number for Keyfobs.
	User	Use FOB Number as Standard User	If "Use FOB Number as Standard User" is used, when there is an activation on that Fob the Central Station report will come in with that sensor number. If there is a user assigned to the fob that user number will come in on the Central Station Report. If no user is assigned it will show as user 999 in the Central Station Report.
	Police	Off	Enabling this will enable the Police / Panic on the Fob, this will also be audible at the panel (top 2 buttons press at the same time).
	No Siren on Police	Off	With this enabled it will make the Police / Panic silent at the panel.
	Auxiliary	Off	Enabling this will enable the Medical / Aux on the Fob. This will be an audible alarm at the panel. (bottom 2 buttons pressed at the same time)
	Scene	Off	By using the drop down menu one of 16 scenes can be activated.
	Serial Number	Blank	This is the TXID of the Fob, it can be manually entered or the sensor can be "Learned" into panel.

When you are finished programming the Keyfob,

Press the **Save** button.  
 A dialogue box appears.  
 Press the **OK** button.  
 A dialogue box appears.  
 Press the **OK** button.

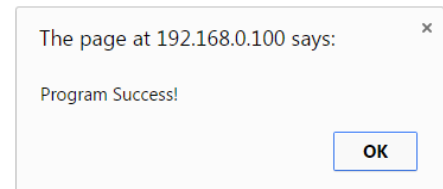
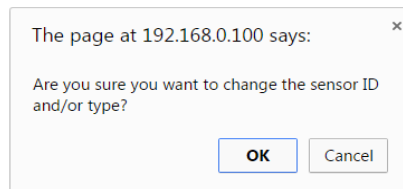

These dialogue boxes appear after any changes to the system are attempted/registered.

## 5.3 Programming Areas

Click on the Settings bar, and then select **Areas** from the drop down menu to see the list of programmable items.

With the Areas screen selected you can choose an Area number to configure, give the area a name, and define attributes for that area.

The system can support a total of 4 areas; each area is configured with its entry and exit times, area options, area timers, area type and reporting characteristics.

The screenshot shows a vertical stack of configuration panels for an area. At the top is a blue header 'Settings Selector' with a dropdown menu set to 'Areas' and a blue 'Save' button. Below this is a section 'Select Area to Configure:' with a dropdown menu set to '1 Area' and an empty 'Area Name' text box. The next section is 'Area Timers' with five input fields: 'Entry Time 1 [30-240] Seconds' (30), 'Exit Time 1 [45-255] Seconds' (60), 'Entry Time 2 [30-240] Seconds' (60), 'Exit Time 2 [45-255] Seconds' (60), and 'Stay Entry Time [30-240] Seconds' (30). The 'Area Options' section contains six items with checkboxes: 'Quick Arm Away (No PIN)' (unchecked), 'Quick Disarm - Stay Mode' (unchecked), 'Manual Panic' (checked), 'Manual Panic is Silent' (unchecked), 'Manual Fire' (checked), and 'Manual Auxiliary' (checked). The final section is 'Area Reporting' with 'Force Arm With Bypass' (unchecked), 'Area Account' (0), and 'Area Channels' (1 Channel Group).

Explanations of the Area configurations appear on the following pages. Also reference [Advanced Programming, Areas](#), Section 6.3.

Note: When programming Areas 2 and above, a value of 0 for any Area Timer forces the system to utilize the Area 1 settings for the timer value. Also, a selection of “disabled” for the Area Channels option forces the system to utilize the Area 1 setting for the Area Channels.

# Areas Configuration Menu

	Option	Default	Function
	Select Area to Configure	Area 1	Use the drop down menu to select which of the 4 areas to program.
	Area Name	Blank	Each area can be configured with a custom 32 character name. The area name is displayed wherever an area is referenced on the system.
Area Timers	Entry Time 1 (30-240) Seconds	30	Provides time to enter into the premises to deactivate the alarm system.
	Exit Time 1 (45 - 255) Seconds	60	Provides time to exit the premise without activating the alarm system.
	Entry Time 2 (30 - 240) Seconds	30	If there is a second entry door that requires more time to deactivate the alarm system.
	Exit Timer 2 (45 -255) Seconds	60	If there is a second exit door that requires more time to leave.
	Stay Enter Timer (30 - 240) Seconds	30	When the system is armed to "STAY" this will be the entry time to deactivate the alarm system.
Area Options	Quick Arm Away (No PIN)	Off	If enabled, the area can be armed in away mode with a single press. When area is armed via quick away mode, the closing user number is the default user of 999.
	Quick Disarm - Stay Mode	Off	If enabled, this will allow the stay mode to be disarmed by pressing the stay key on the keypad. If the system is in alarm a PIN must be used.
	Manual Panic	On	Enables or Disables the Keypad Panic
	Manual Fire	On	Enables or Disables the Keypad Fire
	Manual Auxiliary	On	Enables or Disables the Keypad Auxiliary
	Force Arm With Bypass	Off	<p>If enabled, the area can be armed even if sensors are not ready. Any sensors that are not ready will NOT be automatically be bypassed and may cause an alarm condition because they could still be in a not ready state once the area becomes armed.</p> <p>This option is overridden if the Force Arm With Auto-Bypass is enabled.</p> <p>Individual sensors can be made "force arm-able without auto-bypass" by leaving this area option off, then enabling Forced Arm Enable in Sensor options, and disabling Sensor Inhibit (Bypass) in the Sensor Type Profile.</p>

Areas Configuration Menu	Area Reporting	Area Account	0	This account number is ONLY used when sending an email. This should be the same as the Central Station account number, however if it is not this will not affect the Central Station reporting
		Area Channels	1 Channel Group	This determines which channel will be used to report area events to the Central Station. The channel must be configured in the Channel option programming.

When you are finished programming the Area settings, remember to save your changes.

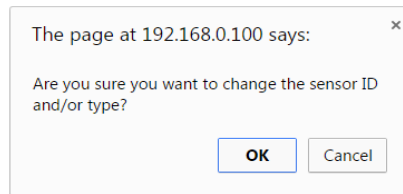

## 5.4 Programming the System

Click on the Settings bar, and then select **System** from the drop down menu to see the list of programmable items.

When the System screen is selected you can program several system wide settings, including the system clock and timers, as well as sensor options and reporting.

The screenshot displays the 'Settings Selector' interface for the 'System' control. It is organized into several sections:

- Settings Selector:** A blue header with a dropdown menu set to 'System' and three buttons: 'Up', 'Down', and 'Save'.
- Control Name:** A text input field containing 'Alarm System'.
- Language:** A dropdown menu set to 'English'.
- Voice Language:** A dropdown menu set to 'English'.
- System Date and Time:** A section with 'Date:' set to '04 / 17 / 2066' and 'Time (hh:mm:ss):' set to '8 36 12'.
- System Time Zone:** A section with 'Hours Offset' set to 'UTC-5 ET' and 'Minutes Offset' set to '0'.
- System Daylight Saving Time:** A section with 'Start Month' (Mar), 'Start Week' (Second), 'End Month' (Nov), and 'End Week' (First).
- System Timers:** A section with various timer settings:
  - Siren Time [0-99] Minutes: 3
  - Battery Test Time [0-99] Minutes: 0
  - Battery Missing Time [0-65] Seconds: 0
  - AC Failure Report Delay [0-999] Seconds: 600
  - Cross Zone Time [30-999] Seconds: 60
  - Sensor Inactivity Time [0-65535] Minutes: 0
  - Fire Supervise Time [120-65535] Seconds: 14400
  - Burg Supervise Time [120-65535] Seconds: 28800
- System Options:** A section with five checkboxes, all of which are currently unchecked:
  - Panel Zone Doubling
  - Panel Box Tamper
  - System Sensor Tamper
  - Disable Hardwired Sensors
  - Sensor Inactivity
- System Reporting:** A section with 'System Channels' set to '1 Channel Group'.

When you are finished programming the System settings, remember to save your changes. Explanations of the System configurations appear on the following pages. Also reference [Advanced Programming, System](#), Section 6.1.

	Option	Default	Function
Date & Time	Date		Once it is connected to UltraSync the Date and time are automatically synced.
	Time (hh:mm:ss)		Once it is connected to UltraSync the Date and time are automatically synced.
Time Zone	Hours Offset	UTC 5 ET	EST is UTC-5, CST is UTC-6, MT is UTC-6, PST is UTC-7.
	Minutes Offset	0	This is used in other locations throughout the world.
Daylight Saving Time	Start Month	Mar	Standard
	Start Week	Second	Standard
	End Month	Nov	Standard
	Start Month	First	Standard
System Timers	Siren Time (0-99) Minutes	4	The siren time sets the time in minutes that the siren output is active.
	Battery Test Time (0-99) Minutes	2	The battery test time sets the duration in minutes that the system will perform a dynamic battery test. The system will perform a dynamic battery test at the disarming of the first area or at midnight once each 24-hour cycle. Dynamic battery test is disabled when the test duration is set to 0. Dynamic battery test can also be run manually from a keypad.
	Battery Missing Time (0-65) Seconds	0	The battery missing time sets the interval in seconds that the system will perform a missing battery test. This option is disabled when the test interval is set to 0.
	AC Failure Report Delay (0-999) Seconds	300	The AC fail report delay sets the duration in seconds that the AC power is lost or restored before a communication is initiated. AC restore will report when power is maintained for this same duration.
	Cross Zone Time (30-999) Seconds	300	The Cross Zone time sets the duration in seconds whereby two or more sensors must trip before an alarm condition will be registered or the one sensor must trigger twice within this time period, or a continuous trip longer than 10 seconds. This feature only applies to sensors with the Cross Zone feature set in sensor options.
	Sensor Inactivity Time (0-65535) Minutes	0	Sensors programmed with Sensor Inactivity in the Sensor Options must be opened and closed within the time programmed here (in minutes). If they do not, a Sensor Inactivity will report. This feature can be enabled in the System Options menu. Default Sensor Inactivity option is off and this timer is set to 10080 minutes (7 days).

	Option	Default	Function
System Timers	Fire Supervise Time (120-65535) Seconds	14400	This applies only to wireless sensors programmed as fire type. Sensors send a reduced packet count supervisory signal every 60 minutes (check your sensor manual for most up to date details). If no supervisory signal is received by the panel within the time specified here then the sensor will be reported as missing. When set to 0 the default of 14,400 seconds (4 hours) will be used. Check your local regulations for the correct value to use.
	Burg Supervise Time (120-65535) Seconds	14400	This applies only to wireless sensors programmed as non-fire type. Sensors send a reduced packet count supervisory signal every 60 minutes (check your sensor manual for most up to date details). If no supervisory signal is received by the panel within the time specified here then the sensor will be reported as missing. When set to 0 the default of 43,200 seconds (12 hours) will be used. Check your local regulations for the correct value to use.
System Options	Panel Zone Doubling	Off	If enabled, the eight (8) hardwired sensor inputs will be doubled to support sixteen (16) sensors. The terminals for Sensor 1 will represent sensors 1 and 9, and the terminals for sensor 2 will represent sensor 2 and 10 etc. This option cannot be selected for sensors other than the eight sensors on the main CPU. This option cannot be used in conjunction with the DEOL option.
	Panel Box Tamper	Off	The system has a built-in normally closed tamper switch that will sound the siren if the tamper switch is opened or the wires are cut. This option will enable or disable this tamper switch.
	System Sensor Tamper	Off	If enabled, the system will monitor all sensors, except fire sensors, for Dual End of Line (DEOL). A short or open circuit on a DEOL will activate sensor tamper alarms. This feature cannot be used if Panel Zone Doubling is enabled.
	Disable Hardwire Sensors	Off	If enabled, the system will disable all hardwired sensor inputs on the CPU.
	Sensor Inactivity	Off	If enabled, the system will monitor each sensor for activations. If no activations occur within the sensor activity time then a failed sensor activity report may be reported via the selected communication channel and a failed sensor activity message set in the system event log. For a sensor to be eligible for activity monitoring, it must have <a href="#">Sensor Inactivity Test</a> set in Advanced Programming, Sensor Options.  The Sensor Inactivity Time is set in Advanced Programming, System – <a href="#">System Timers</a> .
System Reporting	System Channel	1 Channel Group	The Channel Group that the system will send system events to.



## 5.5 Programming Reporting and Notifications

Click on the Settings bar, and then select **Reporting and Notifications** from the drop down menu to see the list of programmable items.

With the Channels screen selected you can program a communication path for events to be sent from the system to a selected destination.

The system can support a total of 16 channels; each channel is identified by a unique channel number, which cannot be altered, and remains as the key reference for each channel.

The screenshot shows the 'Settings Selector' interface. At the top, there is a blue header with the text 'Settings Selector'. Below it is a dropdown menu currently set to 'Reporting and Notifications'. A blue 'Save' button is positioned below the dropdown. The main area of the interface is titled 'Select Channel to Configure:'. A dropdown menu is open, listing 16 channels: '1 Central Station Primary', '2 Central Station Backup 1', '3 Central Station Backup 2', '4 Email 1', '5 Email 2', '6 Email 3', '7 Email 4', '8 Email 5', '9 Email 6', '10 Email 7', '11 Email 8', '12 Email 9', '13 Email 10', '14 Email 11', '15 Email 12', and '16 Email 13'. The first option, '1 Central Station Primary', is highlighted in blue. A blue arrow points to this highlighted option. Below the dropdown, there are several input fields: 'Channel Name' (partially visible as 'Cer'), 'Account Number' (with '0' entered), 'Format', 'Destination' (partially visible as 'Destinatio'), 'Language', 'Next Channel', 'Event List' (with '1 Event List' selected), and 'Attempts' (with '2' entered).

Choose a channel in the drop down menu and assign it attributes. Explanations of the Channel Configuration menu appear on the following page.

Also reference [Advanced Programming, Reporting and Notifications](#), Section 6.4.

When you are finished programming the Channel settings, remember to save your changes.

Option	Default	Function
Select Channel to Configure	1 Central Station Primary	
Channel Name	Central Station Primary	Custom names of the selected channel can be created here.
Account Number	Blank	This is the Account Number that will be reported with the event in email reports. When UltraSync format is selected, this field will not be used.
Format	UltraSync	This is the communication format for the selected channel. Select from: Use as Backup CID SIA 300 SIA 110 UltraSync Email-Push Notification
Dest Phone, Email or Push Notification	Blank	The phone number or email address of the selected destination.
Next Channel	Central Station Backup 1 Central Station Backup 2 Email 1 Email 2 Email 3 Etc.	If the channel selected is unable to deliver the event to the selected destination, the system will use this backup channel if the primary channel fails. The Next Channel specified here must be greater than the Channel Number.
Event List	1 Event List	Select the pre-programmed list of events that will be sent via this channel. The specific event in each event list is programmed in <a href="#">Advanced Programming, Event Lists</a> .
Attempts	2	Enter the number of times the system should try to send the events to the UltraSync server. After the number of attempts has been exhausted the system will try the Next Channel if specified.

## 5.6 Programming the Network

Click on the Settings bar, and then select **Network** from the drop down menu to see the list of programmable items.

Enter your network settings on this page.

### Settings Selector

Network ▾

**Up** **Down** **Save**

#### LAN configuration

IP Host Name

Enable DHCP

IP Address	192	168	0	103
Gateway	192	168	0	1
Subnet	255	255	255	0
Primary DNS	192	168	0	1
Secondary DNS	0	0	0	0

#### Remote Access PINs

Web Access Passcode

Download Access Code

Automation User Name

Automation PIN

#### Options

Enable Ping

Enable UltraSync

Monitor LAN

Always Allow DLX900

Enable Web Program

Explanations of the Network Configuration Menu appear on the following pages. Remember to save your changes when you are finished programming the Network settings.

Option	Default	Function
LAN Configuration		
IP Host Name	-	<p>The default IP Host Name is xgen. To access the web server without an IP address, simply type http://xgen into the web browser. Some browsers do not require http://.</p> <p>To change the IP Host Name, enter a new IP Host Name and hit the Save button. The saved change does not take effect until you log out of the Web server. PC's typically cache this address for about 10 minutes. If you used the default xgen host name and then change it, the new host name will not be useable for this time frame.</p> <p><b>Note:</b> This feature is not supported with Internet Explorer. This only works on the local LAN and with a Windows® PC, or an Apple MAC. The PC or MAC must have Netbios Name Service (NBNS) enabled. It does not work remotely over the internet. Remote access to the server is supported via the UltraSync Portal.</p>
Enable DHCP	off	Allows the system to be automatically assigned an IP address by the network.
IP Address	-	The IP address assigned to the system which enables it to connect to the local LAN. This will allow you to access the embedded web server from the system to program and view the status of the system. It is also used for alarm reporting.
Gateway	-	If required, the IP address of the router which is needed when remote IP communications are used.
Subnet	-	The subnet mask for the network. For example, 255.255.255.0 is the network mask for 192.168.1.0/24
Primary DNS	-	The IP address of the Primary Domain Name Server. The DNS is used to translate host names for time servers and UltraSync servers.
Secondary DNS	-	The IP address of the Secondary Domain Name Server, used if the Primary DNS is not available.
Remote Access PINS		
WEB Access Passcode	0	The UltraSync app requires the Web Access Code to get remote access to the panel. The default Web Access Passcode of 00000000 disables remote access. The system allows for an 8 digit numeric (only) code. Each owner should have a unique number.
Download Access Code	0	Enables remote access for DLX 900. This is a variable length code for the computer user. This code gives the DLX 900 software complete authority over all menus including those that are locked. For convenience DLX 900 will also try <b>installer</b> and <b>9-7-1-3</b> to allow a connection if the Download Access Code does not work. This is why changing the default installer PIN code is important. The default Download Access Passcode of 00000000 prevents remote access.
Automation User Name	Blank	Used when there is API integration
Automation PIN	Blank	Used when there is API integration
Options		
Enable Ping	On	Allows the system to respond to the PING command.

Option	Default	Function
Enable UltraSync	On	<p>This is an automatic feature. It is recommended you leave this setting on.</p> <p>Enable this option to allow the system to send email reports via the UltraSync servers. This is independent of the Web Access Passcode which when set to 00000000 will prevent the UltraSync app from connecting.</p> <p>If any channel is set to Email format reporting, then the system will override ignore this setting and allow email reporting via UltraSync cloud servers.</p> <p>If you wish to prevent connections to the system's cloud servers, then uncheck this option and do not use the UltraSync reporting format.</p> <p>Also reference the <a href="#">table</a> in Advanced Programming, Communicator.</p>
Monitor LAN	Off	<p>When the Monitor LAN option is enabled the panel will monitor the Ethernet port for a valid Ethernet cable. If the Ethernet cable is disconnected while this option is enabled and the panel is unable to communicate, it will log a Fail To Communicate event.</p>
Always Allow DLX 900	On	<p>Enabling this option will allow DLX 900 to connect <u>at any time</u> if the correct Download Access Code is provided.</p> <p>Disabling this option provides greater security by only allowing DLX 900 to connect when program mode is active. This allows the system to have DLX 900 access disabled until a user on site with physical access to the keypad enters program mode with a valid PIN code.</p> <p>The system will be in program mode if a user gains authorized access to the program menu via the keypad.</p>
Enable Web Programming	On	<p>Enabling this option will cause UltraSync Web Server and UltraSync app to always display Installer menus regardless of if the panel is in program mode or not.</p> <p>Disabling this option will hide the Installer menus on UltraSync Web Server and UltraSync app unless program mode is active. This provides greater security by keeping web programming disabled unless a user on site with physical access to the keypad enters program mode with a valid PIN code.</p> <p>The system will be in program mode if a user gains authorized access to the program menu via the keypad.</p> <p>UltraSync app requires the Web Access Code to access to the panel.</p>





## 5.7 Programming Automations (Scenes)

Click on the Settings bar, and then select **Automations (Scenes)** from the drop down menu to see the list of programmable items.

With the Scenes screen selected you can create scenes on schedules and determine which event types and device triggers will activate them.

Each scene can trigger up to 16 consecutive scene actions when certain conditions are met. This can save users time by automatically running multiple actions. A scene can be triggered manually, through a schedule, or via a system event.

Remember to save your changes when you are finished programming the Scene settings.

Scene Configuration										
Sequence	During		IF		Does		Then Perform		Up To	
		Activate Schedule		Area, Sensor, Schedule, User, or Action		Activate Event Type		Action 1		Action 16

Explanations of the [Scene Configuration Menu](#) appear on the following pages.

Also reference [Advanced Programming, Scenes](#), Section 6.18.

Settings Selector

Automations (Scenes) ▼

Save

Select Scene to Configure:

1 Scene ▼

Scene Name

Scene Trigger

When Should Scene Work

Always On ▼

Scene Trigger Type

Entry Delay ▼

Activate Area

disabled ▼

Scene Result 1

Device

disabled ▼

Scene Result 2

Device

disabled ▼

Scene Result 3

Device

disabled ▼

Scene Result 4

Device

disabled ▼

Scene Result 5

Device

disabled ▼

## Example Scene

1. Enter a scene name.
2. Select the **When Should Scene Work** drop down menu to restrict when the scene will be enabled.
3. Select the event that will trigger the automation using the **Scene Trigger Type** drop down menu. Choices here dynamically change the “Activate” selections.
4. Select **Activate ( - - - )** to assign what that triggers applies to.
5. Select the **Scene Result**.
6. Press **Save**.

# Scene Configuration Menu

Option		Default	Function
Select Scene to Configure			The system can support a total of 16 Scenes. Each Scene is identified by a unique number, which cannot be altered, and remains the key reference for each Scene.
Scene Name			Each Scene can be configured with a custom 32 character name. The name is displayed wherever a Scene is referenced on the system.
Scene Trigger	When Should Scene Work	Always On	Select the Schedule that controls when this Scene is active. If the current date and time is outside of the selected schedule, then the Scene will not run.
	Scene Trigger Type	Disable	Select the event that will trigger this Scene. Choices here dynamically change the "Activate" selections. You can reference Activate Events list in <a href="#">Advanced Programming, Scenes</a> .
	Activate (-----)	Disabled	Select what triggers the Scene.
Scene Result 1 Device		Disabled	<p>Each scene can perform up to 16 Scene Actions. These are simplified actions that allow you to control devices on your system.</p> <p>There are two types of Results</p> <ol style="list-style-type: none"> <li>1. Alarm System Results</li> <li>2. Z-Wave Device Results.</li> </ol> <p>Alarm System Results</p> <p>Result Type - The event of the Action Result to perform. See Advanced Programming, Scenes and the Scene Action and <a href="#">Scene Action Events Types</a> for reference.</p> <p>Result Number - Select the area / scene / camera number to control:</p> <p>Z-Wave Device Result</p> <p>To display Z-Wave Result Types you must first learn in a Z-Wave device. The Z-Wave device name will then appear.</p> <p>Device – select the Z-Wave device you want to control</p> <p>Z-Wave Type 8 Setting 1 – depends on Z-Wave device. May include options such as On, Off, Heat, Cool, Auto, Up, Down, Lock, Unlock.</p>
Scene Result 2 Device		Disabled	
Scene Result 3 Device		Disabled	
Scene Result 4 Device		Disabled	
Scene Result 5 Device		Disabled	
Scene Result 6 Device		Disabled	
Etc.		Etc.	
Etc.		Etc.	



## 5.8 Programming Schedules

Click on the Settings bar, and then select **Schedules** from the drop down menu to see the list of programmable items.

With the Schedules screen selected you can create up to 96 schedules, each having four time and day periods.

Explanations of the Schedules Configuration menus appear on the following pages. Also reference [Advanced Programming, Schedules](#), Section 6.6.

Remember to save your changes when you are finished programming the Schedules settings.

The screenshot displays the Schedules Configuration interface. At the top is a 'Settings Selector' with a dropdown menu set to 'Schedules' and three buttons: 'Up', 'Down', and 'Save'. Below this is a section for selecting a schedule to configure, with a dropdown menu showing '1 Schedule' and a text input field for the 'Schedule Name'. The main area contains four configuration panels, each for a different time and day period:

- Time and Days 1:** Start Time (hh:mm) and End Time (hh:mm) are both set to 00:00. Days listed are Monday, Tuesday, Wednesday, Thursday, Friday, Saturday, Sunday, Holidays 1, and Holidays 2, each with an unchecked checkbox.
- Time and Days 2:** Start Time (hh:mm) and End Time (hh:mm) are both set to 00:00. Days listed are Monday, Tuesday, Wednesday, Thursday, Friday, Saturday, Sunday, Holidays 1, and Holidays 2, each with an unchecked checkbox.
- Time and Days 3:** Start Time (hh:mm) and End Time (hh:mm) are both set to 00:00. Days listed are Monday, Tuesday, Wednesday, Thursday, Friday, Saturday, Sunday, Holidays 1, and Holidays 2, each with an unchecked checkbox.
- Time and Days 4:** Start Time (hh:mm) and End Time (hh:mm) are both set to 00:00. Days listed are Monday, Tuesday, Wednesday, Thursday, Friday, Saturday, Sunday, Holidays 1, and Holidays 2, each with an unchecked checkbox.

# Schedules Configuration Menu

	Option	Default	Function
--	--------	---------	----------

	Select Schedule to Configure	1 Schedule 1	The system can support a total of 96 schedules. Each schedule is identified by a unique schedule number, which cannot be altered, and remains as the key reference for each schedule.
	Schedule Name	Schedule 1	Each schedule can be configured with a custom 32 character name. The area name is displayed wherever a schedule is referenced on the system.

Up to 16 Start and Stop times can be created.

**Note:** The system handles schedules that span midnight automatically

## Time and Days 1 -16

Start Time (hh:mm)	-	Enter in the start time
End Time (hh:mm)	-	Enter in the stop time
Monday	-	Enter in the days of the week the schedule is to be active
Tuesday	-	
Wednesday	-	
Thursday	-	
Friday	-	
Saturday	-	
Sunday	-	
Holiday 1	-	
Holiday 2	-	Same as Holiday 1
Holiday 3	-	Same as Holiday 1
Holiday 4	-	Same as Holiday 1

## 5.9 Programming Holidays

Click on the Settings bar, and then select **Holidays** from the drop down menu to see the list of programmable items.

With the Holidays screen selected you can create up to four sets of holiday dates for the system. Set the number, name and date range for each holiday. Holidays are then assigned to the schedules and used to deactivate the schedule while the holiday is active. Remember to save your changes when you are finished programming the Holidays settings.

Explanations of the Holiday configurations appear below. Also reference [Advanced Programming, Holidays](#), Section 6.13.

		Option	Default	Function
Holiday Configuration Menu	Select Holiday List to Configure		n/a	The system supports up to 4 sets of holiday dates, each set can have up to 16 date ranges. Holidays are used as part of Schedules to control access to the system on specified dates.
	Holiday #		1 Holiday 2 Holiday 3 Holiday 4 Holiday	The system can support a total of 4 Holiday Sets. Each set is identified by a unique number, which cannot be altered, and remains as the key reference for each area.
	Holiday Name		n/a	Each holiday can be configured with a custom 32 character name. The name is displayed wherever a Holiday is referenced on the system.
	Start -End	Start Date	n/a	Select the date range for the Holiday by specifying the start and stop date. A total of 16 ranges can be entered for each Holiday.
		End Date	n/a	

## Example Holiday List

### Holiday 1 US Holiday List 2016

Date Range 1 -	01/01/2016	01/01/2016	New Year's Day	Friday, January 1
Date Range 2 -	30/05/2016	30/05/2016	Memorial Day	Monday, May 30
Date Range 3 -	04/07/2016	04/07/2016	Independence Day	Monday, July 4
Date Range 4 -	05/09/2016	05/09/2016	Labor Day	Monday, September 5
Date Range 5 -	24/11/2016	24/11/2016	Thanksgiving Day	Thursday, November 24
Date Range 6 -	26/12/2016	26/12/2016	Christmas Day (observed)	Monday, December 26**
Date Range 7 -				
Date Range 8 -				
Date Range 9 -				
Date Range 10 -				
Date Range 11 -				
Date Range 12 -				
Date Range 13 -				
Date Range 14 -				
Date Range 15 -				
Date Range 16 -				



#### Office Worker

User Permission 1 – All Areas  
Permission Schedule 1 – 8am-  
8pm M-F, Holidays 1 (checked)

An office is not staffed during a public holiday and you want to **prevent** access to the building from staff on this date. First program the holiday dates in this section under “Holiday 1”, then go to Schedules and **check** “Holidays 1”, then assign that schedule to the User.

## 5.10 Lock PIN Share

Select **Lock PIN Share** from the drop down menu.

This function allows you to send user PINs to Z-Wave door locks from the panel.

Select the door lock you want to assign a PIN. Select an existing user (for their PIN) to send their PIN to the lock. You may also select all users at once.

You may also remove user PINs from a lock, either all at once or by individual user.

Lock PIN Share Instructions

1. Select Door Lock.
2. Select User(s).
3. Press Send or Remove Function Button.
4. Repeat Steps 1-3 as necessary.

Select Door Lock

(8) Front Door Lock ▼

Select User(s)

All Users ▼

Message Center

Ready

**Send PIN(s) to Lock**

**Remove PIN(s) from Lock**

## 5.11 Programming Cameras

Click on the Settings bar, and then select **Cameras** from the drop down menu to see the list of programmable items.

The system supports selected IP cameras. Contact your supplier for the correct model(s). Install camera according to the manual supplied with the camera. Once the camera has been connected to the same network as the system, proceed with the scanning of the camera from the system.

Also reference [Camera Setup Instructions](#), Section 9.

### Add a Camera Method 1 – Automatic Discovery

Press **Scan for New Cameras**.

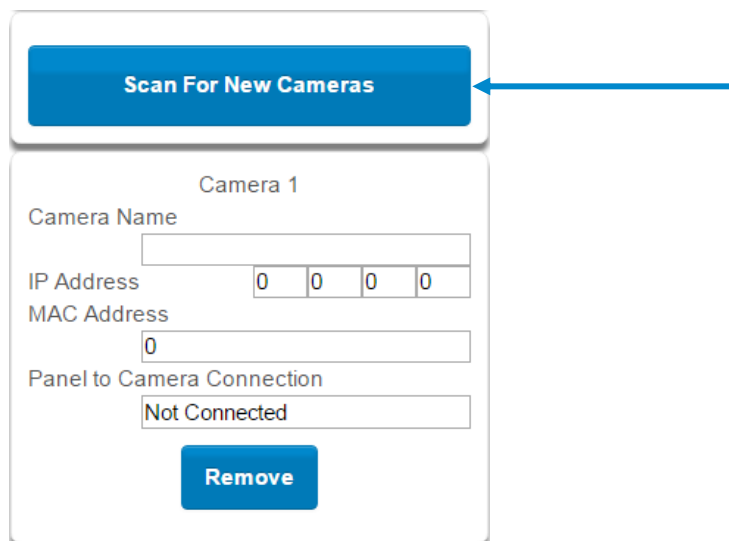

The image shows a user interface for adding a camera. At the top is a blue button labeled "Scan For New Cameras" with a blue arrow pointing to it from the right. Below this is a form titled "Camera 1". The form contains the following fields:

- Camera Name:
- IP Address:
- MAC Address:
- Panel to Camera Connection:

At the bottom of the form is a blue button labeled "Remove".

The scan results in an IP address and MAC address listing in the form fields shown.

### Viewing Cameras in UltraSync

1. Log in to UltraSync app.
2. Press **Cameras**.
3. You will now be able to view the live camera feed.

### Add a Camera Method 2 – Manual Entry

Reference [Advanced Programming, Cameras](#), Section 6.20.

### Removing Cameras

Reference [Advanced Programming, Cameras](#), Section 6.20.

	Option	Default	Function
Camera Menu	Scan For New Cameras	-	Finds cameras added to the same IP network as the system.
	Camera Configuration		Notification
	Camera Name drop down (all cameras)	This name can be up to 32 characters. Make sure the name matches the name you have set up in the camera app.	
	Camera Network Configuration		
	IP Address	IP address assigned to the camera by the premises network	
	MAC address	MAC address assigned to the camera by the premises network	
	Panel to Camera Connection	-	<p>Displays the last attempt by the panel to communicate with the camera on the LAN. The panel will try to communicate when:</p> <ol style="list-style-type: none"> <li>1. A clip is triggered</li> <li>2. Scan for New Cameras function is performed</li> <li>3. Once per day</li> </ol> <p>Note: This does not indicate a camera to server or cloud connection; only the LAN.</p>

## 5.12 Check Event History

The UltraSync Modular Hub allows you to check the history of events that have occurred in the system. Press **History** and this menu will appear:

The screenshot shows the 'Event History' interface. It includes a 'Select Date:' field with the value '01/26/2016', an 'Event Filter:' dropdown menu currently set to 'All Events', and four navigation buttons: a first button (|<), a previous button (<), a next button (>), and a last button (>|).

Navigate to events recorded in the system with the arrow buttons. You can select the date for finding events and use the Event Filter dropdown menus to select among alarm events or video events. The system stores 1024 alarm events and 1024 video events. The display shows 10 events at a time.

This screenshot is similar to the previous one, but the 'Event Filter:' dropdown menu is open, showing three options: 'All Events', 'Alarm Events', and 'Video Events'. The 'All Events' option is currently selected.

## 5.13 Check Connection Status

Click on the Settings bar, and then select **Connection Status** from the drop down menu to see the system connection status.

Also reference [Advanced Programming, System](#), Section 6.1.

Connections		Options	Function												
Connection Status Menu	Connection Status		Notification - Diagnostic												
	LAN Status	Not Linked, Configuring, Connected (system connection status)													
	Cellular State	<table border="0"> <tr> <td>1. Idle</td> <td>7. Configuring Protocol</td> </tr> <tr> <td>2. Getting Details</td> <td>8. Getting Echo</td> </tr> <tr> <td>3. Configuring Modem</td> <td>9. Connected</td> </tr> <tr> <td>4. Modem Connected</td> <td>10. Terminating</td> </tr> <tr> <td>5. Configuring PPP</td> <td>11. Idle</td> </tr> <tr> <td>6. Authenticating</td> <td></td> </tr> </table>		1. Idle	7. Configuring Protocol	2. Getting Details	8. Getting Echo	3. Configuring Modem	9. Connected	4. Modem Connected	10. Terminating	5. Configuring PPP	11. Idle	6. Authenticating	
	1. Idle	7. Configuring Protocol													
	2. Getting Details	8. Getting Echo													
	3. Configuring Modem	9. Connected													
	4. Modem Connected	10. Terminating													
	5. Configuring PPP	11. Idle													
	6. Authenticating														
	UltraSync Status	<table border="0"> <tr> <td>1. Idle</td> <td>5. Retry Delay</td> </tr> <tr> <td>2. Selecting Server</td> <td>6. Getting Server Hello</td> </tr> <tr> <td>3. Making Connection</td> <td>7. Connected</td> </tr> <tr> <td>4. Disconnecting</td> <td></td> </tr> </table>		1. Idle	5. Retry Delay	2. Selecting Server	6. Getting Server Hello	3. Making Connection	7. Connected	4. Disconnecting					
1. Idle	5. Retry Delay														
2. Selecting Server	6. Getting Server Hello														
3. Making Connection	7. Connected														
4. Disconnecting															
UltraSync Path	IP, Cellular														
Cellular Radio Details															
Cell Service	No Service, Restricted Service, Valid Service														
Signal Strength	-113 to -51														
Operator ID															
Radio Technology	GSM, UMTS														

## 5.14 Check Details

Click on the Settings bar, and then select **Details** from the drop down menu to view the system details.

Device Details		Detail
Control Name	Set in System Settings	
Device Unique ID (UID)	Unique ID number of the system	
Ethernet MAC Address	Ethernet MAC address assigned to the system by the premises network	
Control Model		
Firmware Version	of the system	
Hardware Version	" " "	
Bootloader	" " "	
Voice Version	" " "	
Website Version	" " "	
Memory Map Version	" " "	
Menu String Version	" " "	



## 6 Advanced Programming Using Web Server

Advanced settings are only accessible via the UltraSync Web Server, UltraSync app, or DLX 900.

Click the Advanced bar to display the advanced menu.

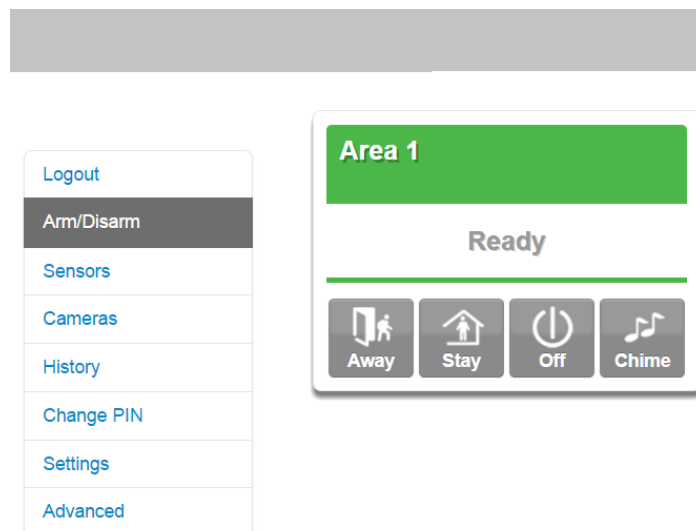

The Configuration Server page main tile contains different buttons than the settings tile.

**BACK:** Moves you back to the main selection.

**UP:** Moves you up one option through the programming options.

**DOWN:** Moves you down one option through the programming options.

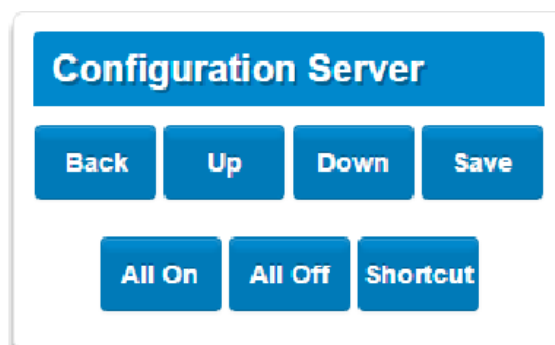

ALL ON / ALL OFF: Allows selecting or deselecting all the check boxes in menus like below.

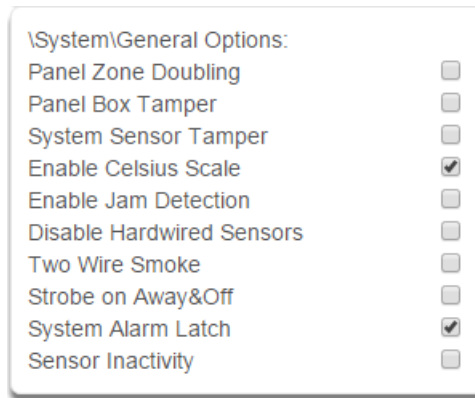

SHORTCUT: Allows quick navigation to the Advanced menu items or defaulting the system.

**Quick navigation to Advanced menu:**

A prompt will ask you to enter the Menu Shortcut. The format of the entry will be in a numerical format (X.Y.Z) following the [System Menu Tree](#) in Appendix 13. The first digit designates the top level menu. The second digit designates either the next menu level item or a specific the

For example, to navigate to the System, General Options, enter a 2.2.1.  
To navigate to Sensor # 3, enter 3.3.

**Defaulting the system:**

A prompt will ask you to enter the Menu Shortcut. The shortcut can be used to either default the entire system or individual menus. The format is entered in a numerical format (910.xxx).

A value of 910.910 defaults the entire sytem.

To default an individual menu, enter 910.xx where xx designates the menu item to default. For example, a value of 910.2 will default the System menu items. A value of 910.22 will default the Cameras menu. See the table below for the numerical value of each menu item.

910.1 Users	910.9 Auto Arm-Disarm	910.17 Event Lists
910.2 System	910.10 Devices	910.18 Channel Groups
910.3 Sensors	910.11 Permissions	910.19 Action Groups
910.4 Areas	910.12 Area Groups	910.20 Scenes
910.5 Reporting and Notification	910.13 Menus	910.21 Speech Tokens
910.6 Communicator	910.14 Holidays	910.22 Cameras
910.7 Schedules	910.15 Sensor Types	910.23 Network Servers
910.8 Actions	910.16 Sensor Options	

Table of Menu Default Values

## 6.1 Advanced Programming, System

Click the Advanced bar and select **System** from the menu to program system options.

System Options is used to configure system wide options, such as time and dates, system timers and maintenance.

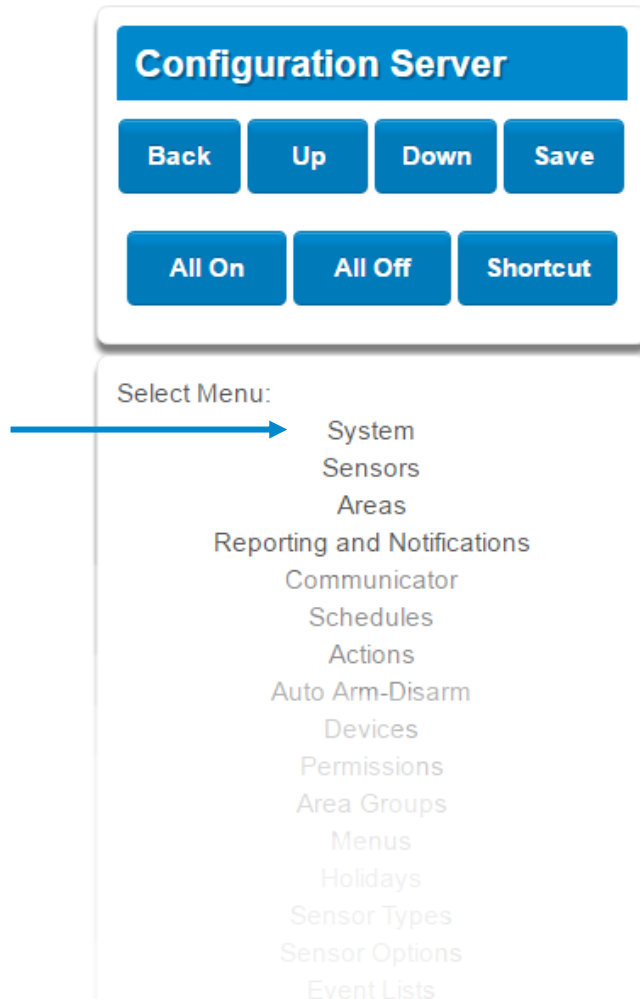

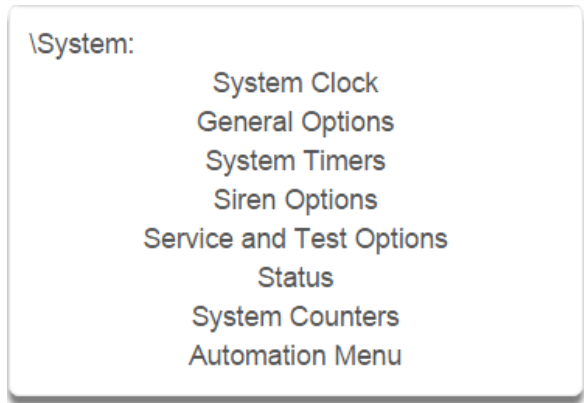

## System Submenus

### 1 System Clock



### 2 Clock Date and Time

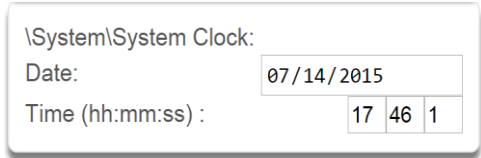

The system clock can manage day, time, time sensor, and day light saving time settings to ensure ongoing accurate time.

### 3 Time Zone Hours Offset / Minutes Offset

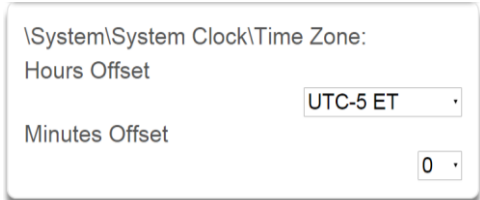

### 4 Daylight Saving Time

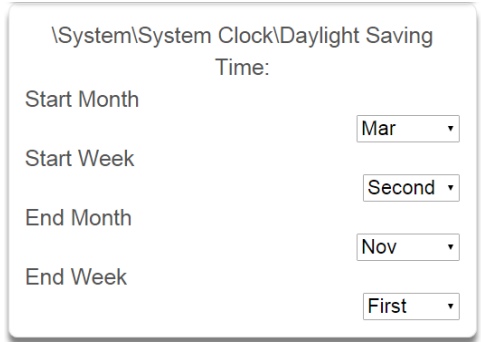

Start Of DLST – Month 1 to 12 of year; Week of month 1 to 4 and last  
 End Of DLST– Month 1 to 12 of year; Week of month 1 to 4 and last

When connected to an IP network the system clock can synchronize its time and date automatically with an Internet Time Server if configured in [Advanced Programming, Communicator](#).

System Clock

1 General Options

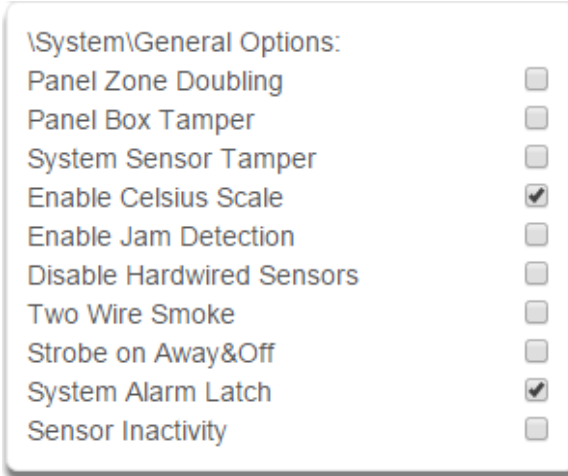

Option	Default	Function
Panel Zone Doubling	Off	If enabled, the two (2) hardwired sensor inputs will be doubled to support four (4) sensors. The terminals for Sensor 1 will represent sensors 1 and 3, and the terminals for sensor 2 will represent sensor 2 and 4. This option cannot be selected for sensors other than the two sensors on the main panel. This option cannot be used in conjunction with the DEOL option.
Panel Box Tamper	Off	The system has a built-in normally closed tamper switch that will sound the siren if the tamper switch is opened or the wires are cut. This option will enable or disable this tamper switch.
System Sensor Tamper	Off	If enabled, the system will monitor all sensors, except fire sensors, for Dual End of Line (DEOL). A short or open circuit on a DEOL will activate sensor tamper alarms. This feature cannot be used if Panel Zone Doubling is enabled.
Enable Celsius Scale	Off	Enable Celsius vs. Fahrenheit Scale.
Disable Hardwire Sensors	Off	If enabled, the system will disable all hardwired sensor inputs on the CPU.
Two Wire Smoke		If enabled, the system will accept installed two wire smoke detectors.
Strobe on Away & Off	Off	If enabled, the system strobe will flash when an area is set in away mode. The strobe outputs must be configured follow the area alarm event condition. The strobe is not activated on Disarm or Stay.
System Alarm Latch	On	If enabled, system alarms such as tampers, low battery, A/C fail and trouble requires a user with "Reset System Alarms" enabled in their current Permission Options to reset the alarm condition. If disabled, system alarms do not latch and can be reset when a user arms or disarms an area.
Sensor Inactivity	Off	If enabled, the system will monitor each sensor for activations. If no activations occur within the sensor activity time then a failed sensor activity report may be reported via the selected communication channel and a failed sensor activity message set in the event log. For a sensor to be eligible for activity monitoring, it must have <a href="#">Sensor Inactivity Test</a> set Advanced Programming, Sensor Options.

## 1 System Timers

\System\System Timers:  
 Siren Time [0-99] Minutes  
  
 Walk Test Time [0-99] Minutes  
  
 Strobe Time [0-99] Hours  
  
 Battery Missing Time [0-65] Seconds  
  
 Battery Test Time [0-99] Minutes  
  
 AC Failure Report Delay [0-999] Seconds  
  
 Phone Fault Delay [0-6000] Seconds  
  
 Phone Restore Delay [0-99] Seconds  
  
 Cross Zone Time [30-999] Seconds  
  
 Report Delay [15-45] Seconds  
  
 Holdup Delay [0-999] Seconds  
  
 Fire Verify Delay [0,120-255] Seconds  
  
 Sensor Inactivity Time [0-65535] Minutes  
  
 Fire Supervise Time [120-65535] Seconds  
  
 Burg Supervise Time [120-65535] Seconds

## Option

## Default

## Function

Option	Default	Function
Siren Time (0-99) Minutes	4	The siren time sets the time in minutes that the siren output is active.
Walk Test Time (0-99) Minutes	15	The walk test time is the duration in minutes before a zone walk test will automatically end.

	Option	Default	Function
System Timers	Strobe Time (0-99) Hours	3	The strobe time is the duration in hours that output(s) programmed to follow the strobe time will activate. The valid time selection in this segment is 0 to 99 hours, where '0' disables the Strobe Output. Output 2 on the CPU defaults to follow the Strobe Time when it is not assigned to an action.
	Battery Missing Time (0-65) Seconds	0	The battery missing time sets the interval in seconds that the system will perform a missing battery test. This option is disabled when the test interval is set to 0.
	Battery Test Time (0-99) Minutes	2	The dynamic battery test time sets the duration in minutes that the system will perform a dynamic battery test. The system will perform a dynamic battery test at the disarming of the first area or at midnight once each 24-hour cycle. Dynamic battery test is disabled when the test duration is set to 0. Dynamic battery test can also be run manually from a keypad.
	AC Failure Report Delay (0-999) Seconds	300	The AC fail report delay sets the duration in seconds that the AC power is lost or restored before a communication is initiated. AC restore will report when power is maintained for this same duration.
	Phone Fault Delay (0-6000) Seconds	0	The phone fault delay sets the duration in minutes before the phone line fault alarm condition is activated.
	Phone Restore Delay (0-99) Seconds	0	The phone restore delay sets the duration in seconds that the phone line fault condition must be restored before the phone fault alarm is reset.
	Cross Zone Time (30-999)	300	The Cross Zone Time sets the duration in seconds whereby two or more sensors must trip before an alarm condition will be registered or the one sensor must trigger twice within this time period, or a continuous trip longer than 10 seconds. This feature only applies to sensors with the Cross Zone feature set in sensor options.
	Report Delay (15-45) Seconds	30	The report delay is the duration in seconds that non-24 hour and non-fire type sensors will delay before reporting. This provides a valid user the opportunity to reset an unintended alarm condition before that event is reported.
Holdup Delay (0-999) Seconds	0	The holdup delay is the duration in second that a holdup delay sensor type will wait before it activates. If additional holdup activations occur during the holdup delay period then the holdup delay will immediately expire and set the holdup alarm. If a holdup delay sensor type is de-activated during the holdup delay period then the holdup alarm will reset and not activate.	

Option	Default	Function
Fire Verify Delay (0,120-255) Seconds	120	<p>The fire alarm verification feature is designed to reduce false alarms reported by smoke detectors.</p> <p>The system will wait 40 seconds to allow the smoke sensor to power up and settle. If a second trip occurs after this but before the end of the Fire Verify Delay time, a fire alarm will be generated. If no restoral is received after the first trip, a fire alarm will also be generated.</p> <p>The valid time selection in this segment is 120 to 255 seconds. The communicator will delay for a specified time before reporting the fire alarm</p>
Here are some scenarios:		
<div style="text-align: center; border: 1px solid black; padding: 5px; width: fit-content; margin: 0 auto;"> <b>Fire Alarm Verification Time = 120 seconds</b> </div> <p>The diagram illustrates the Fire Alarm Verification Time of 120 seconds through three scenarios on a timeline:</p> <ul style="list-style-type: none"> <li><b>Scenario 1:</b> A 1st Trip occurs at 0s. A Reset occurs at 13s, followed by Power Up at 40s. No alarm is reported.</li> <li><b>Scenario 2:</b> A 1st Trip occurs at 0s. No restoral is received, and a Fire alarm is reported.</li> <li><b>Scenario 3:</b> A 1st Trip occurs at 0s. A Reset occurs at 13s, followed by Power Up at 40s. The system enters a 'Waiting for second trip' phase. A 2nd Trip occurs at 133s, resulting in a Fire alarm and Fire alarm reported.</li> </ul>		
Sensor Inactivity Time (0-65535) Minutes	0	<p>Sensors programmed with Sensor Inactivity in the Sensor Options must be open and closed within the time programmed here (in minutes). If they do not, a Sensor Inactivity will report. This feature can be enabled in "System Options". <a href="#">See Section 5.4.</a></p> <p>Default Sensor Inactivity option is off and this timer is set to 10080 minutes (7 days).</p>
Fire Supervise Time (120-65535) Seconds	14400	<p>This applies only to wireless sensors programmed as fire type. Sensors send a reduced packet count supervisory signal every 60 minutes (check your sensor manual for most up to date details). If no supervisory signal is received by the panel within the time specified here then the sensor will be reported as missing.</p> <p>When set to 0 the default of 14,400 seconds (4 hours) will be used. Check your local regulations for the correct value to use.</p>
Burg Supervise Time (120-65535) Seconds	14400	<p>This applies only to wireless sensors programmed as non-fire type. Sensors send a reduced packet count supervisory signal every 60 minutes (check your sensor manual for most up to date details). If no supervisory signal is received by the panel within the time specified here then the sensor will be reported as missing.</p> <p>When set to 0 the default of 43,200 seconds (12 hours) will be used. Check your local regulations for the correct value to use.</p>

System Timers



**1 Siren Options**

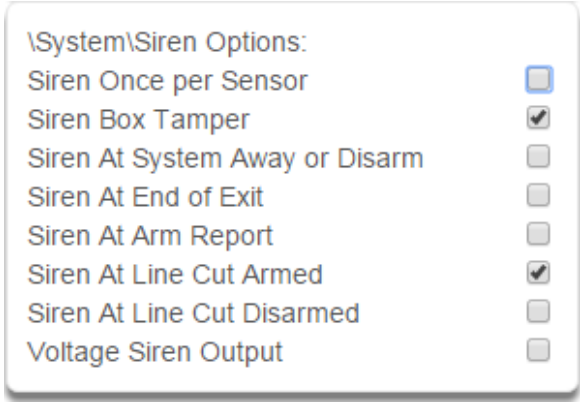

Siren Once Per Sensor

If enabled, the system will only activate the siren once per sensor in a given arm cycle and will not activate the siren again even if that siren time expires and that sensor reactivates. Every sensor will have one siren activation attempt before that sensor cannot reactivate the siren. If this option is not enabled, at the expiry of the siren time any sensor can reactivate the siren an unlimited number of times.

Siren Box Tamper

If enabled, the system enables the siren box tamper feature on the CPU Tamp2 terminals. If the siren box tamper is tripped (e.g. opening the siren cover or wires cut), then an event will be generated.

Siren At System Away or Disarm

If enabled, the system will activate the siren (Output 1) briefly each time the last area in the system is set in away mode or when the first area is disarmed by a keyfob. By default Output 1 is programmed to chirp. To enable this function by area, leave this option disabled in this section. Enable the “Siren at System Away/Disarm” in [Area Options](#) of Section 6.3 Advanced Programming, Areas for the area(s) you require.

Siren At End Of Exit

If enabled, the system will activate the siren (Output 1) briefly each time the system is set in away mode and the exit delay expires. By default Output 1 is programmed to chirp.

Siren At Arm Report

If enabled, the system will activate the siren (Output 1) briefly each time the system is set in away mode, with a keyswitch or wireless keyfob. The exit delay expires and a successful system arm report is acknowledged from the central station. The siren will chirp three times. By default Output 1 is programmed to chirp.

Siren At Line Cut Armed

If enabled, the system will set the siren for the siren time whenever the phone line is not detected and any area is armed. The phone line siren can be reset by the entry of a valid PIN.

Siren At Line Cut Disarmed

If enabled, the system will set the siren for the siren time whenever the phone line is not detected and all areas are disarmed. The phone line siren can be reset by the entry of a valid PIN.

Voltage Siren Output

If enabled, the system will alter the oscillating siren output suitable for horn speaker to one that is a steady DC output that is suitable for DC sirens.

### 1 Service and Test Options

\System\Service and Test Options:  
 Status Email Intervals  
 Status Email Time  
 Service Phone Number [0-9]

### 2 Status Email Intervals

\System\Service and Test Options:  
 Status Email Intervals

If enabled, the system will report a system status email via one or more email channels. The number entered for Status Email Interval is the number of days between status reports. For example entering a 7 will cause a report to be sent every 7 days.

The interval starts from either the first time you program an interval in here or when it is powered up.

This is sent via System Event Reporting – Reporting Channels.

### 3 Status Email Time

\System\Service and Test Options:  
 Status Email Time (hh:mm) :

The status email time sets the time of day that the status email will report. This is set as 24-hour time in hours and minutes.

### 4 Service Phone Number

\System\Service and Test Options:  
 Service Phone Number [0-9]

This feature is currently not used. Program the Company name and telephone number directly into the UM-1820E keypad by tapping Menu – Settings – Labels – Installer. When the user taps the SOS – Installer icons, this contact information will be displayed on the keypad.

### 1 Status

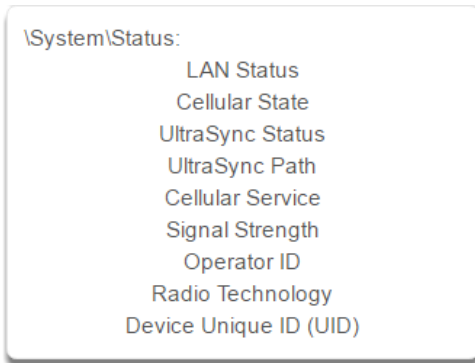

This menu provides diagnostic information on the connection status of the system.

### 2 LAN Status

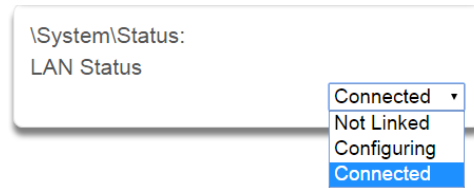

Status of the connection to the Local Area Network.

### 3 Cellular State

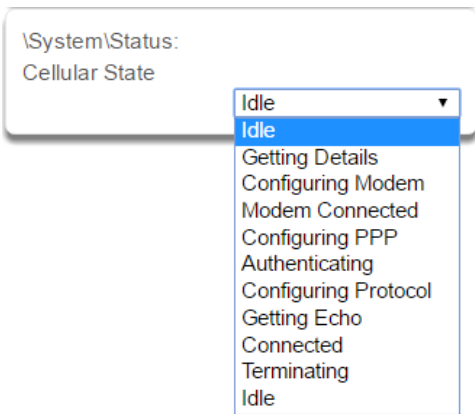

Status of the connection to the cellular radio network.

### 4 UltraSync Status

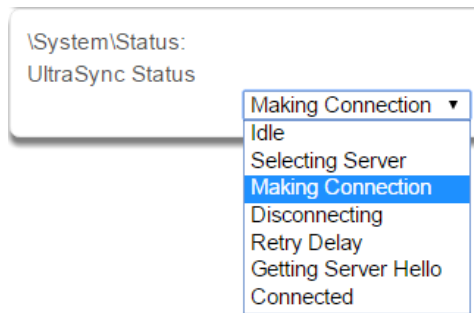

Status of the connection to the cloud servers.

### 5 UltraSync Path

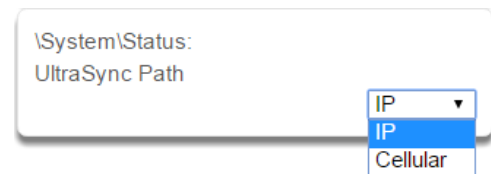

When connected to the cloud servers whether this is via LAN (Ethernet/WiFi) or cellular radio.

### 6 Cellular service

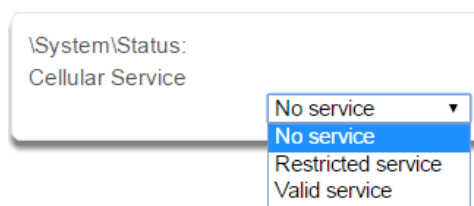

When connected to the cellular radio network this will display what level of service is provided. If the optional radio module is installed with a valid SIM card, and this shows restricted service, please contact your service provider as your SIM card may not be provisioned correctly.

### 7 Signal Strength

\System\Status:  
Signal Strength

If the optional radio module is installed with a valid SIM card, this will show the numeric signal level.

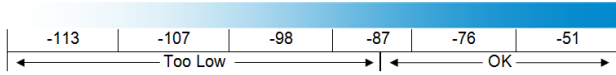

If the reported value is -121 to -86 then the signal level is too low. Install an external antenna to improve the signal level.

If the reported value is -87 to -51 then the signal level is OK.

### 9 Radio Technology

\System\Status:  
Radio Technology

GSM ▼

- GSM
- UMTS
- UMTS Type 3
- Type 4
- Type 5
- Type 6
- Type 7
- Type 8
- Type 9
- Type 10
- Type 11
- Type 12

If the optional radio module is connected to the network this will display the connection technology such as GSM or UMTS.

### 8 Operator ID

\System\Status:  
Operator ID

If the optional radio module is connected to the network this will display the ID of the network operator.

### 10 Device Unique ID (UID)

\System\Status:  
Device Unique ID (UID)

Unique ID number of the radio module.

**1 Counters**

\System\System Counters:  
Swinger Shutdown [1 - 3]

Swinger Shutdown is a false alarm prevention feature prevents a single sensor from activating more than a programmed number of times during a single arming period. After a certain number of alarms caused by the same sensor within the same arming period, the system will then shutdown that sensor for the remainder of that arming period. The sensor will be reactivated when the system is disarmed or rearmed to any security mode.

See SIA CP-01-2010 [Programmable Features](#) Table for reference.

**1 Automation Menu**

\System\Automation Menu:  
Automation User Name  
Automation PIN

This menu allows integration of 3rd party apps and devices.

**3 Automation Pin**

\System\Automation Menu:  
Automation PIN

Used when there is API integration

**2 Automation User Name**

\System\Automation Menu:  
Automation User Name

Used when there is API integration

## 6.2 Advanced Programming, Sensors

Click the Advanced bar and select **Sensors** from the menu to program sensor options.

A sensor (sometimes referred to as a zone or input) on the system is a single physical hardwired connection or a non-physical wireless connection. Additionally sensors on the system can be used as logic inputs within actions and / or be configured as one of many sensor types. See [Advanced Programming, Actions](#).

**Note:** After you have finished programming a sensor, be sure to advance the sensor number in the drop down menu when programming the next sensor. Otherwise you will over-write the sensor configuration you just programmed.

### Sensor Submenus

**1 Sensor Number**

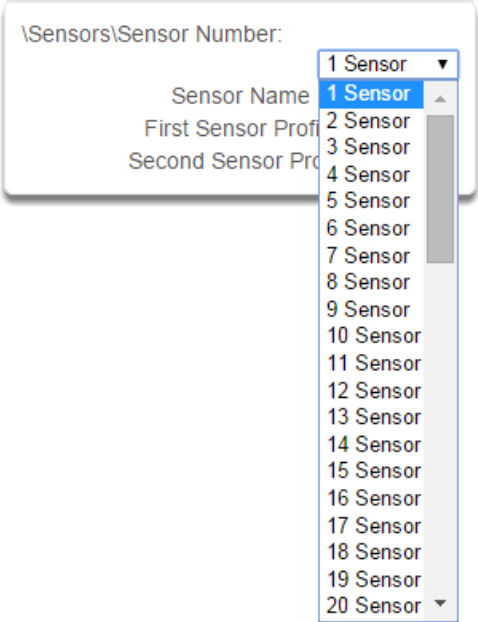

The system can support a total of 64 sensors. Each sensor is identified by a unique sensor number, which cannot be altered, and remains as the key reference for each sensor.

**2 Sensor Name**

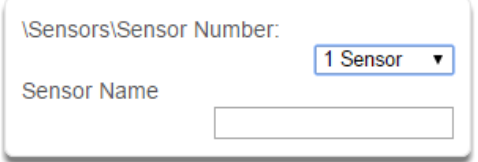

Each sensor can be configured with a custom 32 character name. The sensor name is displayed wherever a sensor is referenced on the system.

**3 First Sensor Profile**

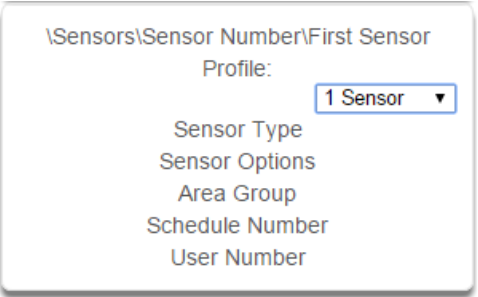

Sensor profiles determine the sensor type (Entry, 24 hour, fire, key switch, etc.) and the sensor options (bypass, force arm, twin trip, stay mode, etc.). Sensor profiles also determine the area in which the sensor resides in. Additionally, each profile has a schedule that the system uses to determine which of the two sensor profiles to use and when to use them.

#### 4 Sensor Type

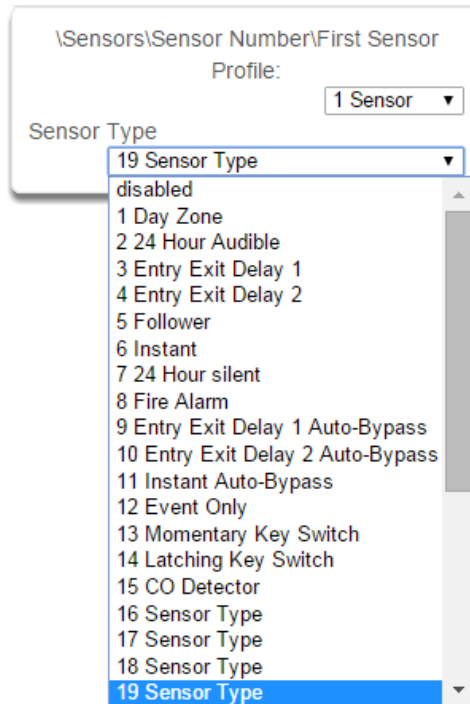

One of 32 configurable sensor types may be allocated to any sensor's sensor type. Each sensor type can behave independently between an arm and disarmed state. Sensor types determine the sensor attributes, siren attributes, and sensor attribute options.

Here is an example of a preset sensor type:

#### Sensor Type – 1 – Day Sensor

Sensor Type Armed	Sensor Type Disarmed
Sensor Attribute - Instant	Sensor Attribute - Local
Siren Attribute - Yelping	Siren Attribute - Silent
<b>Sensor Attribute Options:</b> Keypad Sounder      YES Report Delay          NO No Keypad Display    NO Momentary Switch     NO Sensor Inhibit (Bypass) NO	<b>Sensor Attribute Options:</b> Keypad Sounder      YES Report Delay          NO No Keypad Display    NO Momentary Switch     NO Sensor Inhibit (Bypass) NO

### 5 Sensor Options

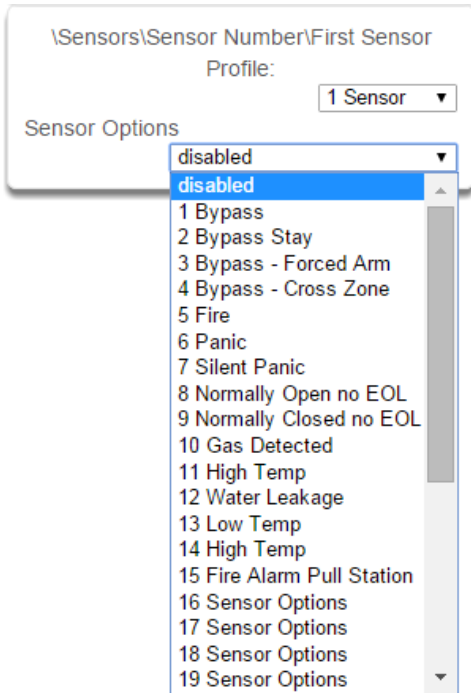

One of 32 configurable sensor options may be allocated to any sensor. Sensor options determine the sensor attributes such as a sensor's ability to be bypassed, force arm, cross zone, stay mode, etc. Additionally sensor options determine the sensor's reporting attributes.

One of 16 configurable schedules can be allocated to any sensor's schedule number. Sensor profile schedules determine when to allocate a sensor profile to a sensor. The first sensor profile has the highest priority and the second sensor profile has the lowest priority.

The panel will check if the current time and day fall within the schedule of the first sensor profile or if the schedule is disabled (thus always active). If the schedule is active then that profile is applied to that sensor.

If the first sensor profile's schedule is not active then it will check the second sensor profile. If the schedule is active then that profile is applied to that sensor.

### 6 Area Group (1-16)

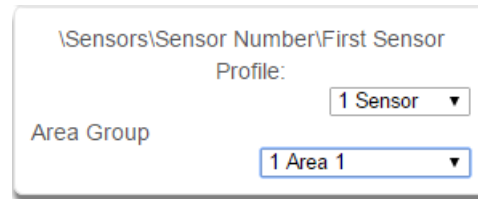

One of 16 configurable area groups can be allocated to any sensor's area group. Area groups are a list of system areas. When an area group is allocated to a sensor, that sensor will then belong to all the areas in the area group. If a sensor is assigned to multiple areas it will not arm until the last area is armed. It will also be disarmed when the first area is disarmed.

Ensure the correct Area Group is assigned to a sensor. If an area Group with no areas is used, then the sensor will never report.

### 7 Schedule Number

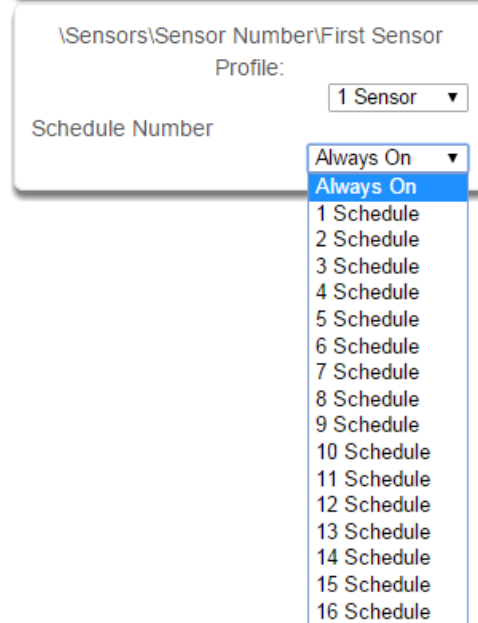
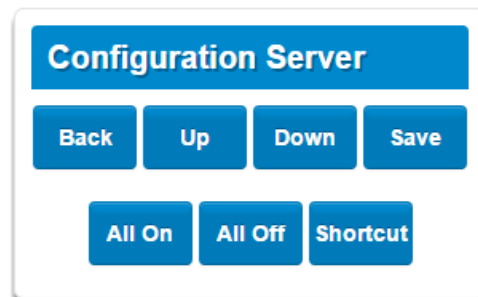



**8** User Number

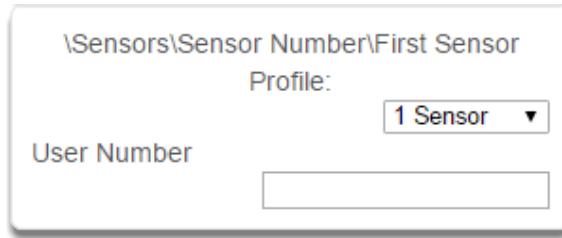

The sensor user number feature is used whenever the sensor type is set to “keyswitch”. Instructions for users’ configurations are in Section 7 – [Users and Permissions](#). One of 256 configurable users can be allocated to any sensor’s user number. The system’s sensor profile user number is a powerful feature that is used to apply the selected user’s attributes to a keyswitch operation. When the keyswitch sensor is activated, the system will check the user permissions and permission schedules to determine which areas are accessible. Additionally, area open and close reports will also report the user number selected in this option.

**Note:** If the user number is programmed to 0, the system will use a default User number of 999 and will operate on all areas in the sensors area group.

**9** Second Sensor Profile (Refer to First Sensor Profile)

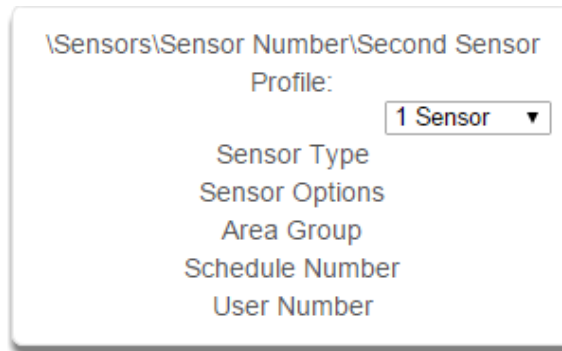

Example Diagram

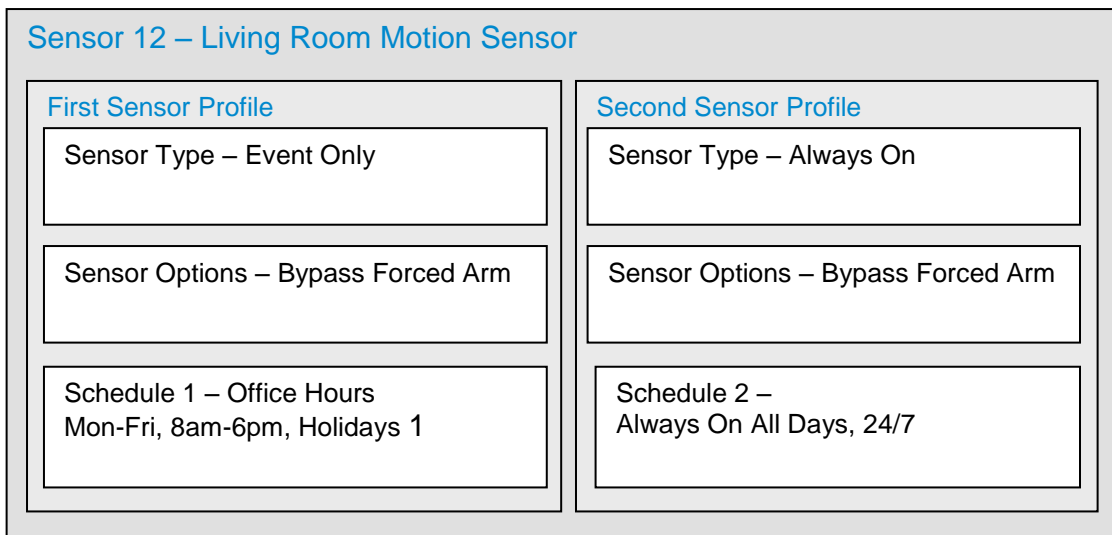

Sensor Programming

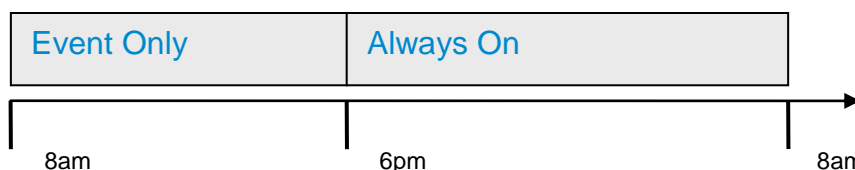

## 6.3 Advanced Programming, Areas

Click the Advanced bar and select **Areas** from the menu to program area options.

Areas Submenus

**1 Area Number**

Areas\Area Number:

- Area Name
- Area Entry-Exit Times
- Area Options
- Area Timers
- Area Type Settings
- Area Event Reporting

1 Area ▾

1 Area

2 Area

3 Area

4 Area

**2 Area Name**

Areas\Area Number:

1 Area ▾

Area Name

Depending on the model, the system can support up to 96 areas. Each area is identified by a unique area number, which cannot be altered, and remains as the key reference for each area.

Each area can be configured with a custom 32 character name. The area name is displayed wherever an area is referenced on the system.

### 3 Area Entry-Exit times

Areas\Area Number\Area Entry-Exit Times:

2 Area ▾

Entry Time 1 [0,30-240] Seconds

Exit Time 1 [0,45-255] Seconds

Entry Time 2 [0,30-240] Seconds

Exit Time 2 [0,45-255] Seconds

Stay Entry Time [0,30-240] Seconds

The system uses the area entry and exit timers to delay the activation of an alarm event when entry/exit sensor types are activated.

When an area is turned on, it will start an Exit 1 timer. While an Exit 1 timer is running – Entry 1, Entry 2, and Follower sensor types will not create an alarm.

When the Exit 1 timer expires it will start the Exit 2 timer. While an Exit 2 timer is running – Entry 2 sensors will not create an alarm.

Once all exit delays are expired, an activation on an Entry 2 sensor type will start an Entry delay with the Entry 2 time, and an activation of an Entry 1 sensor type will start an Entry delay with the Entry 1 time.

If an entry delay is running and a sensor is activated with an entry time that is less than the time remaining, the timer will be reduced to the time of that new sensor.

When configuring Area 2 and above, the Entry and Exit times default to 0. When the Entry and Exit times are set to 0, the system uses the Entry and Exit times configured for Area 1. A non-0 value will use that value for the Entry or Exit time.

Activation of a Follower sensor while an entry timer is not running will create an instant alarm.

If a sensor is in more than 1 area, the sensor will use the have the longest entry and exit delay time of the programmed area. If an area greater than 1 has the time set to 0, that area will use the time programmed in Area 1.

#### Stay Entry Time

The stay entry time is the entry warning time that applies to all sensors armed in the stay mode. This stay entry time only applies to Entry/Exit zones.

## 4 Area Options

Areas\Area Number\Area Options:

1 Home ▼

Arm-Disarm Reports	<input checked="" type="checkbox"/>
Quick Arm Away (No PIN)	<input type="checkbox"/>
Arm In Stay If No Exit	<input checked="" type="checkbox"/>
Quick Disarm - Stay Mode	<input type="checkbox"/>
Siren Chirp Away	<input type="checkbox"/>
Siren Chirp Stay	<input type="checkbox"/>
Force Arm With Bypass	<input type="checkbox"/>
Force Arm Without Bypass	<input type="checkbox"/>
Manual Fire	<input checked="" type="checkbox"/>
Manual Auxiliary	<input checked="" type="checkbox"/>
Manual Panic	<input type="checkbox"/>
Use Area 1 Options	<input type="checkbox"/>
Bypass Requires PIN	<input type="checkbox"/>
Manual Panic is Silent	<input type="checkbox"/>
Arm In instant If No Exit	<input type="checkbox"/>

### 1. Arm/Disarm Reports

If enabled, this area will send open and close reports via one or more appropriately configured channels.

### 2. Quick Arm Away (No PIN)

If enabled, this area can be armed in away mode via a single away mode key press. When an area is armed via quick away mode, the closing user number is the default user of 999.

### 3. Arm In Stay If No Exit

If enabled, Arm In Stay If No Exit will cause this area to arm in stay mode even when a user arms it in away mode, providing that an entry 1 or entry 2 sensor type is not triggered during the exit delay.

### 4. Quick Disarm - Stay Mode

If enabled, this will allow the stay mode to be disarmed by pressing the stay key on the keypad. This is only possible if there is no alarm active and the stay entry delay is currently running.

At the end of the stay entry delay or if there is an area alarm, the stay mode can only be disarmed via a valid user PIN.

### 5. Siren Chirp Away

If enabled, the system will activate the siren (Output 1) briefly each time this area is set in away mode or disarmed with a key-switch or wireless keyfob. By default Output 1 is programmed to chirp.

### 6. Siren Chirp Stay

If enabled, the system will activate the built-in siren briefly each time this area is set in stay mode with a key-switch sensor or wireless keyfob.

### 7. Force Arm With Bypass

If enabled, the area can be armed even if sensors are not ready. Any sensors that are not ready will automatically be bypassed. The bypass will be logged in the event history.

The automatic bypass will be applied when the sensor is capable of causing an alarm condition due to a state change such as an area arming, schedule or action. This avoids false alarms.

If an auto-bypassed sensor becomes ready after it is armed, that sensor will automatically remove the bypass, log the bypass restore, and optionally report the bypass restore.

Individual sensors can be made “force armable with auto-bypass” by leaving this area option off, then enabling Forced Arm Enable in Sensor options, and enabling Sensor Inhibit (Bypass) in the Sensor Type Profile.

### 8. Force Arm Without Bypass

If enabled, the area can be armed even if sensors are not ready. Any sensors that are not ready will NOT be automatically be bypassed and may cause an alarm condition because they could still be in a not ready state once the area becomes armed.

This option is overridden if the Force Arm With Bypass is enabled.

Individual sensors can be made “force armable without auto-bypass” by leaving this area option off, then enabling Forced Arm Enable in Sensor options, and disabling Sensor Inhibit (Bypass) in the Sensor Type Profile.

### 9. Manual Fire

If enabled, the manual fire button will be enabled on keypads. Press and hold for 2 seconds to send a fire event. Default is off.

### 10. Manual Auxiliary

If enabled, the manual auxiliary button will be enabled on keypads. Press and hold for 2 seconds to send an auxiliary event. Default is off.

### 11. Manual Panic

If enabled, the manual panic button will be enabled on keypads. Press and hold for 2 seconds to send a panic event. Default is off.

### 12. Use Area 1 Options

If enabled, the selected area will use the options chosen for Area 1. The panel ignores all other selections made; it overrides them to instead use the options chosen for Area 1. Default is on.

### 13. Bypass Requires PIN

If enabled, a valid PIN code with access to this area is required to bypass sensors in this area.

### 14. Manual Panic is Silent

If enabled (in **Settings**), manual panic alarms will not trigger an audible alarm.

### 15. Arm In instant If No Exit

If enabled, this area will arm in Stay Instant mode when attempting to arm in Away mode and there is no exit.

## Notes on Force Arming, Bypass, and Auto-Bypass

To arm an area it must first be “Ready to Arm”. This means all sensors in that area must be closed.

For example, if the front door is open, then a user would need to close it first and ensure there is no movement in the reception area. This provides the Ready to Arm status in Area 1 that is needed before attempting to arm. This is not always user friendly or practical.

The term force arm refers to the ability to arm an area even though sensors are not ready. It is usually only used with motion sensors as these are self-restoring and will be restored by the time the exit delay ends (e.g. the person arming the system leaves the building causing the Reception PIR to restore.)

If the front door is not closed properly then Area 1 would go into alarm at the end of the Exit time. To avoid this false alarm we enable “**Force Arm With Auto-Bypass**” so all sensors that are not closed (i.e. not ready) by end of the exit time will be “Auto-Bypassed”.

If after the Area is armed, that sensor restores (e.g. the person double checks and secures the front door) then the Auto-Bypass will be removed from the sensor and it will be active. If subsequently the sensor is triggered then Area will go into alarm.

Auto-bypass will be applied (if enabled, and if necessary) to a sensor whenever a change in state occurs that would result in an alarm condition. These include arming an area with a not-ready sensor, a sensor changing profile, Arm-Disarm function, or due to an action or schedule.

Enabling Auto-Bypass for the area will apply the feature to all sensors in that area as well.

In general disabling “Sensor Auto-Bypass” is not recommended because of the potential to create a false alarm but there are applications where it is desired. Use “**Force Arm Without Auto-Bypass**” at the area level to prevent sensors from being auto-bypassed when Force Armed.

AREA 1 - Office

Force Arm With Auto-Bypass  
 Force Arm Without Auto-Bypass

**SENSOR 1 – Door Reed Switch**

<b>SENSOR TYPE</b> <input type="checkbox"/> Sensor Auto-Bypass	<b>SENSOR OPTIONS</b> <input type="checkbox"/> Force Armed Enabled <input type="checkbox"/> Bypass
-------------------------------------------------------------------	----------------------------------------------------------------------------------------------------------

**SENSOR 2 – Reception PIR**

<b>SENSOR TYPE</b> <input type="checkbox"/> Sensor Auto-Bypass	<b>SENSOR OPTIONS</b> <input type="checkbox"/> Force Armed Enabled <input type="checkbox"/> Bypass
-------------------------------------------------------------------	----------------------------------------------------------------------------------------------------------

Areas Submenus

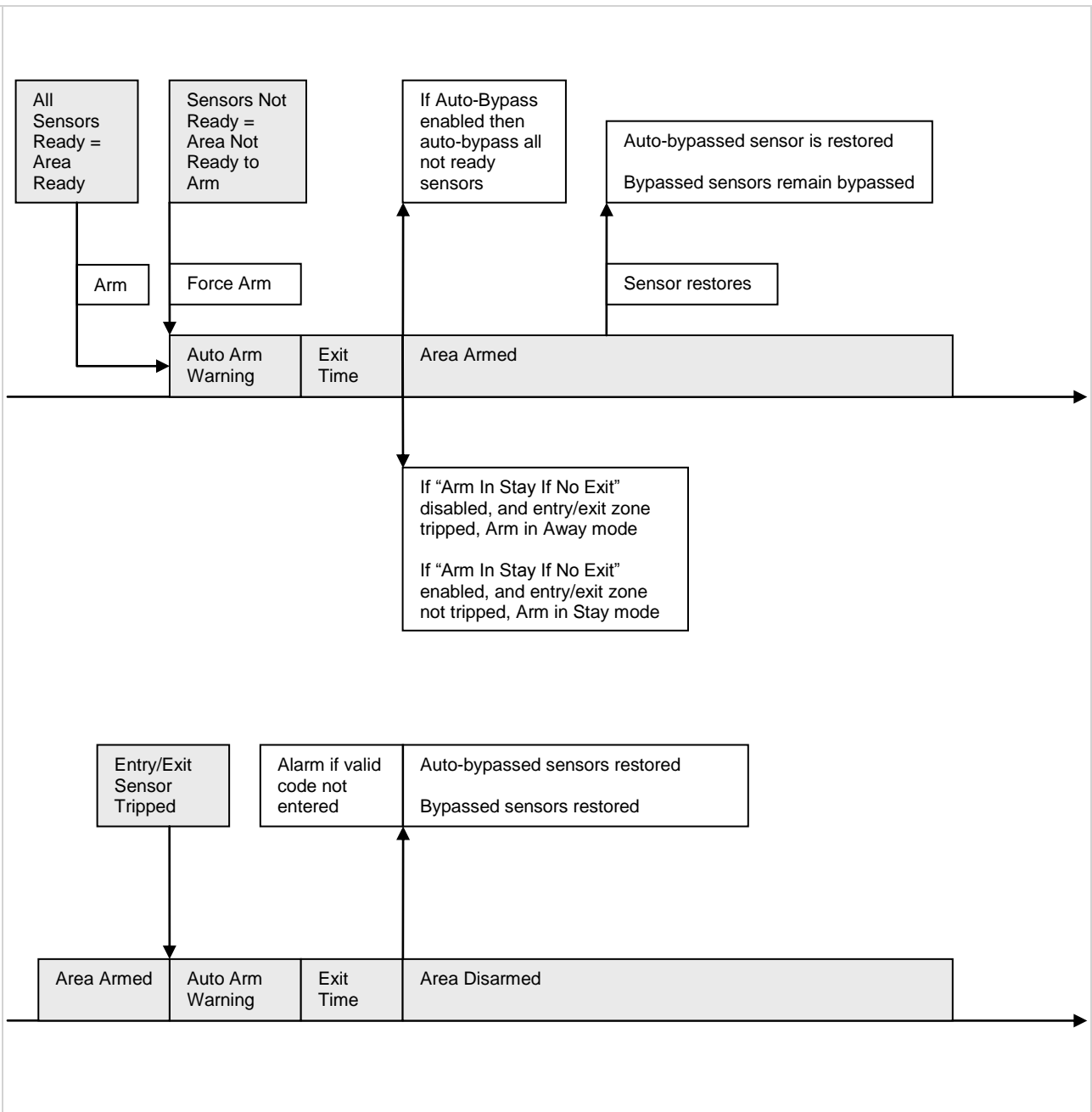

## 5 Area Timers

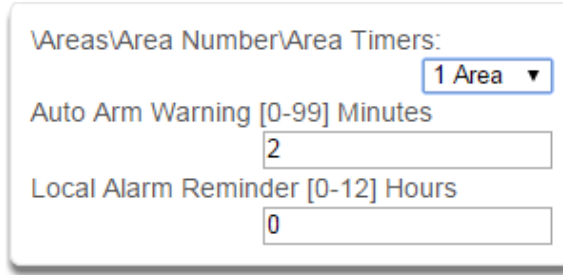

### Auto Arm Warning

If the area type is Standard and Arm / Disarm is configured, this timer delays arming by the minutes entered.

If the area type is Timed Disarm, Man Down, or Guard Tour, this setting is a warning time given to a user once the user's Disarm Time, Man Down Time, or Guard Tour Time has expired. During this warning time a user can cancel the automatic re-arming and event report by entering their code, this will also restart the appropriate user timer. At the end of the warning time the system will re-arm the area and send the appropriate event (closing, man down, guard tour fail).

If the area type is Early Open & Late Close, this timer sets the period after the start (opening) and after the end (closing) of the area type schedule that the area can be disarmed or armed. Otherwise an early to open or late to close report will be sent if enabled in user permissions. Fail to open and fail to close report will be sent if Arm-Disarm Reports is enabled in area options.

Valid values are from 0 to 99 minutes

### Local Alarm Reminder

If set, the local alarm reminder is the period in minutes between 0 and 999 that may elapse between actioning a local alarm and the local alarm reactivating if that sensor has remained open.

For example if a smoke detector is removed to change the battery the tamper will trip; if a user resets the alarm on the system but does not replace the smoke detector within the local alarm reminder time, then the fire alarm tamper will retrigger.

## 6 Area Type

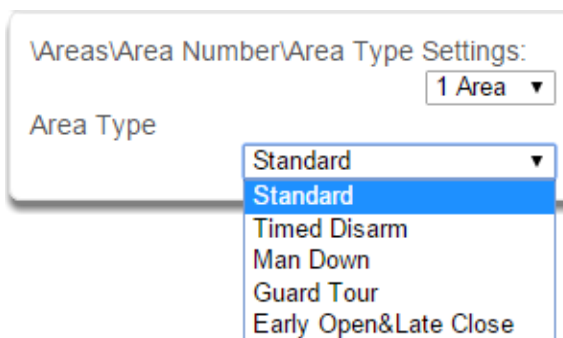

### Standard

The area functions as normal.

### Timed Disarm

Timed disarm is used when an authorised user can disarm an area for a predetermined period of time. At the end of this disarm time the area will start the auto-arm process ensuring that the area is not accidentally left disarmed.



The following conditions must be true before a timed area disarm function will occur.

- a. The area type must be set to Timed Disarm.
- b. The area type schedule must be active.
- c. The user's active profile's permission must have:
  - i. This area set in the permission's timed disarm area group.
  - ii. The permission must be in schedule.
  - iii. The permission's Area Type Override must NOT be set.

At the end of the user's disarm time, the Area Type Delay will activate for the set period. At the end of the Area Type Delay period the area will arm and start the Exit Delay and if configured, report a closing using via the last user number to have time disarmed the area.

At anytime during the timed disarm period, authorised users with Area Type Override set in their active profile can cancel the disarm time period by arming or disarming the area.

The user's permission determines how long the area will be disarmed for.

### Man Down

Man down is used when an authorised user(s) is working in a hazardous area (or the like), and there is a requirement that the user(s) regularly "check-in" to notify others that the user(s) is safe. If the authorised user(s) fails to perform this action the system can set an audible warning and send a report.

The following conditions must be true before man down function will occur.

- a. The area type must be selected to man down.
- b. The area type schedule must be active (after the start time and before the end time).
- c. The user's active profile's permission must have:
  - i. This area set in the permission's man down group.
  - ii. The permission must be in schedule.
  - iii. The permission's Area Type Override must NOT be set.

The man down timer is set in the user's permission.

At the end of the user's man down time, the Area Type Delay will activate for the set period. At the end of the Area Type Delay period the area will arm and if configured, report a man down alarm. At anytime during the man down period, authorised users with the Area Type Override set in their active profile will cancel the man down time period by disarming or disarming the area.

### Guard Tour

Guard tour is used when an authorised user(s) (such as a guard) is required to regularly "check-in" to notify others that they have physically attended to a location(s) on the site. If the authorised user(s) fails to perform this action the system can set an audible warning and report a "Guard Tour Fail" event.

The following conditions must be true before guard tour function will occur.

- a. The area type must be selected to guard tour.
- b. The area type schedule must be active (after the start time and before the end time).
- c. The user's active profile's permission must have:
  - i. This area set in the permission's guard tour group.
  - ii. The permission must be in schedule.
  - iii. The permission's Area Type Override must NOT be set.

The guard tour time is set in the user's permission.

At the end of the user's guard tour time, the Area Type Delay will activate for the set period and keypad sounder will be active. At the end of the Area Type Delay period the area will arm and if configured, report a Guard Tour Fail alarm. At anytime during the guard tour period, authorised users with the Area Type Override set in their active profile will cancel the guard tour time period by disarming or disarming the area.

## Early Open/Late Close

If the area type is Early Open & Late Close, the Auto Arm Warning sets the period after the start (opening) and the end (closing) of the area type schedule that the area must be either disarmed or armed to avoid an exception report. If the area is not disarmed (opened) within the opening window a Fail to Open message is sent. When the area is subsequently disarmed, a Late Open message is sent. If the area is not armed (closed) within the closing window a Fail to Close message is sent. When the area subsequently armed, a Late Close message is sent.

For example, if the area type schedule is set between 8:00 AM (opening time) and 5:00 PM (closing time) and the Area Type Delay is set to 15 minutes; then the area must be disarmed between 8:00 AM and 8:15 AM otherwise if it is disarmed before 8:00 AM it is an early open, if it is disarmed after 8:15 AM it is late to open. Likewise the area must be armed between 5:00 PM and 5:15 PM otherwise if it is armed before 5:00 PM it is an early close, if it is armed after 5:15 PM it is late to close.

### 7 Area Type Schedule

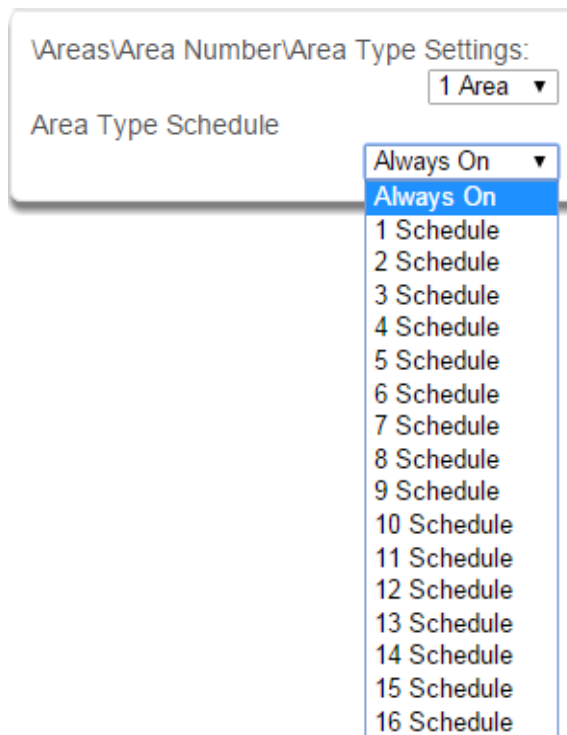

One of 96 configurable schedules can be allocated to the area type schedule. The area type schedule determines the schedule that the selected area type is active. Area types are not active when the schedule is not active. If an area type schedule is disabled (always active) that area will always have the type characteristics programmed in Area Type.

## Area Type Delay

If the area type is Standard and Arm / Disarm is configured, this timer delays arming by the minutes entered.

If the area type is Timed Disarm, Man Down, or Guard Tour, this setting is a warning time given to a user once the user's Disarm Time, Man Down Time, or Guard Tour Time has expired. During this warning time a user can cancel the automatic re-arming and event report by entering their code, this will also restart the appropriate user timer. At the end of the warning time the system will re-arm the area and send the appropriate event (closing, man down, guard tour fail).

If the area type is Early Open & Late Close, this timer sets the period after the start (opening) and after the end (closing) of the area type schedule that the area can be disarmed or armed. Otherwise an early to open or late to close report will be sent if enabled in user permissions. Fail to open and fail to close report will be sent if Arm-Disarm Reports is enabled in area options.

### Example

Area Type – Early Open & Late Close

Area Type Schedule – 8:00 to 17:00

Area Type Delay – 15 min

User Permissions – Options – Open/close report, Early open report, Late close report

Area Options – Arm-Disarm Reports

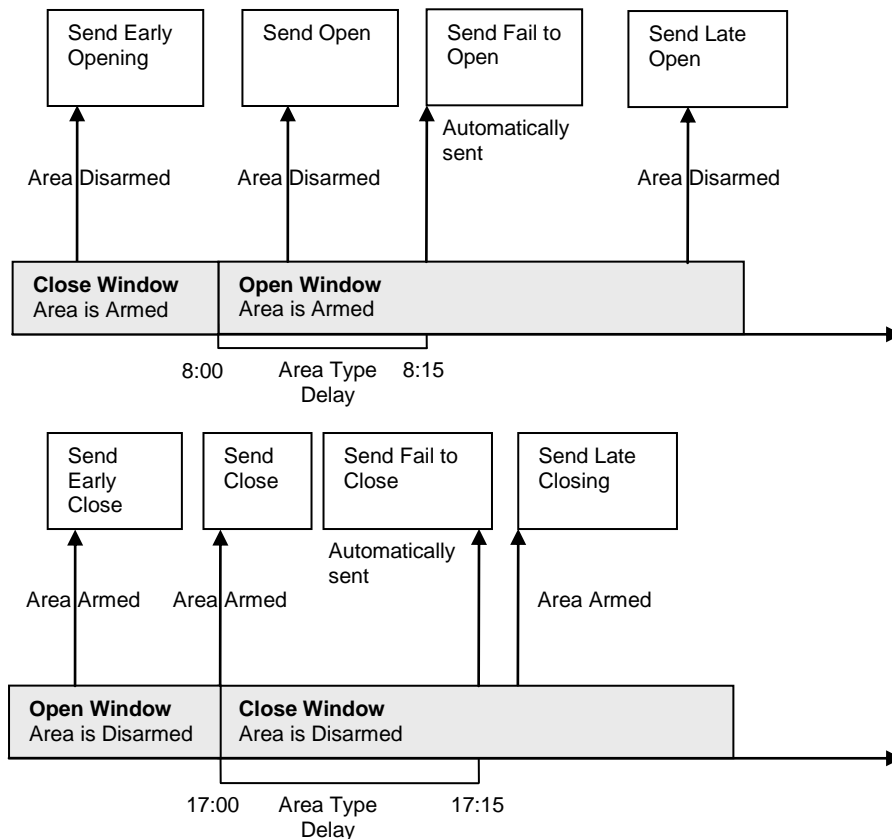

### 8 Area Event Reporting/Account

Areas\Area Number\Area Event Reporting: 1 Area ▾

Area Account

If set, the area account code is a system unique 4 to 10 digit code (format dependent) used to associate area related alarm reporting events to this area. If the area account code is equal to the default of 0, the channel account code will be used for this area's alarm reporting events. If the channel account code is equal to the default of 0, the channel 1 account code is used. If the channel 1 account code is 0 then the account will be sent as 0.

### 9 Area Event Reporting/Channels

Areas\Area Number\Area Event Reporting: 1 Area ▾

Area Channels 1 Channel Group ▾

disabled

1 Channel Group

2 Channel Group

3 Channel Group

4 Channel Group

5 Channel Group

6 Channel Group

7 Channel Group

8 Channel Group

9 Channel Group

10 Channel Group

11 Channel Group

12 Channel Group

13 Channel Group

14 Channel Group

15 Channel Group

16 Channel Group

The channel group determines which communicator channel(s) area events will be reported to. If the tick box corresponding to one of the 16 reporting channels is checked, area events will always be reported to this channel. It is referred to as a primary reporting channel. If a report is unsuccessful to a particular primary channel it will attempt that channel's backup channels if there are any.

## 6.4 Advanced Programming, Reporting and Notifications

Click the Advanced bar and select **Reporting and Notification** from the menu to program reporting and notification options.

The system can support a total of 16 channels; each channel is a communication path for events to be sent from the system to a selected destination.

Default configuration reserves Channels 1 – 3 for UltraSync format, Channels 4 – 16 are Email format.

Email is a “best-effort” system and there is no guarantee messages will be delivered by the network. When the network is busy, messages can be dropped. Central control room monitoring is highly recommended as each event is acknowledged on receipt to ensure an appropriate response can be made.

Installers have access to setup/modify all channels (1-16). Master Users have access to channels 7-16, which are used for email notifications. Standard users do not have access to channels.

R & N Sub menus

Reporting & Notifications Sub menus

**1 Channel Number**

\Reporting and Notifications\Channel Number:

1 Central Station Primary ▾

1 Central Station Primary

2 Central Station Backup 1

3 Central Station Backup 2

4 Email 1

5 Email 2

6 Email 3

7 Email 4

8 Email 5

9 Email 6

10 Email 7

11 Email 8

12 Email 9

13 Email 10

14 Email 11

15 Email 12

16 Email 13

The system can support a total of 16 channels. Each channel is identified by a unique channel number, which cannot be altered, and remains as the key reference for each channel.

Channel 1 and channels 4-16 are configured as primary reporting paths by default. Channel 1 reports to UltraSync by default. Use as Backup as the Format selection has the effect of disabling reporting of a primary channel. The Format must be selected to a value *other* than Use as Backup to enable reporting. Channels 4-16 are configured as email reporting paths by default.

**2 Channel Name**

\Reporting and Notifications\Channel Number:

1 Central Station Primary ▾

Channel Name

Central Station Primary

Custom names of the selected channel can be created here.

**3 Account Number**

\Reporting and Notifications\Channel Number:

1 Central Station Primary ▾

Account Number

0

This is the Account Number that will be reported with the event in email reports. When UltraSync format is selected, this field will not be used.

Channels 2 and 3 are configured as backup reporting paths by default. Channel 2 is set to disabled and channel 3 is set to back up channel 2 by default. Note that the primary channel must set the Next Channel for back up reporting to function.

#### 4 Format

Format is the communication format for the selected channel. Selections available in the drop down menu are shown. When Use as Backup is selected, the backup path will utilize the primary channel's format. Note that the primary channel must set the Next Channel for back up reporting to function.

**Note:** Selecting CID or SIA enables PSTN reporting. If utilizing PSTN reporting you need to enter a destination phone number. This is available in the Settings, [Channels](#) Menu.

When UltraSync is selected as the Format, the reporting path will be over the Ethernet connection. When a cellular module is installed, it will automatically act as a failover path if the Ethernet path fails. There is no requirement to configure the cellular path as a backup reporting path.

When Email is selected as the Format, the reporting will be directed to the configured email address. (Ethernet or Cellular connection required)

#### 5 Device Number

Reserved for future use

#### 6 Destination Phone/Email/Push

The destination of the notifications.

#### 7 Next Channel 1-16

If the channel selected is unable to deliver the event to the selected destination, the system will try to use this backup channel instead. The Next Channel specified here must be greater than the Channel Number.

A number lower than the current Channel Number will end the chain. This is to prevent accidental programming of endless loops.

#### 8 Event List 1-16

Select the pre-programmed list of events that will be sent via this channel. The specific events in each event list are programmed.

#### 9 Attempts

Enter the number of times the system should try to send the events to the UltraSync server. After the number of attempts has been exhausted the system will try the Next Channel if specified.

## 10 Language

\Reporting and Notifications\Channel  
Number:  
1 Central Station Primary ▾

Language

- English ▾
- English
- Français/French
- Português/Portuguese
- Español/Spanish

The reporting language used can be selected among four options.

## Configure Email Reporting

1. Login to the UltraSync Web Server or UltraSync app. Use an Installer or Master user account.
2. Press **Settings**.
3. Select Channels in the drop down menu.
4. Press **Select Channel to Configure** where the Format is already set to Email.

**Settings Selector**

Channels

Up Down Save

Select Channel to Configure:

4 Email 1

Channel Name

Email 1

Account Number

0

Format

Email

Dest Phone or Email

Next Channel

disabled

Event List

1 Event List

Attempts

2

5. Enter an email address.
6. Select an **Event List**.
7. Enter a Channel Name for future reference.
8. Press **Save**.

Installer and Master User types can customize Event Lists for selective reporting.



## 6.5 Advanced Programming, Communicator

Click the Advanced bar and select **Communicator** from the menu to program communicator options.

The system's Communicator is a core component of the system used in conjunction with the Channels feature to report events to a monitoring company or third party. In this menu you can configure the settings for various methods of reporting.

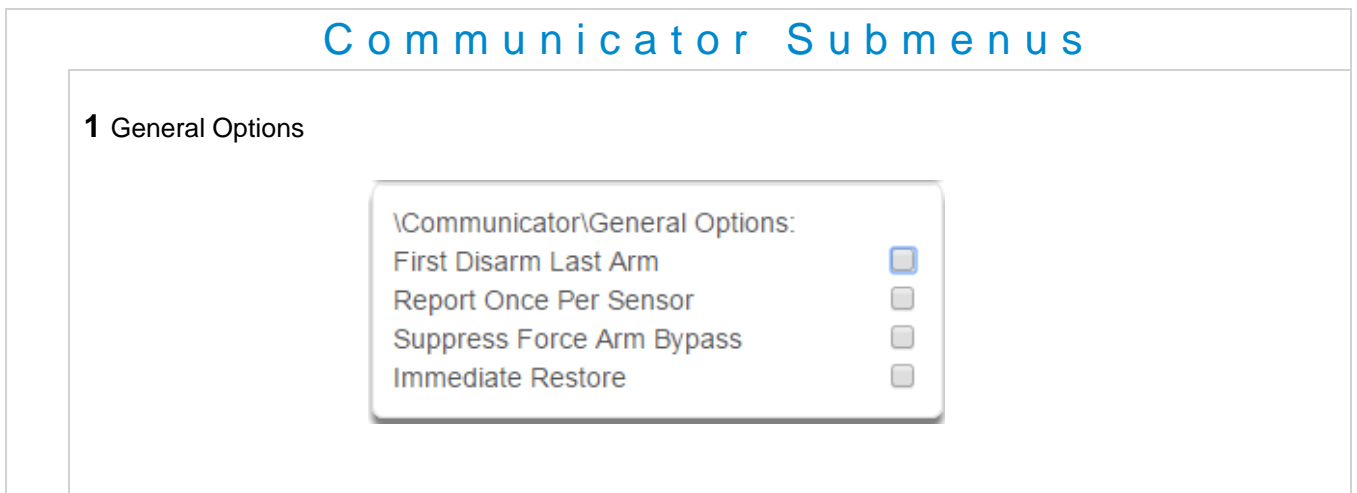
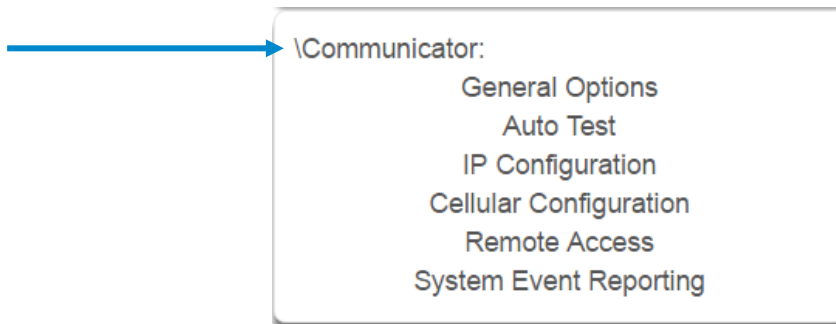

### 1. First Disarm Last Arm

If enabled, the system will only send a closing report when the last area is armed.

**Note:** The last area to arm must have open/close reports enabled. The system will only send an opening report when the first area is disarmed.

This feature is used in place of Individual area Open and close. If you enable open and close in the area you will get both individual open and close and System open close

### 2. Report Once Per Sensor

If enabled, this will limit reporting to only once per sensor each time you arm or disarm an area. This stops the control room or reporting destination to be flooded by multiple reports that the same sensor is being activated (for example the intruder may be moving around and is being picked up by the sensor on that zone).

### 3. Suppress Force Arm Bypass

If enabled, the system does not send bypass reports when a sensor is forced armed.

If not enabled, when a sensor is forced armed and it remains in a state of creating an alarm, bypass reports are sent at the end of exit time. For example this would occur if it remains open at the end of the exit time, or due to change of sensor type caused by a schedule.

If forced armed sensors re-close during the armed period, bypass restores are sent.

### 4. Immediate Restore

If enabled, the system will immediately send all restorals as the sensor reports the event.

If not enabled, the system will send restoral events all at the same time when the marea is disarmed.

### 2 Auto Test/Intervals

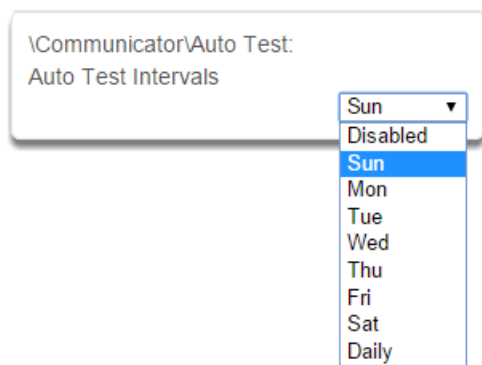

Set day of the week to send an automatic test report to the system channel group . (Communicator\System Event Reporting\System Channels). You may also set auto-test to Daily.

### 3 Auto Test/Time

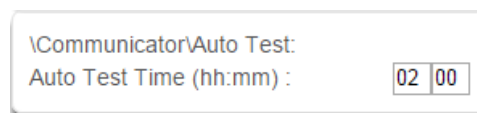

Enter the time at which the automatic test report should be sent. This should be in 24-hour format. For example 18:00.

#### 4 IP Configuration

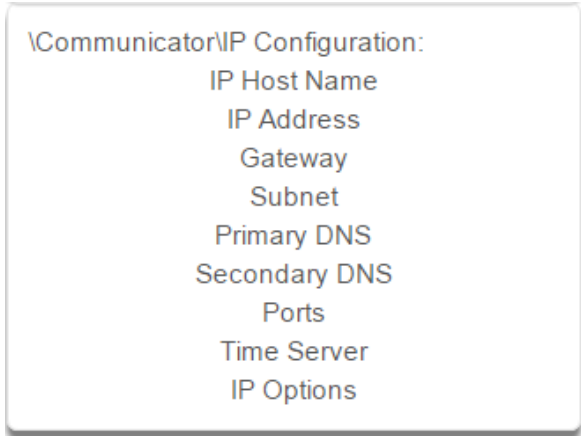

#### 5-6 IP Config Detail

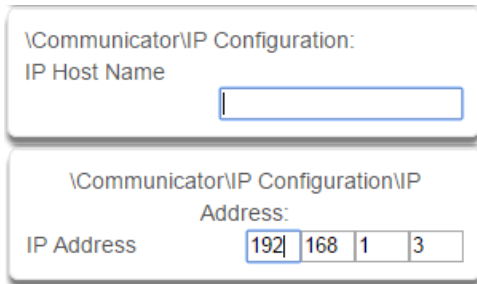

#### IP Host Name

The default IP Host Name is xgen. To access the web server without an IP address, simply type `http://xgen` into the web browser. Some browsers do not require `http://`.

To change the IP Host Name, enter a new IP Host Name and hit the Save button. The saved change does not take effect until you log out of the Web server. PCs typically cache this address for about 10 minutes. If you used the default xgen host name and then change it, the new host name will not be useable for this time frame.

**Note:** This feature is not supported with Internet Explorer. This only works on the local LAN and with a Windows® PC, or an Apple MAC. The PC or MAC must have Netbios Name Service (NBNS) enabled. It does not work remotely over the internet. Remote access to the server is supported via the UltraSync Portal.

#### IP Address

The IP address assigned to the communicator to enable it to connect on to the local LAN. This will allow you access to the embedded web server from a web-enabled device to program and view the status of the system. It is also used for alarm reporting.

#### 7-10 IP Config Detail

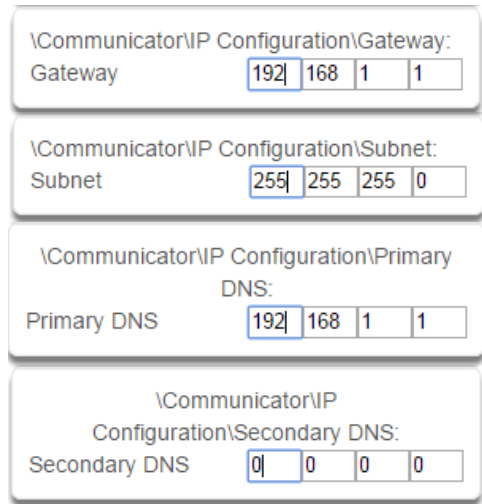

#### Gateway

If required, the IP address of the router which is needed when remote IP communications are used.

#### Subnet

The subnet mask for the network.

For example, 255.255.255.0 is the network mask for 192.168.1.0/24.

#### Primary DNS

The IP address of the Primary Domain Name Server. The DNS is used to translate host names for time servers and UltraSync servers.

#### Secondary DNS

The IP address of the Secondary Domain Name Server, used if the Primary DNS is not available.

### 11 Ports

\Communicator\IP Configuration\Ports:  
 HTTP Port   
 HTTPS Port

The ports that the computer needs to communicate with the system.

Defaults:

HTTP Port = 80  
 HTTPS Port = 443

### 12 Time Server

\Communicator\IP Configuration:  
 Time Server

Enter the URL or IP address of a time server to allow the system to automatically update and synchronise its clock without user intervention. The default is pool.ntp.org

### 13 IP Options

\Communicator\IP Configuration\IP Options:  
 Enable DHCP   
 Require SSL   
 Enable Web Updates   
 Enable Ping   
 Enable Clock Updates   
 Enable Web Program   
 Always Allow DLX900   
 Monitor LAN   
 Enable UltraConnect

**1. Enable DHCP**

Allow the system to be automatically assigned an IP address by the network.

**2. Require SSL**

Feature no longer supported. Leave unchecked.

**3. Enable Web Updates - RESERVED**

Allows the system to update the web pages via a network. Go to Hostname/mpfsupload to update the web pages served by the system. Does not update firmware.

**4. Enable Ping**

Allows the system to respond to the PING command.

**5. Enable Clock Updates**

Allows the system's internal clock to synchronise with the internet time server specified .

**6. Enable Web Program**

Enabling this option will cause UltraSync Web Server and UltraSync app to always display Installer menus regardless of if the panel is in program mode or not.

Disabling this option will hide the Installer menus on UltraSync Web Server and UltraSync app unless program mode is active. This provides greater security by keeping web programming disabled unless a user on site with physical access to the keypad enters program mode with a valid PIN code.

The system will be in program mode if a user gains authorized access to the program menu via the keypad. UltraSync app requires the Web Access Code to access to the panel.

**7. Always Allow DLX 900**

Enabling this option will allow DLX 900 to connect at any time if the correct Download Access Code is provided.

Disabling this option provides greater security by only allowing DLX 900 to connect when program mode is active. This allows the system to have DL900 access disabled until a user on site with physical access to the keypad enters program mode with a valid PIN code.

The system will be in program mode if a user gains authorized access to the program menu via the keypad.

**8. Monitor LAN**

When the Monitor LAN option is enabled the panel will monitor the Ethernet port for a valid Ethernet cable. If the Ethernet cable is disconnected while this option is enabled, and the panel is unable to communicate, it will log a Fail To Communicate event.

**9. Enable UltraSync**

This is an automatic feature. It is recommended you leave this setting on.

Enable this option to allow the system to send email reports via the UltraSync servers. This is independent of the Web Access Passcode which when set to 00000000 will prevent the UltraSync app from connecting.

If any channel is set to Email format reporting, then the system will override this setting and allow email reporting via UltraSync cloud servers.

If you wish to prevent connections to the system's cloud servers, then uncheck this option and do not use the UltraSync reporting format.

Reporting Enabled*	Web Access Passcode	Enable UltraSync	Connection to UltraSync Servers
No	00000000	No	No
No	00000000	Yes	Yes
No	non 00000000	No	Yes
No	non 00000000	Yes	Yes
Yes	00000000	No	Yes
Yes	00000000	Yes	Yes
Yes	non 00000000	No	Yes
Yes	non 00000000	Yes	Yes

\* Includes email and UltraSync reporting for all channels

**17 Cellular Configuration**

\Communicator\Cellular Configuration:  
 Username (optional)  
 Password (optional)  
 APN (optional)

**19 Password (optional)**

\Communicator\Cellular Configuration:  
 Password (optional)  
 \*\*\*\*\*

Optional password for APN. This is normally not used unless a non-standard cellular SIM is utilized

**21 Remote Access**

\Communicator\Remote Access:  
 Panel Device Number  
 Download Access Code  
 Call Back Number  
 Callback Server  
 Number Of Rings  
 Number of Calls  
 Answering Machine Defeat  
 Download Options

**22 Panel Device Number**

\Communicator\Remote Access:  
 Panel Device Number  
 0

A number from 0 to 4,294,967,295 that must be entered in to the desktop software for remote access to take place.

**18 Username (optional)**

\Communicator\Cellular Configuration:  
 Username (optional)

Optional username for APN. This is normally not used unless a non-standard cellular SIM is utilized.

**20 APN (optional)**

\Communicator\Cellular Configuration:  
 APN (optional)

Optional Access Point Name (APN) for the gateway between the cellular network and the public Internet. This is normally not used unless a non-standard cellular SIM is utilized.

**23 Download Access Code**

\Communicator\Remote Access:  
 Download Access Code  
 00000000

This is a variable length code for the computer user. This code gives the DLX 900 software complete authority over all menus including those that are locked. For convenience DLX 900 will also try **installer** and **9-7-1-3** to allow a connection for first time set up if the Download Access Code does not work. This is why changing the default installer PIN code is important.

Changing this code may lock out your control room monitoring service and prevent you from maintaining your system. It is advised you contact your control room before changing this code.

Users must have access to the Communicator menu in order to change this setting. This can be programmed in Menus, and assigning the "Advanced" menu.

### 24 Call Back Number

\Communicator\Remote Access\Call Back Number:  
Call Back Number [0-9#\*P]

If a telephone number is programmed into this feature, and “Call Back Before Download” is enabled, the system will disconnect for approximately 10 seconds and then call this number.

The system does not support pulse dialling. A one second pause is entered by using a P.

**IMPORTANT:** the call back phone number should always be reviewed for accuracy before disconnecting!

### 26 Number of Rings

\Communicator\Remote Access:  
Number Of Rings

This contains the number of rings the panel must detect before answering the telephone line when initiating a download session. Answering machine defeat does not need to be enabled.

A value of 1 to 15 can be entered in this segment. If this ring count is reached on any individual call, the panel will answer regardless of the call count or number of calls programming.

Default = 8

### 28 Answering Machine Defeat

\Communicator\Remote Access:  
Answering Machine Defeat

Answering Machine Defeat: Answering machines usually answer calls after a long ring period. The Answering Machine Defeat feature prevents the answering machine from answering the call from the software by making only short rings. If enabled, the system will always answer the call on the second call back. This option is independent of Number of Calls and Number of Rings.

### 25 Callback Server

\Communicator\Remote Access:  
Callback Server

If an IP address or host name is programmed into this feature, and “Call Back Before Download Session” is enabled, the system will disconnect for approximately 10 seconds and then connect to this IP address.

This should be the IP address of the computer where DLX 900 is installed, not the IP address of the system.

**IMPORTANT:** the call back IP address should always be reviewed for accuracy before disconnecting.

### 27 Number of Calls

\Communicator\Remote Access:  
Number of Calls

This contains the number of calls the panel must detect before answering the telephone line when initiating a download session. Answering machine defeat does not need to be enabled.

A value of 1 to 15 can be entered in this segment. A call is satisfied by one (1) or more rings, and then an eight (8) second period of no ringing. The next call must then be made within 45 seconds.

This location stands alone. If it still needed Number of Rings it could be blocked by an answering machine. This will answer on the first ring if the call count is reached.

For example: If number of calls is set to 3. And you call the premises and hang up after any number of rings, wait at least 8 seconds, call again and hang up after any number of rings, wait at least 8 seconds, and call again (this is the third call) the panel will answer on the third ring because the call count has reached the Number of Calls programmed value.

If on any individual call the number of rings on that call is reached, the panel will answer on that call regardless of the call count.

Default = 0, system will pick up the call immediately.

**29** Download Options

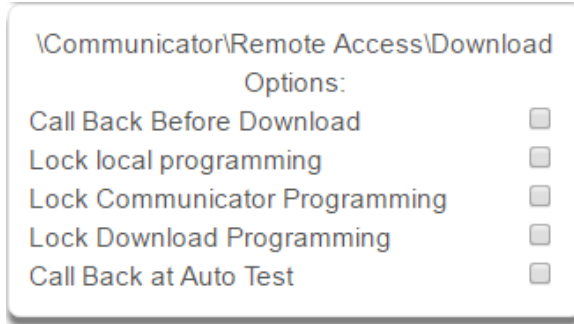

**1. Call Back Before Download**

If a download is requested the system will hang up and make a call to the Call Back Number. This is to increase the security of remote access.

**2. Lock local Programming**

Prevents changes to the system system via a keypad. All changes **MUST** be made using the remote access software. This requires Download Access Code to be enabled.

**3. Lock Communicator Programming**

Prevents local programming of communicator features unless accessed by the Download Access Code. This restricts programming of the communicator.

**4. Lock Download Programming**

Prevents the local programming of the Remote Access Menu without using the Download Access Code.

**5. Call Back at Auto Test**

When an auto test is initiated, perform a Call Back Server or Call Back Number to the number specified.

**30** Event Reporting /Channels

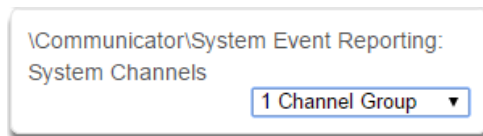

Enter the Channel Group that the system will send system events to.

**Example**

If Channel 1 is the primary, and Channel 2 is the backup for Channel 1, then when both channels fail it will go back to Channel 1. This setting controls how many times the system cycles back to Channel 1 before it gives up.

The Channel Attempts setting controls how many times the system stays on the channel before switching to the backup.

Always check the max. number of attempts on all channels to avoid unexpectedly high communication charges.

**31** Event Reporting /Attempts

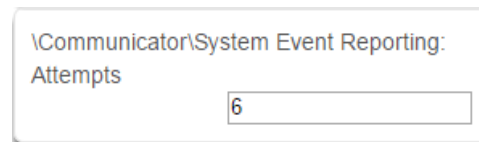

This is the number of times the system will sequence back to the primary channel if the backup channels all fail. This applies to ALL communication attempts including sensor and area events.



In the diagram below, the system will try Channel 1 3 times, switch to Channel 2 and try 2 times, then go back to Channel 1. This sequence is repeated 2 times in total. In total there will be 10 attempts.

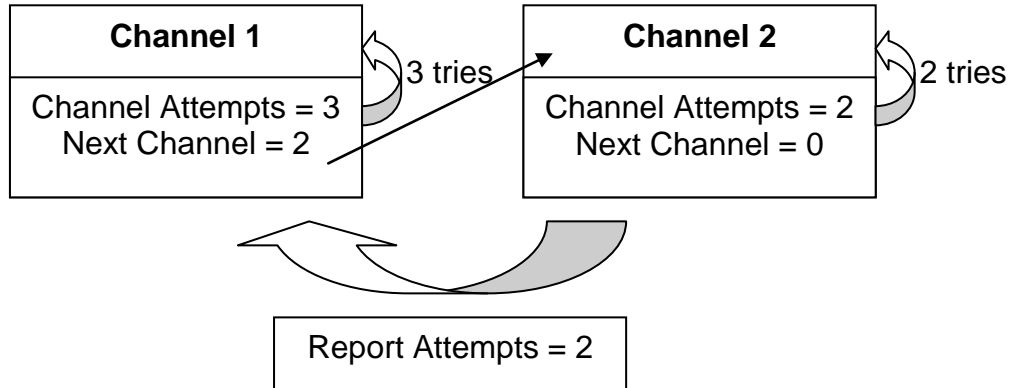

## 6.6 Advanced Programming, Schedules

Click the Advanced bar and select **Schedules** from the menu to program schedule options.

### Schedules Submenus

#### 1 Schedule Number

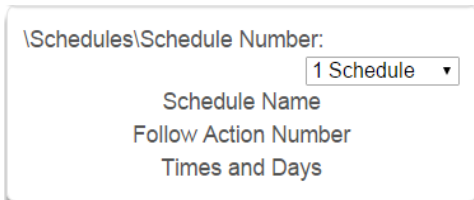

The system can support a total of 96 schedules. Each schedule is identified by a unique schedule number, which cannot be altered, and remains as the key reference for each schedule.

#### 2 Schedule Name

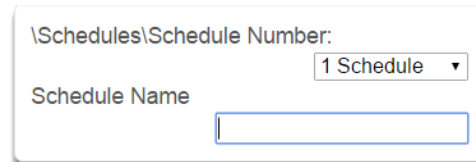

Each schedule can be configured with a custom 32 character name. The area name is displayed wherever a schedule is referenced on the system.

#### 3 Follow Action Number

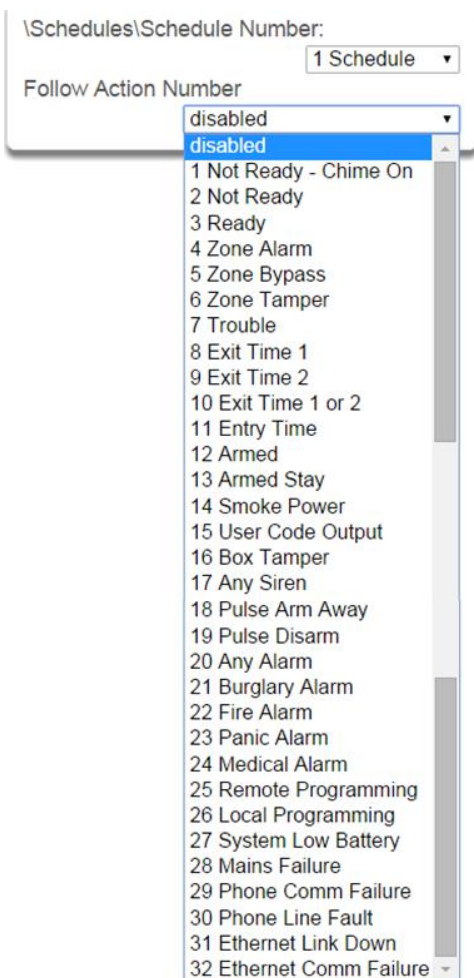

If an action number is specified, then the schedule becomes enabled when the action is true. When the action becomes false, then the schedule becomes disabled.

Schedules can be used to control various parts of the system such as when a user's permissions are applied. The "Follow Action Number" option allows you to use actions to control schedules.

The result is actions can control when permissions are applied, when area types are applied, sensor behaviors, when arm-disarm can occur, and when scenes play.

This allows you to create conditional schedules that only become active when certain conditions are met. For example you could create a user that only becomes active (because of the linked schedule) under certain conditions like a fire alarm.

## Follow Action

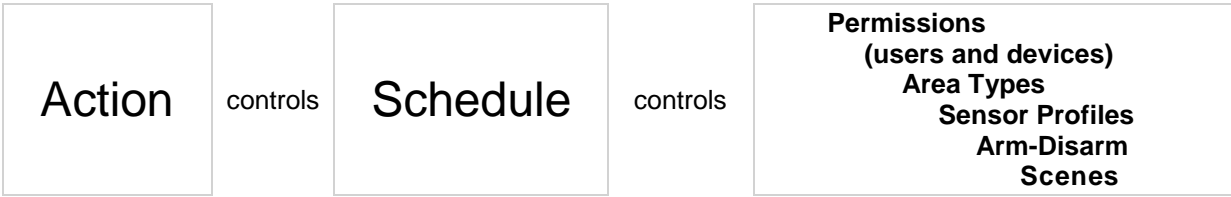

### 4 Times and Days

\Schedules\Schedule Number\Times and Days\Time and Day Number:

1 Schedule ▾

1 Time and Day Number ▾

Start Time

End Time

Days

Up to 16 sets of time and days can be specified here.

### 5 Start Time / End Time

\Schedules\Schedule Number\Times and Days\Time and Day Number:

1 Schedule ▾

1 Time and Day Number ▾

Start Time (hh:mm) :      00 | 00

\Schedules\Schedule Number\Times and Days\Time and Day Number:

1 Schedule ▾

1 Time and Day Number ▾

End Time (hh:mm) :      00 | 00

### 6 Days / Holidays

\Schedules\Schedule Number\Times and Days\Time and Day Number\Days:

1 Schedule ▾

1 Time and Day Number ▾

All Days

All Weekdays

All Weekend

Monday

Tuesday

Wednesday

Thursday

Friday

Saturday

Sunday

Holidays 1

Holidays 2

Holidays 3

Holidays 4

The system handles schedules that span midnight automatically. For example, if a schedule is to cover Fri 8:00pm to Sat 6:00am, *only check Friday* and the system will automatically manage the time after midnight.

Thu	Fri ✓	Sat	Sun
		—	

If you *check Friday and Saturday*, the schedule will cover Fri 8:00pm – Sat 6:00am and Sat 8:00pm – Sun 6:00am.

Thu	Fri ✓	Sat ✓	Sun
		—	—

**Note:** Holidays 1-4: If checked, it means the item assigned this schedule will NOT have access during the specified holiday dates.

See [Advanced Programming, Holidays](#) to program these dates.

## 6.7 Advanced Programming, Actions

The system features powerful automation control which can interact with different parts of the system. It can perform functions based on the status of one or more system conditions.

These features are considered advanced programming and should only be changed by an installer with a thorough understanding of the features.

Each action has an **on** and **off** state. The state is controlled by up to 4 conditions called Action Events, each of which can have a range of items:

Action Event Sequence										
<b>Event 1</b>	and or	<b>Event 2</b>	and or	<b>Event 3</b>	and or	<b>Event 4</b>	=	<b>Action State (trigger)</b>	+	<b>Action Result</b>

When all 4 Action Events are met, then the Action State (trigger) will be set. The Action State can be monitored by the system, Schedules, Devices with outputs, and Scenes to activate/deactivate.

For example, a strobe connected to Output 2 can be programmed to follow Areas 1 – 8 being armed.

Strobe Action Sequence				
<b>Areas 1 – 8 All Armed</b>	=	<b>Action 1 True</b>	+	<b>Activate Strobe</b>

Each Action can also directly control selected parts of your system when all 4 Action Events are met. This is called the Action Result. Its behavior also follows the Action State.

For example, when all areas are armed and there is activity on Sensor 1, activate a camera recording.

Camera Action Sequence				
<b>Areas 1 – 8 Armed</b> and <b>Sensor 1 Faulted</b>	=	<b>Action 1 True</b>	+	<b>Activate Camera</b>

Click the Advanced bar and select **Actions** from the menu to program actions options.

Actions\Action Number:  
 ▾  
 Action Name  
 Function  
 Duration Minutes  
 Duration Seconds  
 Event 1  
 Event 2  
 Event 3  
 Event 4  
 Result

## Actions Submenus

### 1 Action Number

Actions\Action Number:  
 ▾  
 Function  
 ▾

- 1 Not Ready - Chime On
- 2 Not Ready
- 3 Ready
- 4 Zone Alarm
- 5 Zone Bypass
- 6 Zone Tamper
- 7 Trouble
- 8 Exit Time 1
- 9 Exit Time 2
- 10 Exit Time 1 or 2
- 11 Entry Time
- 12 Armed
- 13 Armed Stay
- 14 Smoke Power
- 15 User Code Output
- 16 Box Tamper
- 17 Any Siren
- 18 Pulse Arm Away
- 19 Pulse Disarm
- 20 Any Alarm
- 21 Burglary Alarm
- 22 Fire Alarm
- 23 Panic Alarm
- 24 Medical Alarm
- 25 Remote Programming
- 26 Local Programming
- 27 System Low Battery
- 28 Mains Failure
- 29 Phone Comm Failure
- 30 Phone Line Fault
- 31 Ethernet Link Down
- 32 Ethernet Comm Failure

### 2 Action Name

Actions\Action Number:  
 ▾  
 Action Name

Each Action can be configured with a custom 32 character name. The name is displayed wherever an Action is referenced on the system.

### 3 Function

Actions\Action Number:  
 ▾  
 Function  
 ▾

- Disabled
- Timed
- Follow
- On Delay
- Off Delay
- Pulsed
- Latch
- Manual Control

- Timed – The action state turns **on** for the time specified.
- **Follow** (Recommended) – The action state turns **on** once the Event conditions have been satisfied, then **off** once the Event conditions are not true.
- On Delay – The action state becomes **on** after the programmed time period unless the logic result is no longer active.
- Off Delay – Follows the result of the logic equation, but remains active for the time programmed after the logic result is no longer active.
- On Pulse – Action state turns **on** for the programmed time or the active period of the logic result, whichever is the SHORTEST.
- Latch – The action state stays **on** once the Event conditions have been satisfied.

The system can support a total of 256 Actions. Each Action is identified by a unique number, which cannot be altered, and remains as the key reference for each Action.

Note: All actions are pre-programmed with the specified trigger. To create a new action, you need to modify one of these actions.

#### 4 Duration: Minutes

Actions\Action Number\Duration Minutes:  
 1 Not Ready - Chime On ▾  
 Duration Minutes [0-65535]  
 0

Where the Function requires duration, this determines, in minutes, how long the action should stay on.

#### 5 Duration: Seconds

Actions\Action Number\Duration Seconds:  
 1 Not Ready - Chime On ▾  
 Duration Seconds [0-65535]  
 0

Where the Function requires duration, this determines, in seconds, how long the action should stay on.

#### 6 Event(s) 1-4 and Results

Actions\Action Number:  
 1 Not Ready - Chime On ▾  
 Action Name  
 Function  
 Duration Minutes  
 Duration Seconds  
 {  
 Event 1  
 Event 2  
 Event 3  
 Event 4  
 }  
 Result

#### 7 Event Attributes

Actions\Action Number\Event 1:  
 1 Not Ready - Chime On ▾  
 {  
 Event Category  
 Event Type  
 Event Start Range  
 Event End Range  
 Combination Logic  
 }

#### 8 Event Category

Actions\Action Number\Event 1:  
 1 Not Ready To Arm ▾  
 Event Category  
 Sensor Events ▾  
 Sensor Events  
 Area Events  
 User Events  
 Logic State  
 Schedule States  
 Device Status  
 System Events

Select the category of the first event. This will determine what events you can select in Event Type.

See the [Action Events Category](#) and Action Event Types table in Section A.10 for reference.

#### 9 Event Type

Actions\Action Number\Event 1:  
 1 Not Ready - Chime On ▾  
 Event Type  
 disabled ▾  
 disabled  
 Faulted  
 Not Faulted  
 Alarm  
 Bypass  
 Tamper  
 Low Battery  
 Trouble  
 Supervision  
 Chime Enabled  
 Inhibited  
 Alarm Memory  
 Test  
 Test Fail

Select the event that you want the Action to monitor.

See the [Action Events Category](#) and Action Event Types table in Section A.10 for reference.

### 10 Event Start Range

Actions\Action Number\Event 1:  
 1 Not Ready - Chime On ▾  
 Event Start Range

Select the starting number of the event that you want the Action to monitor. This is related to a number range. For example this might be the first area or sensor number.

### 11 Event End Range

Actions\Action Number\Event 1:  
 1 Not Ready - Chime On ▾  
 Event End Range

Select the ending number of the event that you want the Action to monitor. This is related to a number range. For example this might be the last area or sensor number.

If you just want to monitor one item, then leave it at the default of zero, or enter the same number as Event Start Range.

### 12 Event Combination Logic

Actions\Action Number\Event 1:  
 1 Not Ready - Chime On ▾  
 Combination Logic  
 OR ▾  
 OR  
 Inverted OR  
 AND  
 Inverted AND  
 RESET

The logic condition to apply to Event 1

- OR e.g. Area 1 Armed Away **OR** Area 2 Armed Away
- Inverted OR e.g. **NOT** Sensor 1 Bypass **OR** Sensor 2 Bypass
- AND e.g. Area 1 Armed Away **AND** Area 2 Armed Away
- Inverted AND e.g. **NOT** Sensor 1 Bypass **AND** Sensor 2 Bypass
- RESET Reset any latched event

The Combination Logic selected for each event places the logic prior to the event in an equation. Selecting the AND logic closes a parenthesis for the previous event. The DLX 900 software displays an Event Equation field to make it easier to construct Actions.

For example:

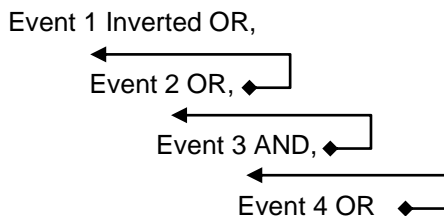

produces a logic equation of:  
**(NOT Event 1 OR Event 2) AND (Event 3 OR Event 4)**

### 13 Result

Actions\Action Number:  
 ▾  
 Action Name  
 Function  
 Duration Minutes  
 Duration Seconds  
 Event 1  
 Event 2  
 Event 3  
 Event 4  
 Result

The system can also perform an additional function once the Action Event conditions are satisfied. This is called an Action Result.

For example, when a fire alarm is active, you could disable Users 1-50 to prevent them from being able to control the alarm system.

### 15 Result Type

Actions\Action Number\Result:  
 ▾  
 Result Type  
 ▾  
 disabled  
 Zone Trip Toggle  
 Zone Trip  
 Zone Restore  
 Zone Bypass Toggle  
 Zone Bypass  
 Zone Unbypass  
 Zone Chime Toggle  
 Zone Chime On  
 Zone Chime Off  
 Zone Walk Test Toggle  
 Zone Walk test On  
 Zone Walk Test Off

The event of the Action Result to perform  
 See the [Action Results Category](#) and Action Results Event Types table in Section A.11 for reference.

### 17 Result End Range

Actions\Action Number\Result:  
 ▾  
 Result End Range

Select the ending number of the event that you want the Action Result to affect.

### 14 Result Category

Actions\Action Number\Result:  
 ▾  
 Result Category  
 ▾  
 Sensor Results  
 Area Results  
 User Results  
 System Results  
 Device Results  
 Scene Result  
 Camera Result

Result Category: The category of the Action Result to perform.

See the [Action Results Category](#) and Action Results Event Types table in Section A.11 for reference.

### 16 Result Start Range

Actions\Action Number\Result:  
 ▾  
 Result Start Range

Select the starting number of the event that you want the Action Result to affect.

### 18 Result User Number

Actions\Action Number\Result:  
 ▾  
 Result User Number

Select the User that you want the Action Result to behave as. This will apply this user's full permissions to the Action Result you select.



## 6.8 Advanced Programming, Auto Arm-Disarm

Advanced Arm-Disarm programming allows the system to automate arming and disarming according to a specified schedule.

Click the Advanced bar and select **Arm-Disarm** from the menu to program arm-disarm options.

Auto Arm-Disarm\Arm-Disarm Number: 1 Arm-Disarm ▼

Name  
User Number  
Schedule Number

### Arm - Disarm Submenus

#### 1 Name

Auto Arm-Disarm\Arm-Disarm Number: 1 Arm-Disarm ▼

Name

Each scenario can be configured with a custom 32 character name. The name is displayed wherever an Arm-Disarm scenario is referenced on the system.

#### 2 User Number

Auto Arm-Disarm\Arm-Disarm Number: 1 Arm-Disarm ▼

User Number

The user number that will perform the Arm-Disarm. The user's schedule and permissions will be checked and applied to all areas in the user's arm or disarm area group at the time of the Arm-Disarm.

#### 3 Schedule Number

Auto Arm-Disarm\Arm-Disarm Number: 1 Arm-Disarm ▼

Schedule Number Always On ▼

The system can support a total of 32 automated Arm-Disarm scenarios. Each scenario is identified by a unique number, which cannot be altered, and remains as the key reference for each function.

The schedule number specified here determines when the arm and disarm is performed by the user number. The starting date/time of the schedule will perform a disarm, the ending date/time of the schedule will arm

Arm - Disarm Submenus

When a Schedule becomes valid (inside valid time sensor) the system will disarm all Areas that are in the User's - Active Profile - Disarm Area Group. When the Schedule becomes invalid (out of time sensor) then the system will arm all areas that are in the User's - Active Profile - Arm Area Group.

For example if we had Schedule 4 Mon-Fri 9am-5pm, and User 55 with permission to arm and disarm area 1, 2, and 3, plus their schedule was 24 hours 7 days a week.

Then each weekday at 9am the system would disarm areas 1, 2, and 3 as if it were user 55. At 5pm each weekday the system would arm areas 1, 2, and 3 as if it were user 55.

Arm Disarm Number 1 – Arm-Disarm Example

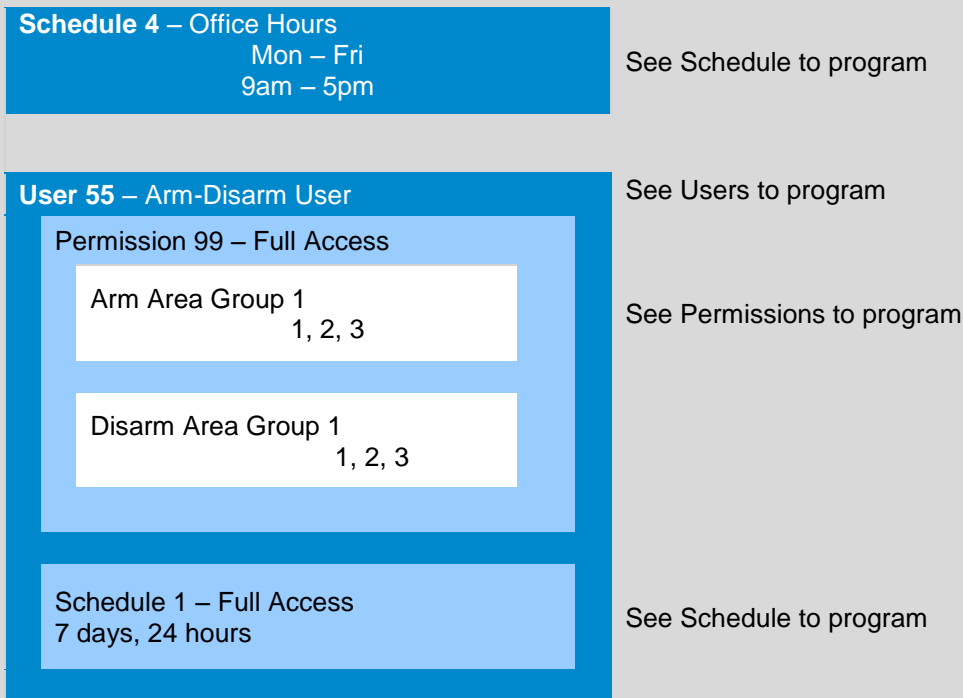

For an Arm-Disarm to occur, both the Arm-Disarm schedule here and the User Schedule need to be valid at the time the Arm-Disarm is triggered.

The Arm-Disarm Schedule determines what the operation is. The leading edge causes a disarming function and trailing edge causes an arming function. The Users Permissions then determines which areas if any are armed or disarmed. If the function is to disarm, the Users Disarm Area Groups will be disarmed. If the function is to arm, the Users Arm Area Group will be armed.

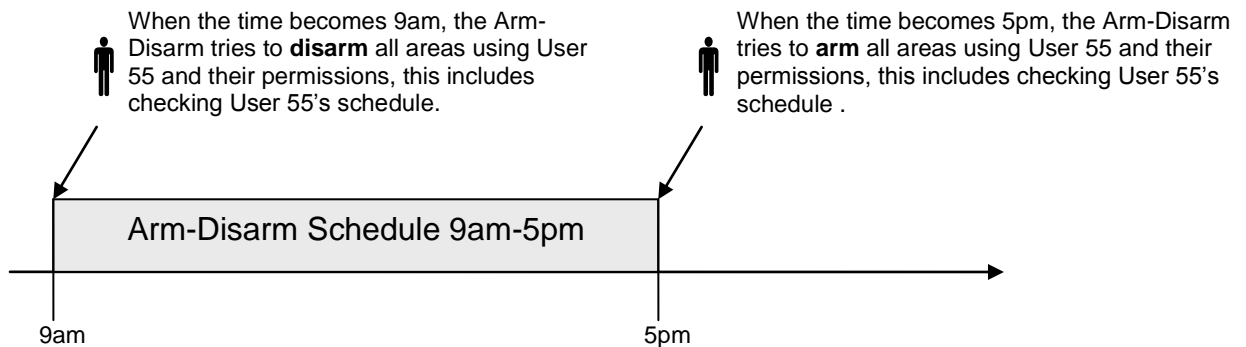

More complex interactions with the system are possible by modifying the schedule selected here, the schedule assigned to the user, and even combining actions to control schedules. Also, user permissions can have up to 4 permission and schedule pairs.

## 6.9 Advanced Programming, Devices and Enrollment

Click the Advanced bar and select **Devices** from the menu to program device options.

This menu allows you to program devices connected to the system.

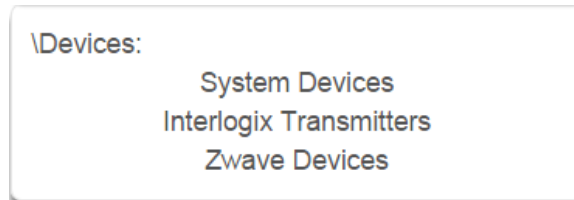

### 6.9.1 System Devices

Select System Devices to program and enroll devices including CPU (Control), keypads, zone expansion modules, relay expansion modules and smart power supplies.

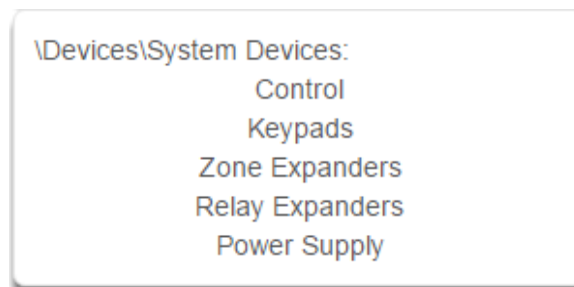

### 6.9.1.1 Control Devices

Control Devices are currently limited to the CPU. Use this section to view the CPU serial number, configure the name and view device information such as firmware and hardware revisions. You can also program the 5 on-board CPU outputs, perform enrollment functions and view the current system device counts.

Devices Submenus

**1 System Devices Control**

\Devices\System Devices:

- Control
- Keypads
- Zone Expanders
- Relay Expanders
- Power Supplies

Select Control.

**2 System Devices Control Device Number**

\Devices\System Devices\Control\Device

Number: 1 Control ▾

Device Unique ID (UID) 1 Control

Control Name 2 Control

Control Info

Control Output 1

Control Output 2

Control Output 3

Control Output 4

Control Output 5

Enroll Function

Enroll State

Device Count

Select among control devices to program them.

**3 Device UID**

\Devices\System Devices\Control\Device

Number: 1 Control ▾

Device Unique ID (UID)

741299454728

Serial number of the CPU.

**4 Control Name**

\Devices\System Devices\Control\Device

Number: 1 Control ▾

Control Name

Alarm System

The name of the system.

Devices, Control

## 5 Control Info

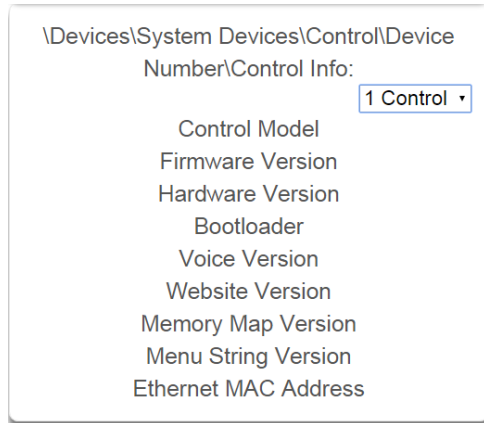

Version information about the system including firmware, voice, web, and MAC address.

## 6 Control Output 1

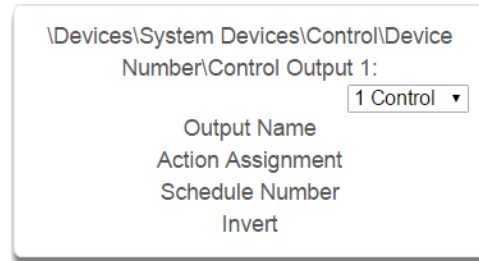

The system has 5 on-board control outputs. While some are defaulted to drive specific outputs, all of them are programmable via actions. See the following section detailing each control output.

### 6.9.1.1.1 Control Outputs

#### Control Output 1 – on terminal J7

Three modes of operation:

1. Defaulted as a siren driver that follows an alarm (DC output).
  - 1a) Terminal OP1+SR supplies 13.8 VDC.
  - 1b) Terminal OP1-SR provides ground when activated (via alarm or action).
  - 1c) This is an open circuit when not activated
2. Configurable for speaker driver that follows alarm (sinusoidal output).
  - 2a) Advanced\System\Siren Options: “Voltage Siren Output”
    - Off = speaker
    - On = DC siren
3. Configurable as programmable output via actions.
 

This line is supervised only if set up as a speaker or DC siren output. Supervision does *not* require an EOL resistor when a speaker is connected. Line is not supervised if configured as output via Actions.

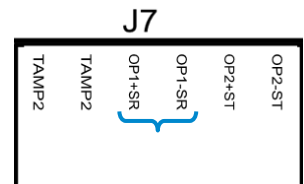

An external tamper input (Tamp2) is available on the terminal strip to support an external enclosure. To enable this option, go to:

**Advanced – System – Siren Options – Siren Box Tamper** ([View page](#))

Speakers: 15 or 30 watts

Speaker current draw for allowed Ohm rating, typical:

4Ω	–	490 mA	(max load, do not exceed this current draw)
8Ω	–	230 mA	“
16Ω	–	138 mA	“

**Note:** Current draw must be accounted for in your power budget calculations.

#### Control Output 2 – on terminal J7

Two modes of operation:

1. Default operates as a Strobe driver that follows alarm (DC output only).
 

Timing configured in **Advanced – System Timers – Strobe Time** ([View Page](#))
2. Configurable as programmable output via actions.

Terminal OP2+ST supplies 13.8 VDC.

Terminal OP2-ST provides ground when activated (via alarm or action).

This is an open circuit when not activated.

**Note:** Current draw must be accounted for in your power budget calculations.

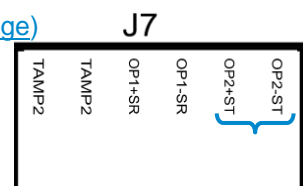

**Control Output 3 – on terminal J10**

Two modes of operation:

1. Default operates as a Piezo driver that follows alarm (DC output only).  
Configurable for DC Siren that follows alarm (DC output, same as Output 1).  
No option for Speaker operation.
2. Configurable as programmable output via actions.

POS terminal on J10 supplying 13.8 VDC is shared with output 4.  
OP3- provides ground when activated (via alarm or action).

**Note:** Current draw must be accounted for in your power budget calculations.

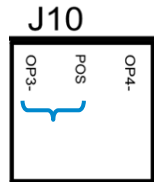

**Control Output 4 – on terminal J10**

Disabled by default.

Three modes of operation:

1. For 2-wire smoke detectors, mark the check box to enable in:  
**Advanced – System – General Options** ([View page](#))  
Configure Sensor 8 Type as Fire Alarm  
Configure Sensor 8 Sensor Options as Fire  
**Note:** The system uses Zone 8 for two wire smoke. Zone 8 will be unavailable for use.  
Limit of xx smoke detectors, future content  
**Note:** Current draw must be accounted for in your power budget calculations.

2. For 4-wire smoke detectors, enable in:  
**Advanced – Devices – System Devices – Control** ([View page](#))  
Select **Control Output 4** to program  
Select **Action Assignment**  
Select **Action 14, Smoke Power** in drop down menu ([View page](#))  
Set output to invert  
Wire detectors to any zone.  
Configure Sensor Type as Fire Alarm  
Configure Sensor Sensor Options as Fire

The number of smoke detectors is limited by the capacity of the system’s power supply. Multiple outputs can be used to increase the detector capacity.

**Note:** Current draw must be accounted for in your power budget calculations.

3. Configurable as programmable output via actions.

POS terminal on J10 supplying 13.8 VDC is shared with output 3.  
OP4- provides ground when activated (via alarm or action).

**Note:** Current draw must be accounted for in your power budget calculations.

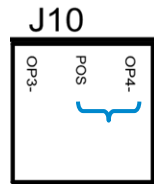

**Control Output 5 – on terminal J19**

Disabled by default.

Programmable via **Actions** only.  
Shared terminal with COM for zones 7 and 8.  
If utilized for output Zone 7 and 8 must be wired to *separate* COM terminal.  
POS terminal on J19 supplies 13.8 VDC.

**Note:** Current draw must be accounted for in your power budget calculations.

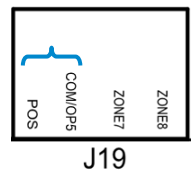

**7 Control Output, Output Name**

\Devices\System Devices\Control\Device  
Number\Control Output 1:

Output Name 1 Control ▾

Each output can be configured with a custom 32 character name.

**8 Control Output, Action Assignment**

\Devices\System Devices\Control\Device  
Number\Control Output 1\Action  
Assignment: 1 Control ▾

Action

disabled ▾

disabled

1 Not Ready - Chime On

2 Not Ready

3 Ready

4 Zone Alarm

5 Zone Bypass

6 Zone Tamper

7 Trouble

8 Exit Time 1

9 Exit Time 2

10 Exit Time 1 or 2

11 Entry Time

12 Armed

13 Armed Stay

14 Smoke Power

15 User Code Output

16 Box Tamper

17 Any Siren

18 Pulse Arm Away

19 Pulse Disarm

The output will activate while the selected action state is true. If the action state becomes false then the output will deactivate.

**9 Control Output, Schedule Number**

\Devices\System Devices\Control\Device  
Number\Control Output 1:

Schedule Number 1 Control ▾

Always On ▾

If a schedule is entered here then the output will only be active when the schedule is valid. If no schedule is entered then the output will always function.

**10 Control Output, Invert**

\Devices\System Devices\Control\Device  
Number\Control Output 1:

Invert 1 Control ▾

Invert the Output (normally not used)

### 6.9.1.1.2 Enrollment

#### 11 Enroll Function

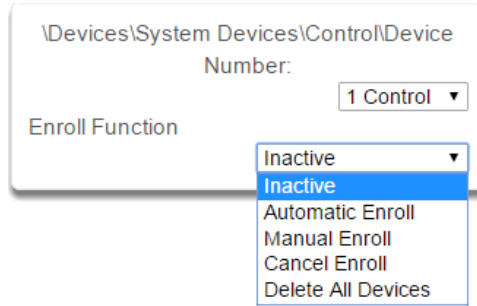

This menu allows you to add new devices to the system.

**Inactive** means no enrollment is active on the system.

**Automatic Enroll** (Automatic enrollment can also be initiated by pressing the Enroll button on the CPU) This is recommended in two scenarios: Either 1) when you are first setting up your system or 2) when enrolling one device only. The procedure automatically searches the bus for new connected devices and adds them to the system in this way:

- 1<sup>st</sup>: By first open (available) slot or “position”.  
This becomes the device number.
- 2<sup>nd</sup>: In order of Unit ID.

Example: Add 3 zone expansion modules to a new system.

Open slot #	Unit ID #
1	0101 1234
2	0101 1235
3	0102 1234

Unit ID numbers are in numerical order in the first open slots 1-3.

Later add 1 more module to your system. The next available slot is (4). Notice that the device in slot 4 has a lower serial number than those in slots 1-3. But it is in order by available slot, which is prioritized over Unit ID.

Open slot #	Unit ID #
4	0100 1234

Alternatively, you may automatically enroll connected devices by holding down the [S1 button](#) on the main panel for 3 seconds. The S1 LED (D5) will blink slowly to indicate automatic enrollment is in progress. Confirmation messages also appear on the keypad. When the LED stops flashing then the enrollment function has finished.

The system also assigns each device its correct device type. Example system with multiple devices:

	Control Devices	Keypads	Zone Expanders	Relay Expanders
Device #	1	1	1	1
Device #		2	2	2
Device #			3	



## Manual Enrollment

**Option 1:** Select **Manual Enroll** from the drop down menu. Then click **Save**. This puts system into manual enrollment mode and waits for you to push the ENROLL button on the Expansion Module/device you want to enroll. The benefit of manual enrollment is that you can control the sequence and device numbering during enrollment. Simply push the Enroll button on the device to be enrolled after the Manual Enroll mode has been enabled on the CPU.

### Option 2:

This option requires the user manually enter the device Unit ID into the server. Go to:

**Advanced – Devices – System Devices** ([View page](#))

Select the type of device you are enrolling: (Keypad – Zone Expander – Relay Expander)

Select the next available device number.

Click device UID.

Enter the device Unit ID in the form field and click **Save**.

The device is now enrolled in the system.

---

**Note:** You have 5 minutes to manually enroll devices before the system exits back into normal mode. When the manual enrollment function is running, the bus will be disabled and no feature that requires access to the main panel will work. This includes arming or disarming of areas.

---

**Note:** You can change the device number using the management software, DLX 900

---

**Cancel Enroll** will stop the manual enrollment mode when you click **Save**.

## Replacing Devices

In the event of a physical device failure, a new device can be added to the system without the need to enroll and reprogram the device settings.

To replace a system device go to:

**Advanced – Devices – System Devices**

Select the type of device you are deleting: (Keypad – Zone Expander – Relay Expander)

Select the device number of the device you are replacing.

Click Device Unique ID (UID).

Enter the new device's UID that is printed on the product label into the form field and click **Save**.

## Deleting Devices

**Delete All Devices** removes all expansion modules/devices from the system bus when you click Save.

### Manually Delete Individual Devices

To manually delete system devices go to:

**Advanced – Devices – System Devices**

Select the type of device you are deleting: (Keypad – Zone Expander – Relay Expander)

Select the device number of the device you are deleting.

Click Device Unique ID (UID).

#### Scenario 1

Clear the Device Unique ID (UID) from the form field, or enter “0” and click **Save**.

This causes all of the remaining devices to shift up in slot or “position” to fill the newly cleared slot.

#### Scenario 2

Clear the Device Unique ID (UID) from the form field, then enter “1” and click **Save**.

This holds that slot until the next auto enrollment. This becomes an available position.

Auto enrollment fills the first available position.

#### Scenario 3

Clear the Device Unique ID (UID) from the form field, then enter “2” and click **Save**.

This permanently holds that position until a new Unit ID is entered for this position, (filled manually *only*).

Auto enrollment does *not* fill this position; rather it fills the next open position at the end of the list.

Deletion example: Device 2 needs replacement and is being deleted, with three different scenarios.

Original Device List	Scenario 1	result	Scenario 2	result	Scenario 3	result
1		1		1		1
<b>2</b>	Clear field, type “0”	2	Clear field, type “1”	held*	Clear field, type “2”	held†
3		3		2		2
4		4		3		3
5		5		4		4
6		open		5		5
open		open		open		open††

\* Slot held until the next auto enrollment. This becomes the first available position that auto enrollment fills.

† Slot held for manual enrollment only.

†† Auto enrollment would fill this next open position at the end of the list.

## 12 Enroll State

\Devices\System Devices\Control\Device  
Number:

1 Control ▾

Enroll State

0

Read only field, this is the current state of the CPU. When accessing remotely for programming this area reports back the state of the CPU.

0 = Inactive

1 = Auto Enrollment

2 = Manual Enrollment

## 13 Device Count

\Devices\System Devices\Control\Device  
Number\Device Count:

1 Control ▾

Control

0

Keypad

1

Zone Exp

1

Output Exp

1

This displays the number of additional keypads, zone expanders, and relay expanders currently enrolled on the system.

## 6.9.1.2 Keypads

Keypad details as well as several selections for customizing the keypad operation are available in these submenus.

### 14 Keypad

Keypad enrollment using the automated enrollment process is best achieved by connecting one keypad at a time.

Use the manual process if multiple keypads are connected.

It is recommended to enroll 1 keypad in the system initially.

This allows you to retrieve the system's IP address (or set it if DHCP not enabled in the router), which in turn allows access to the GUI for manually enrolling additional devices.

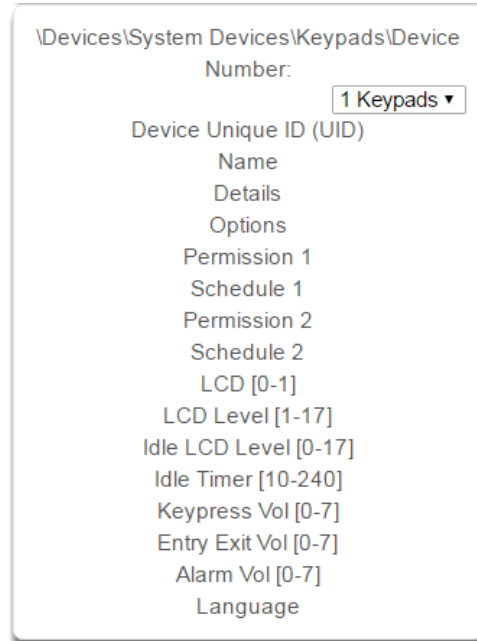

### 15 Device Unique ID (UID)

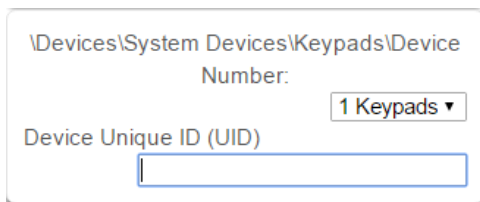

Unique ID number of the keypad.

### 16 Name

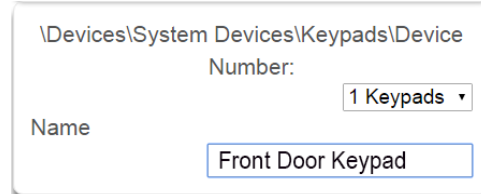

Name of the keypad.

### 17 Keypad Details

Information about the keypad including firmware, hardware versions, etc.

### 19 Keypad Options

**Tamper:** Enable the rear wall tamper switch on the keypad.

**Stay Button:** Enable the Stay button to appear on the main screen, when this is set to N (disabled) it is also called “Commercial Mode”.

**Quick Chime:** Turn global chime on for partitions the keypad and user have permission to access.

**Idle PIN:** Require a valid user PIN to be entered to exit screen saver mode.

**Silent Keypad:** Disable keypad sounds.

**24H Format:** Display the time in 24:00 format.

### 22 Permission 2

Permission 2 is the second permission applied, and checked against, when using the selected keypad. See [Section 7.3, Permissions](#) for details.

### 18 Custom Message

A custom message of up to 16 characters can be entered here.

### 20 Permission 1

Permission 1 is the first permission applied, and checked against, when using the selected keypad. See [Section 7.3, Permissions](#) for details.

### 21 Schedule 1

Schedule 1 refers to when Permission 1 is applied.

### 23 Schedule 2

Schedule 2 refers to when Permission 2 is applied.

### 24 LCD (0-1)

\Devices\System Devices\Keypads\Device  
 Number: 1 Keypads ▾  
 LCD Driver [0-1]

Sets the display mode of the keypad. Do not change this value if the keypad display is working correctly.

### 26 Idle LCD level (0-17)

\Devices\System Devices\Keypads\Device  
 Number: 1 Keypads ▾  
 Idle LCD Level [0-17]

Sets the idle mode brightness of the keypad when it has not been used. This reduces power consumption and glare.

### 28 Keypress Volume

\Devices\System Devices\Keypads\Device  
 Number: 1 Keypads ▾  
 Keypress Volume [0-7]

Sets the beep volume when the keys are pressed.

### 30 Alarm Volume

\Devices\System Devices\Keypads\Device  
 Number: 1 Keypads ▾  
 Alarm Volume [0-7]

Sets the alarm volume.

Language Code	Language
0	English (U.S.)
1	English (Australia)
2	English (U.K.)
3	German
4	Dutch
5	Dutch (Belgium)

### 25 LCD Level (1-17)

\Devices\System Devices\Keypads\Device  
 Number: 1 Keypads ▾  
 LCD Level [1-17]

Sets the normal brightness level of the keypad,

### 27 Idle Timer (10-240)

\Devices\System Devices\Keypads\Device  
 Number: 1 Keypads ▾  
 Idle Timer [10-240]

Sets the screen timeout when not used, and dims the screen from LCD Level to Idle LCD Level.

### 29 Entry Exit Volume

\Devices\System Devices\Keypads\Device  
 Number: 1 Keypads ▾  
 Entry Exit Volume [0-7]

Sets the volume of the warning beeps used during entry and exit delays.

### 31 Language

\Devices\System Devices\Keypads\Device  
 Number: 1 Keypads ▾  
 Language

Enter the language code to set the default language of the keypad interface. Only select languages will be available depending on your region. See below.

Language Code	Language
6	French (Belgium)
7	French
8	Italian
9	Spanish
10	Portuguese
11	Greek

### 6.9.1.3 Zone Expansion Modules

Zone and wireless expansion modules must be enrolled into the system then programmed for proper operation to be achieved. This section details the programming of these devices after they have been enrolled. Note that it is only required to program the hardwired zones on the wireless expansion module if you elect to utilize them. It is not required to program the start and end zone for the wireless sensors. Care must be taken to not learn a wireless sensor into a zone that is programmed as a hardwired input. Wireless sensors currently can be learned in as sensors 1-192.

#### 32 Zone Expanders

```

\Devices\System Devices\Zone
Expanders\Device Number:
    1 Zone Expanders ▼
    Device Unique ID (UID)
    Expander Name
    Expander Details
    Zone Start and End
    Expander Options
    
```

#### 33 Device Unique ID (UID)

```

\Devices\System Devices\Zone
Expanders\Device Number:
    1 Zone Expanders ▼
    Device Unique ID (UID)
    
```

Unique ID of the zone expander.

#### 34 Expander Name

```

\Devices\System Devices\Zone
Expanders\Zone Exp Number:
    1 Zone Expanders ▼
    Expander Name
    
```

Name of the zone expander.

#### 35 Expander Details

```

\Devices\System Devices\Zone
Expanders\Zone Exp Number\Expander
Details:
    1 Zone Expanders ▼
    Model
    Firmware Version
    Hardware Version
    Bootload Version
    Memory Map Version
    
```

Details of the expander module.

#### 36 Zone Start and End

```

\Devices\System Devices\Zone
Expanders\Zone Exp Number\Zone Start
and End:
    1 Zone Expanders ▼
    Starting Zone
    Ending Zone
    
```

After enrolling a zone or wireless expansion module, its zone range (Start Zone and End Zone) must be programmed. Each module has its own range. The start zone needs to account for CPU zones and other existing modules. (The CPU can be 8 to 16 zones depending on the implementation of zone doubling).

#### 37 Expander Options

```

\Devices\System Devices\Zone
Expanders\Zone Exp Number\Expander
Options:
    1 Zone Expanders ▼
    Tamper Enable 
    Output Enable 
    
```

Tamper enables tamper monitoring on the module. Connect an external tamper switch to the tamper connector on the module. If Output Enable is checked, the output operates as the smoke detector reset on 4 wire smoke detectors.

**Note:** If you are working with a Wireless Expander, the Output Enable option is unavailable.

Default Zone Expander Settings		
	8 Zone Exp.	20 Zone Exp.
Start Zone	9	9
End Zone	16	28

Not all of the zones of a module need to be used but the zones must be used in order starting at #1 on the module

For example: Use a 20 zone module to add 12 zones to an eight zone (CPU only) system.

Your Start Zone is # 9.

Your End Zone is # 20.

You must wire zones 1 – 12 on the expander.

There are now 8 *unused* zones available in the system's total count of available zones.

**Note:** The default start and end zones for the wireless expander are 0 and 0. This disables the two hardwired zones on the wireless expander.

### 6.9.1.4 Relay Expansion Modules

Relay expansion modules must be enrolled into the system then programmed for proper operation to be achieved. This section details the programming of these devices after they have been enrolled.

#### 38 Relay Expanders

\Devices\System Devices\Relay  
Expanders\Device Number:

Device Unique ID (UID)  
Expander Name  
Expander Details  
Program Relays  
Expander Options

#### 39 Device Unique ID (UID)

\Devices\System Devices\Relay  
Expanders\Device Number:

Device Unique ID (UID)

Unque ID (UID) of the relay expander.

#### 40 Expander Name

\Devices\System Devices\Relay  
Expanders\Expander Number:

Expander Name

Name / number of the relay expander.

#### 41 Expander Details

\Devices\System Devices\Relay  
Expanders\Expander Number\Expander  
Details:

Model

Firmware Version  
Hardware Version  
Bootload Version  
Memory Map Version

Details of the Relay Expander

#### 42 Program Relays

\Devices\System Devices\Relay  
Expanders\Expander Number\Program  
Relays\Relay Number:

Name  
Select Action  
Schedule  
Invert

#### 43 Relay number name

\Devices\System Devices\Relay  
Expanders\Expander Number\Program  
Relays\Relay Number:

Name

Name of the relay you are programming.

#### 44 Select Action

\Devices\System Devices\Relay  
Expanders\Expander Number\Program  
Relays\Relay Number\Select Action:

Action

Select the action trigger that will activate the relay.

**45** Schedule

Sets when the relay expander is activated.

**47** Expander Options

Enables tamper monitoring on the module. Connect an external tamper switch to the tamper connector on the module.

**46** Options

Invert option is the only option currently available.

The Default relay position is NC (normally closed). If the “Invert” tick box is selected when configuring the relay, then the relay will be in the NO (normally open) position (and energized, consuming power).



### 6.9.1.5 Smart Power Supply Modules

The UM-SPS Smart Power supply module must be enrolled into the system then programmed for proper operation to be achieved. This section details the programming of the power supply after it has been enrolled. Note that it is only required to program the hardwired zones and relays on the module if you elect to utilize them.

\Devices\System Devices\Power Supply\Device Number:

Device Unique ID (UID)

Expander Name

Expander Details

Expander Relays

Zone Start and End

Expander Options

Transformer

#### 48 Device Number

\Devices\System Devices\Power Supply\Device Number:

Device Unique ID (UID)

Unique ID (UID) of the power supply module.

#### 49 Serial Number

\Devices\System Devices\Power Supply\PS Number:

Expander Name

Name of the power supply module. Enter a unique, descriptive name that will aid in troubleshooting (e.g. Warehouse relays)

#### 50 Expander Details

\Devices\System Devices\Power Supply\PS Number\Expander Details:

Model

Firmware Version

Hardware Version

Bootload Version

Memory Map Version

Details of the power supply module.

#### 51 Expander Relays

\Devices\System Devices\Power Supply\PS Number\Expander Relays:

Relay 1

Relay 2

Relay 1 and Relay 2:  
Select the action trigger for relay 1 and relay 2.

### 52 Zone Start and End

After enrolling a power supply module, its zone range (Start Zone and End Zone) must be programmed. Each module requires its own range.

The start zone needs to account for CPU zones and other existing zone modules. (The CPU can be 8 to 16 zones depending on the implementation of zone doubling).

**Note:** The default start and end zones for the wireless expander are 0 and 0. This disables the two hardwired zones on the power supply module.

### 53 Expander Options

Enables tamper monitoring on the module. Connect an external tamper switch to the tamper connector on the module.

### 54 Transformer

The transformer selection is not a configurable field.

## 6.9.2 Interlogix Transmitters

### 55 Interlogix Transmitters

Number of the Interlogix Transmitter. This refers to all wireless sensors and keyfobs.

### 57 User

By default all keyfobs are reported as user 999. To enable individual keyfob reporting, assign a user number here.

### 59 Scene

On a four-button keyfob, this allows the user to activate a scene when the fourth button is pressed.

### 56 Serial Number

Serial number of the Interlogix Device

### 58 Transmitter Options

Allows the Installer to configure options for wireless transmitters including:

- Tamper
- Police
- Auxiliary
- Disable Supervision
- Disable Internal Reed – this applies to transmitters with an internal reed switch
- Norm Open External Contact
- No Siren on Police

### 6.9.3 Z-Wave Devices

#### 60 Z-Wave Devices

\Devices\Zwave Devices\Device Number:

Name  
 Basic Type  
 Generic Type  
 Specific Type

#### 61 Z-Wave Devices Name

\Devices\Zwave Devices\Device Number:

Name

#### 62 Z-Wave Devices Basic Type

\Devices\Zwave Devices\Device Number:

Basic Type

#### 63 Z-Wave Devices Generic Type

\Devices\Zwave Devices\Device Number:

Generic Type

#### 64 Z-Wave Devices Specific Type

\Devices\Zwave Devices\Device Number:

Specific Type

## 6.9.4 Tablet Keypads

### 65 Tablet Keypads

\Devices\Tablet Keypads\Keypad Number: 1 Keypad Number ▾  
 Keypad Name  
 Serial Number  
 Area Group  
 Keypad Options

### 67 Tablet Serial Number

\Devices\Tablet Keypads\Keypad Number: 1 Keypad Number ▾  
 Serial Number

The serial number of the Tablet Keypad

### 69 Keypad Options

\Devices\Tablet Keypads\Keypad Number\Keypad Options:  
1 Keypad Number ▾  
 Silent Keypad   
 Require PIN For Scene

### 66 Tablet Keypad Name

\Devices\Tablet Keypads\Keypad Number: 1 Keypad Number ▾  
 Keypad Name

The name of the Tablet Keypad

### 68 Area Group

\Devices\Tablet Keypads\Keypad Number: 1 Keypad Number ▾  
 Area Group  
 ▾

The area the Tablet Keypad is assigned to

## 6.10 Advanced Programming, Permissions

Click the Advanced bar and select **Permissions** from the menu to program permissions options.

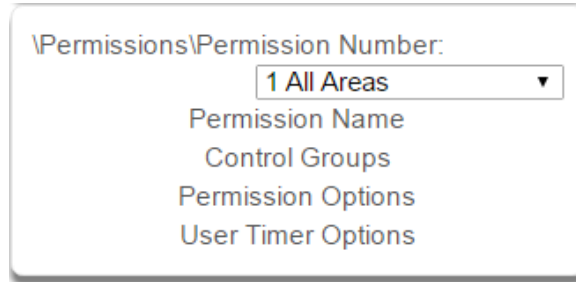

Permissions control what a user or device has access to on the system and what they can do.

### Permissions Submenus

#### 1 Permission Number

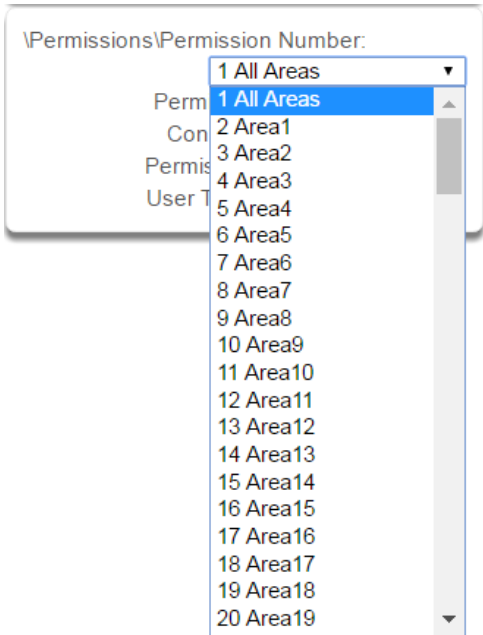

The dropdown menu for '\Permissions\Permission Number:' is open, showing a list of 20 options: '1 All Areas', '2 Area1', '3 Area2', '4 Area3', '5 Area4', '6 Area5', '7 Area6', '8 Area7', '9 Area8', '10 Area9', '11 Area10', '12 Area11', '13 Area12', '14 Area13', '15 Area14', '16 Area15', '17 Area16', '18 Area17', '19 Area18', and '20 Area19'. The first option, '1 All Areas', is highlighted in blue.

#### 2 Permission Name

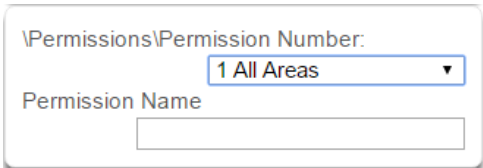

The configuration window for '\Permissions\Permission Number:' shows the dropdown menu set to '1 All Areas'. Below it, the 'Permission Name' field is an empty text box.

Permissions Submenus

The system can support a total of 128 Permission scenarios. Each scenario is identified by a unique number, which cannot be altered, and remains as the key reference for each Permission.

Each Permission scenario can be configured with a custom 32 character name. The name is displayed wherever Permissions are referenced on the system.

### 3 Control Groups

\Permissions\Permission Number\Control Groups:

1 All Areas ▼

Menu Group 1 Menu ▼

Arm Area Group 125 All Areas ▼

Disarm Area Group 125 All Areas ▼

Reset Only Area Group 125 All Areas ▼

Timed Disarm Area Group 125 All Areas ▼

Man Down Area Group 125 All Areas ▼

Guard Tour Area Group 125 All Areas ▼

Area Display Group 125 All Areas ▼

Report Channel Group 1 Channel Group ▼

Stay Arm Area Group 125 All Areas ▼

Action Group disabled ▼

#### 1. Menu Group

This controls what menus the user or device can access

#### 2. Arm Area Group

This controls which areas can be armed.

#### 3. Disarm Area Group

This controls which areas can be disarmed.

#### 4. Reset Only Area Group

This controls which areas can be reset only.

For example, if a guard is present on the site you may not want them to be able to disarm any areas. By assigning them a Reset Only Area Group, they can turn off alarms, but they cannot accidentally disarm an area.

#### 5. Timed Disarm Area Group

This controls which areas can be timed disarm.

#### 6. Man Down Area Group

This controls which areas will have man down monitoring.

#### 7. Guard Tour Area Group

This controls which areas are a part of the guard tour.

#### 8. Area Display Group

This controls what areas can display area status.

#### 9. Report Channel Group

This controls what channels the user can modify.

#### 10. Stay Arm Area Group

This controls what areas can be stay armed.

#### 11. Action Group

This controls what actions can be displayed or accessed.

## 4 Permission Options

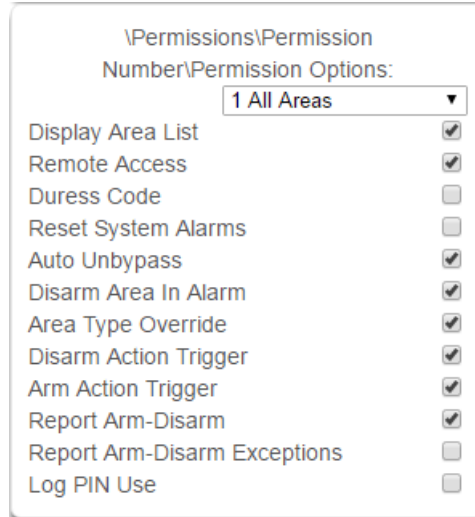

**1. Display Area List** - When this feature is enabled on a multi-area system and a user requests to arm/disarm from the main screen of the keypad, the keypad will display the area control screen that will allow them to arm individual areas. If this feature is disabled, the keypad will automatically arm/disarm all areas. This operation applies to Custom user types. You can enable or disable this feature for non-Custom users in the Users Menu.

**2. Remote Access** - Enables and disables remote web access to the permission. If this is not enabled, a user will not be able to access the web interface directly or via a smartphone app.

**3. Duress Code** - designates this user as a duress code, whenever this code is used a duress message is sent.

**4. Reset System Alarms** - when System Option - System Alarm Latch is enabled, system alarms include panel box tamper can only be reset by a user with this permission. Users without this permission will be able to arm and disarm areas as normal, but system alarms will stay latched.

**5. Auto Un-Bypass** - When enabled, a bypassed sensor will be reset when disarming. When disabled, the Sensor will remain bypassed even after the system has been disarmed.

**6. Disarm Area In Alarm** - When disabled, this user will not be able to disarm and reset an area in alarm. Even if the user has permission in their Disarm Area Group, this option will override disarm authority.

**7. Area Type Override** - Applies to non-standard area types 'Time Disarm' 'Man Down' 'Guard Tour'. When set, disables the feature for the user.

**8. Disarm Action Trigger** - When enabled, this users will trigger the Action trigger event "User Disarm Trigger" when disarming an area, used in conjunction with for programming actions.

**9. Arm Action Trigger** - When enabled, this user will trigger the Action trigger event "User Arm Trigger" when arming an area, used in conjunction with for programming actions.

**10. Report Arm/Disarm** - Where a system is already configured to send Arm-Disarm reports this option allows a user to NOT send a report. When enabled the reports will be sent. When disabled reports will not be sent.

**11. Report Arm-Disarm Exceptions** –  
Report Arm-Disarm Exceptions = ON:

All four reports are sent as appropriate.

Early Opening

'Fail To Open' and the reset report 'Late Open'

Early Close

'Fail To Close' and the reset report 'Late Closing'

Report Arm-Disarm Exceptions = OFF:

As expected the only reports are the 'Fail To Open' and 'Fail To Close' reports with their respective resets 'Late Open' and 'Late Close'. Both the 'Early Open' and 'Early Close' reports were suppressed.

'Fail To Open' and the reset report 'Late Open'

'Fail To Close' and the reset report 'Late Closing'

See [Area Type](#) for more details.

**12. Log PIN Use** - Log will show "Valid Code Entered" when enabled. Must be enabled to allow actions and scene events to monitor user interaction. Also see how to set up having users trigger scenes in the Activate Event Type List. See [Advanced Programming, Scenes](#).



## 5 User Timer Options

\Permissions\Permission Number\User  
Timer Options:  
1 Permission ▼  
Disarm Time [0-999] Minutes  
0  
Man Down Time [0-999] Minutes  
0  
Guard Tour Time [0-999] Minutes  
0

1. Disarm Time
2. Man Down Time
3. Guard Tour Time

These timers apply to a user when allocated this permission and:

- the Area Type is set to Timed Disarm, Man Down, or Guard Tour,
- is inside Area Type schedule,
- and Area Type Override is NOT enabled under Permission Options

If the value of the associated timer is zero, then the system will apply a timer of 45min.

See Area Type Settings for a more detailed description on these features.

## 6.11 Advanced Programming, Area Groups

Click the Advanced bar and select **Area Groups** from the menu to program area groups options.

The system can support a total of 16 Area Groups. Each Area Group is identified by a unique number, which cannot be altered, and remains as the key reference for each area.

When assigned to a user, an Area Group controls what areas the user can see and control. When assigned to a sensor or device, an Area Group determines what Areas that sensor/device will report and display in.

### Area Groups Submenus

Area Groups Submenus

#### 1 Area Group Number

Area Groups\Area Group Number: 1 Area 1 ▼

Area Group Name

Area List

The system can support a total of 128 Area Groups. Each Area Group is identified by a unique number, which cannot be altered, and remains as the key reference for each area.

#### 2 Area Group Name

Area Groups\Area Group Number: 1 Area 1 ▼

Area Group Name

Each group can be configured with a custom 32 character name. The name is displayed wherever an Area Group is referenced on the system.

#### 3 Area List

Area Groups\Area Group Number: 1 Area 1 ▼

1 Area	<input checked="" type="checkbox"/>
2 Area	<input type="checkbox"/>
3 Area	<input type="checkbox"/>
4 Area	<input type="checkbox"/>

Select the areas that should be part of this Area Group.

C 154 P/N 466-5261 • REVA • ISS 10JAN17

UltraSync Modular Hub Reference Manual

©2017 United Technologies Corporation

## 6.12 Advanced Programming, Menus

Click the Advanced bar and select **Menus** from the menu to program menu options.

Menus are assigned to users and devices to control what menus can be accessed. A total of 64 Menus can be configured.

M e n u s   S u b m e n u s

### 1 Menu Number (1 – 64)

\Menus\Menu Number: 1 Menu ▾

Menu Name

Menu Selections

The system can support a total of 64 Menu Groups. Menu Groups are assigned to users and devices to control what menus can be accessed. Each Menu is identified by a unique number, which cannot be altered, and remains as the key reference for each Menu.

### 2 Menu Name

\Menus\Menu Number: 1 Menu ▾

Menu Name

Each Menu can be configured with a custom 32 character name. The name is displayed wherever a Menu is referenced on the system.

### 3 Menu Selections

\Menus\Menu Number\Menu Selections: 1 Menu ▾

History	<input checked="" type="checkbox"/>
Cameras	<input checked="" type="checkbox"/>
Lights	<input checked="" type="checkbox"/>
HVAC	<input checked="" type="checkbox"/>
Smoke Reset	<input checked="" type="checkbox"/>
Users	<input checked="" type="checkbox"/>
Testing	<input checked="" type="checkbox"/>
Reporting	<input checked="" type="checkbox"/>
Scenes	<input checked="" type="checkbox"/>
Clock	<input checked="" type="checkbox"/>
Holidays	<input checked="" type="checkbox"/>
Schedules	<input checked="" type="checkbox"/>
Entry & Exit	<input checked="" type="checkbox"/>
Z-Wave	<input checked="" type="checkbox"/>
Labels	<input checked="" type="checkbox"/>
Keypad Setting	<input checked="" type="checkbox"/>
Devices	<input checked="" type="checkbox"/>
Status	<input checked="" type="checkbox"/>
Advanced	<input type="checkbox"/>

Check each item to give a user access to that menu. For example, checking Labels permits a user with this Menu in their permission to change the text labels (names) of sensors, areas, outputs, etc.

M e n u s   S u b m e n u s

## 6.13 Advanced Programming, Holidays

Click the Advanced bar and select **Holidays** from the menu to program holidays options.

Also reference Section 5.9, [Programming Holidays](#)

Holidays Submenus

### 1 Holiday Number (1 – 4)

\Holidays\Holiday Number:

Holiday Name	1 Holiday ▾
Date Range	1 Holiday
	2 Holiday
	3 Holiday
	4 Holiday

The system can support a total of 4 Holiday Sets. Each set can have up to 16 date ranges. Holidays are used as part of Schedules to control access to the system on specified dates.

### 2 Holiday Name

\Holidays\Holiday Number:

1 Holiday ▾

Holiday Name

Each holiday can be configured with a custom 32 character name. The name is displayed wherever a Holiday is referenced on the system.

### 3 Holiday Date Range

\Holidays\Holiday Number\Date Range\Range Number:

	1 Holiday ▾
	1 Range Number ▾
Start Date	11/22/2014
End Date	11/22/2014

Select the date range for the Holiday by specifying the start and stop date. A total of 16 ranges can be entered for each Holiday.

Holidays Submenus

## 6.14 Advanced Programming, Sensor Types

Click the Advanced bar and select **Sensor Types** from the menu to program sensor types options.

Sensors can be programmed to be one of 32 different sensor configurations (sensor type profiles). Sensors are fully configurable in the system. These features are considered advanced programming and should only be changed by an installer with a thorough understanding of the features.

Sensor type profiles can also change depending on whether the area they are in are armed or disarmed. This provides the ultimate flexibility in panel programming.

Sensor Types Submenus

**1 Sensor Type Number (1 – 32)**

\Sensor Types\Sensor Type Number:

1 Day Zone ▼

Sensor Type Name

Sensor Type Armed

Sensor Type Disarmed

The system can support a total of 32 Sensor Types. Each Sensor Type is identified by a unique number, which cannot be altered, and remains as the key reference for each Sensor Type.

**2 Sensor Type Name**

\Sensor Types\Sensor Type Number:

1 Day Zone ▼

Sensor Type Name

Day Zone

Each Sensor Type can be configured with a custom 32 character name. The name is displayed wherever a Sensor Type is referenced on the system.

Sensor type profiles can also change depending on whether the areas they are in are armed or disarmed. This provides a new level of flexibility in panel programming.

**Armed**

\Sensor Types\Sensor Type Number\Sensor Type Armed: ●

1 Day Zone ▼

Sensor Attribute

Siren Attribute

Sensor Attribute Options

**Disarmed**

\Sensor Types\Sensor Type Number\Sensor Type Disarmed: ●

1 Day Zone ▼

Sensor Attribute

Siren Attribute

Sensor Attribute Options

Sensor Types Submenus

### 3 Sensor Type Profile / Armed

#### Sensor Attribute

This is how the sensor will behave when the area it is in is armed.

- Disabled – sensor is disabled.
- Entry 1 – sensor will follow area entry/exit timer 1.
- Entry 2 – sensor will follow area entry/exit timer 2.
- Follower – instant alarm type unless an entry sensor is tripped first.
- Instant – sensor goes into alarm as soon as it is tripped.
- Trouble Sensor – typically used on fire doors to the exterior of a building. When the system is disarmed they report trouble and sound a buzzer. When the system is armed they are instant burg alarms.
- Fire – smoke detectors must be wired Normally Open. A short on a fire sensor will create an alarm condition when the system is armed or disarmed. An open will create a Trouble condition that is always reported for this sensor type, regardless of the Sensor Trouble reporting option. Keypad sensor LED is steady for fire condition and flashing for trouble condition. After fire activation, use the keypad to clear & reset fire sensor by pressing Sensor Reset.
- Holdup delay – when tripped, starts the hold up timer, if the timer is reached then a hold up alarm is sent.
- Holdup reset – when this sensor is tripped, the hold up timer is stopped.
- Keyswitch – A momentary key switch can be used to arm/disarm the panel when it is momentarily shorted from a closed condition. Use a 3.3K resistor for this sensor type. Or if DEOL monitoring is enabled in System Options, use two 3.3K resistors to allow full line monitoring.
- Event Only – this sensor only creates an event when tripped and is stored in the event log.

#### Siren Attribute

Select from these 4 options to control what sound the siren makes when this sensor goes into alarm.

- Silent – siren makes no sound
- Fire – temporal three pulse siren
- Yelping – siren makes a yelping sound
- Four Pulse – temporal four pulse siren

### 4 Sensor Type Profile / Disarmed

This is how the sensor will behave when the area it is in is disarmed.

- Disabled – sensor is disabled.
- Instant – sensor goes into alarm as soon as it is tripped.
- Trouble Sensor – typically used on fire doors to the exterior of a building. When the system is disarmed they report trouble and sound a buzzer. When the system is armed they are instant burg alarms.
- Fire – smoke detectors must be wired Normally Open. A short on a fire sensor will create an alarm condition when the system is armed or disarmed. An open will create a Trouble condition that is always reported for this sensor type, regardless of the Sensor Trouble reporting option. Keypad sensor LED is steady for fire condition and flashing for trouble condition. After fire activation, use the keypad to clear & reset fire sensor by pressing Sensor Reset.
- Holdup delay – when tripped, starts the hold up timer, if the timer is reached then a hold up alarm is sent.
- Holdup reset – when this sensor is tripped, the hold up timer is stopped.
- Keyswitch – A momentary key switch can be used to arm/disarm the panel when it is momentarily shorted from a closed condition. Use a 3.3K resistor for this sensor type. Or if DEOL monitoring is enabled in System Options, use two 3.3K resistors to allow full line monitoring.
- Event Only – this sensor only creates an event when tripped and is stored in the event log.

#### Siren Attribute

See descriptions above. This is how the siren will behave when the area it is in is disarmed.

## 5 Sensor Attribute Options (Armed or Disarmed)

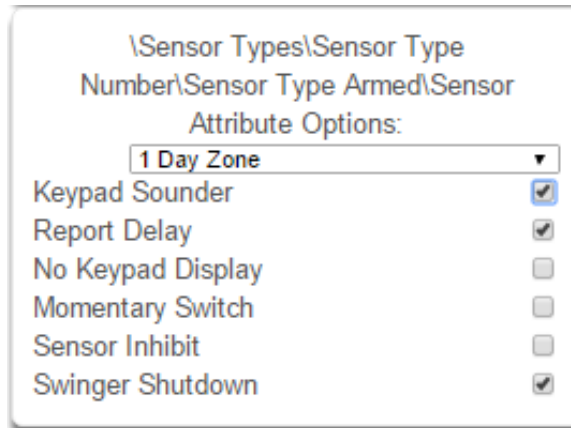

- Keypad Sounder – If enabled, the panel will announce alarm, tamper, or trouble conditions. Default is on.
- Report Delay – if enabled, the system will delay reporting sensor activations until the next scheduled report. This setting is ignored if the sensor is a Fire type and sensor activations are reported immediately. When disabled sensor activations (trip, bypass and restorals) are reported immediately. Default is off.
- No Keypad Display – if enabled, any sensor conditions such as alarm and tamper will not illuminate the Alarm Light. Conditions will still report and function as normal. Default is off.
- Momentary Switch – if enabled, the sensor will not latch. If it is triggered again then it will send another report immediately. Default is off.
- Sensor Inhibit (Bypass) – This feature is designed to reduce false alarms at arming/disarming. If enabled, a sensor that is currently faulted that could cause an alarm condition will be temporarily bypassed when changing armed states.

This typically occurs when forced arming and the sensor is open, or when a schedule change occurs that changes the sensor type. The bypass will be applied to the sensor if it remains open at the end of the exit timer. Default is off.

- Swinger Shutdown

Swinger Shutdown is a false alarm prevention feature that counts the number of alarms caused by a specific sensor.

## Sensor Types Table

**Note:** When initiating Away arming, a sensor with the default sensor attributes of Entry 1, Entry 2 and Follower must be tripped during the exit delay to arm the system in the Away mode. If one of these sensors is not tripped during the exit delay the system will arm in the Stay mode. (CP-01 requirement)

Preset Number	Preset Name	Sensor Attribute	Siren Attribute	Keypad Sounder	Report delay	No Keypad Display	Momentary Switch	Sensor Inhibit (Bypass)	Swinger Shutdown
<b>Armed</b>									
1	Day Zone	Instant	Yelping	Y	Y	N	N	N	Y
2	24 Hour Audible	Instant	Yelping	Y	Y	N	N	N	Y
3	Entry Exit Delay 1	Entry 1	Yelping	Y	Y	N	N	N	Y
4	Entry Exit Delay 2	Entry 2	Yelping	Y	Y	N	N	N	Y
5	Follower	Follower	Yelping	Y	Y	N	N	N	Y
6	Instant	Instant	Yelping	Y	Y	N	N	N	Y
7	24 Hour Silent	Instant	Silent	N	Y	N	N	N	Y
8	Fire Alarm	Fire	Fire	Y	N	N	N	N	N
9	Entry Exit Delay 1 Auto-Bypass	Entry 1	Yelping	Y	Y	N	N	Y	Y
10	Entry Exit Delay 2 Auto-Bypass	Entry 2	Yelping	Y	Y	N	N	Y	Y
11	Instant Auto-Bypass	Instant	Yelping	Y	Y	N	N	Y	Y
12	Event Only	Event Only	Silent	N	N	Y	N	N	N
13	Momentary Key Switch	Keyswitch	Silent	N	N	N	Y	N	N
14	Latching Key Switch	Keyswitch	Silent	N	N	N	N	N	N
15	CO Detector	Instant	Four Pulse	Y	N	N	N	N	N
<b>Disarmed</b>									
1	Day Zone	Trouble Sensor	Yelping	Y	N	N	N	N	N
2	24 Hour Audible	Instant	Yelping	Y	Y	N	N	N	Y
3	Entry Exit Delay 1	Event Only	Silent	N	N	N	N	N	N
4	Entry Exit Delay 2	Event Only	Silent	N	N	N	N	N	N
5	Follower	Event Only	Silent	N	N	N	N	N	N
6	Instant	Event Only	Silent	N	N	N	N	N	N
7	24 Hour Silent	Instant	Silent	N	Y	N	N	N	Y
8	Fire Alarm	Fire	Fire	Y	N	N	N	N	N
9	Entry Exit Delay 1 Auto-Bypass	Event Only	Silent	N	N	N	N	N	N
10	Entry Exit Delay 2 Auto-Bypass	Event Only	Silent	N	N	N	N	N	N
11	Instant Auto-Bypass	Event Only	Silent	N	N	N	N	N	N
12	Event Only	Event Only	Silent	N	N	Y	N	N	N
13	Momentary Key Switch	Keyswitch	Silent	N	N	N	Y	N	N
14	Latching Key Switch	Keyswitch	Silent	N	N	N	N	N	N
15	CO Detector	Instant	Four Pulse	Y	N	N	N	N	N



## 6.15 Advanced Programming, Sensor Options

Click the Advanced bar and select **Sensor Options** from the menu to program sensor options.

Sensors are fully configurable in the system. These features are considered advanced programming and should only be changed by an installer with a thorough understanding of the features.

### Sensor Options Submenus

#### 1 Sensor Options Number (1 – 32)

\Sensor Options\Sensor Options Number:

1 Bypass ▾

Sensor Options Name

Sensor Options

Sensor Reporting

Sensor Contact Options

Sensor Report Event

#### 2 Sensor Options Name

\Sensor Options\Sensor Options Number:

1 Bypass ▾

Sensor Options Name

Bypass

The system can support a total of 32 Sensor Options. Each Sensor Option is identified by a unique number, which cannot be altered, and remains as the key reference for each Sensor Option.

Each Sensor Option can be configured with a custom 32 character name. The name is displayed wherever a Sensor Option is referenced on the system.

Sensor Options Submenus

### 3 Sensor Options

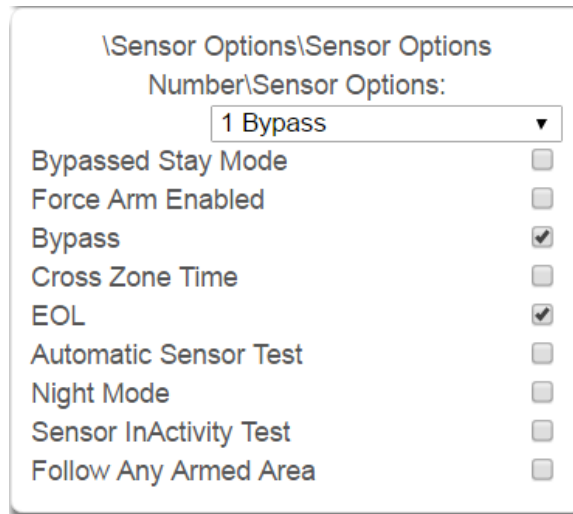

Also see the [Sensor Options Table](#) for reference.

- Bypassed Stay Mode – if enabled, this sensor is automatically bypassed when the area is armed in stay mode. For example, it is an interior sensor.
- Force Arm Enabled – if enabled, this sensor type may be open while arming if forced arming is enabled in the area options. Normally all sensors in an area must be closed before a user can attempt to arm that area.
- Bypass – if enabled, this sensor may be bypassed.
- Cross Zone– This sensor type will require two triggers or another sensor would have to have been triggered before it will activate an alarm.
- EOL – Enable End Of Line resistor tamper monitoring
- Automatic Sensor Test – if enabled, this test is controlled by action results automatic test on and off.
- Night Mode – If enabled, sensor is bypassed in Stay Mode or Instant Stay Mode, and active in Stay Night Mode
- Sensor Inactivity Test – if enabled, this sensor will check for Sensor Inactivity. The Sensor Inactivity setting must be enabled in [General Options](#). The time is programmed in Advanced Programming, System – [System Timers](#). See Programming the System, Section 5.4.
- Follow Any Armed Area – If enabled, and a sensor is in more than 1 area it will create an alarm if triggered when any area is armed. If this feature is off then all the areas must be armed before the sensor will become active.

#### 4 Sensor Reporting

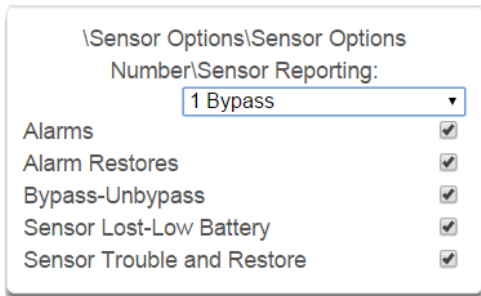

- Alarms Reporting – if enabled, this sensor will report alarms.
- Alarm Restores Reporting – if enabled, this sensor will report alarm restores.
- Bypass-Unbypass Reporting – if enabled, this sensor will report bypasses and unbypass restorals.
- Sensor Lost-Low Battery Reporting – if enabled, this sensor will report loss of wireless supervision and low battery faults.
- Sensor Trouble and Restore – if enabled, this sensor will report sensor trouble and restorals. Fire type sensors will always report regardless of this option.

#### 6 Sensor Report Event

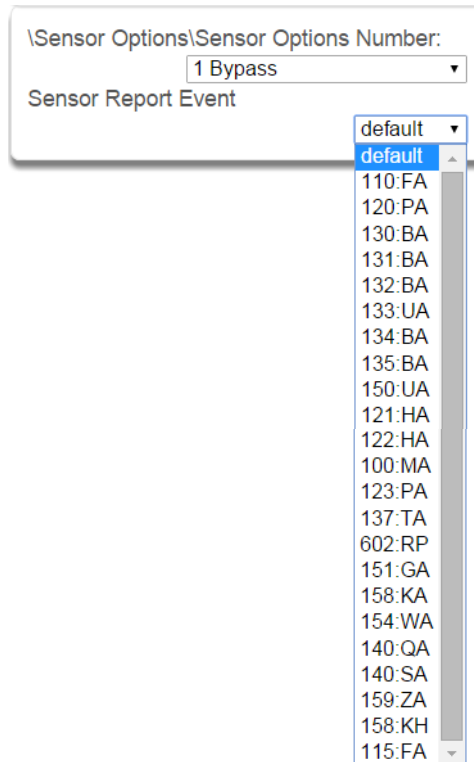

From the drop down menu, select the CID and SIA event code to report when this sensor is tripped.

#### 5 Sensor Contact Options

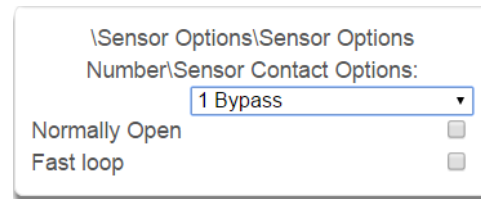

(Applies to the hardwire inputs, not wireless sensors.)

- Normally Open – if enabled, the sensor circuit is normally open. Default is off.
- Fast Loop – if enabled, the system will be more sensitive and respond quicker to a change in state to the sensor. For example, we could enable this on a door contact to trigger the turning on of lights quicker when someone opens the door by using an Action. Depending on the application this may increase the chance of a false alarm if the sensor is used for intrusion detection.

# Sensor Options Table

Preset Number	Preset Name	Bypassed Stay Mode	Forced Arm Enabled	Bypass	Cross Zone Time	EOL	Automatic Sensor Test	Night Mode	Sensor Inactivity Test	Follow Any Armed Area	Alarms reporting	Alarm restore reporting	Bypass-Unbypass reporting	Sensor reporting Lost-Low Battery	Sensor reporting Trouble and Restore	Normally Open	Fast Loop	Sensor Report Event
1	Bypass			x		x					x	x	x	x	x			134:BA
2	Bypass Stay	x		x		x					x	x	x	x	x			132:BA
3	Bypass – Forced Arm		x	x		x					x	x	x	x	x			134:BA
4	Bypass – Cross Zone				x	x					x	x	x	x	x			134:BA
5	Fire		x			x					x	x	x	x	x			110:FA
6	Panic		x			x					x	x	x	x	x			120:PA
7	Silent Panic					x					x	x	x	x	x			122:HA
8	Normally Open no EOL			x							x	x	x	x	x	x		130:BA
9	Normally Closed no EOL			x							x	x	x	x	x			130:BA
10	Gas Detected					x					x	x	x	x	x			151:GA
11	High Temp					x					x	x	x	x	x			158:KA
12	Water Leakage					x					x	x	x	x	x			154:WA
13	Low Temp					x					x	x	x	x	x			159:ZA
14	High Temp					x					x	x	x	x	x			158:KH
15	Fire Alarm Pull Station					x					x	x	x	x	x			110:FA
16	Night Mode	x		x		x		x			x	x	x	x	x			135:BA
17	Blank		x	x		x					x	x	x	x	x			130:BA
18	Blank		x	x		x					x	x	x	x	x			130:BA
19	Blank		x	x		x					x	x	x	x	x			130:BA
20	Blank		x	x		x					x	x	x	x	x			130:BA
21	Blank		x	x		x					x	x	x	x	x			130:BA
22	Blank		x	x		x					x	x	x	x	x			130:BA
23	Blank		x	x		x					x	x	x	x	x			130:BA
24	Blank		x	x		x					x	x	x	x	x			130:BA
25	Blank		x	x		x					x	x	x	x	x			130:BA
26	Blank		x	x		x					x	x	x	x	x			130:BA
27	Blank		x	x		x					x	x	x	x	x			130:BA
28	Blank		x	x		x					x	x	x	x	x			130:BA
29	Blank		x	x		x					x	x	x	x	x			130:BA
30	Blank		x	x		x					x	x	x	x	x			130:BA
31	Blank		x	x		x					x	x	x	x	x			130:BA
32	Blank		x	x		x					x	x	x	x	x			130:BA

## 6.16 Advanced Programming, Event Lists

Click the Advanced bar and select **Event Lists** from the menu to program event lists options.

Event Lists are monitored by Channels to determine if they should be reported. Only events on a Channel's associated Event List will be reported.

### Event Lists Submenus

#### 1 Event List Number (1 – 16)

\Event Lists\Event List Number:  
Event List Name  
Event List

1 Event List ▾

The system can support a total of 16 Event Lists. Each Event List is identified by a unique number, which cannot be altered, and remains as the key reference for each Event List.

#### 2 Event List Name

\Event Lists\Event List Number:  
Event List Name

1 Event List ▾

Each Event List can be configured with a custom 32 character name. The name is displayed wherever an Event List is referenced on the system.

#### 3 Event List

\Event Lists\Event List Number\Event List:  
1 Event List ▾

Alarms	<input checked="" type="checkbox"/>
Alarm Restores	<input checked="" type="checkbox"/>
Arm-Disarm	<input checked="" type="checkbox"/>
Bypass and UnBypass	<input checked="" type="checkbox"/>
Sensor Trouble and Restore	<input checked="" type="checkbox"/>
Sensor Tamper and Restore	<input checked="" type="checkbox"/>
Sensor Lost	<input checked="" type="checkbox"/>
Sensor Low Battery	<input checked="" type="checkbox"/>
Cancel Code	<input checked="" type="checkbox"/>
Recent Arm-Exit Error	<input checked="" type="checkbox"/>
Tampers	<input checked="" type="checkbox"/>
Reporting Trouble	<input checked="" type="checkbox"/>
AC Failure Reporting	<input checked="" type="checkbox"/>
Low Battery	<input checked="" type="checkbox"/>
Aux Power Over-current	<input checked="" type="checkbox"/>
Siren Supervision	<input checked="" type="checkbox"/>
Telephone Line Cut	<input checked="" type="checkbox"/>
Expander Trouble	<input checked="" type="checkbox"/>
Log Full Report	<input checked="" type="checkbox"/>
Autotest	<input checked="" type="checkbox"/>
Start-End Programming	<input checked="" type="checkbox"/>
Start-End Download	<input checked="" type="checkbox"/>
System Troubles	<input checked="" type="checkbox"/>
Access Events	<input checked="" type="checkbox"/>
Video Events	<input checked="" type="checkbox"/>

Select the events that you want to be part of this Event List. If an event message is on an Event List then the Channel will attempt to deliver it. If an event message is not on the Event List assigned to that Channel, it will not attempt delivery even if the message has been sent to it. See how Channel Groups handle event lists in [Advanced Programming, Channel Groups](#).

## 6.17 Advanced Programming, Channel Groups

Click the Advanced bar and select **Channel Groups** from the menu to program channel groups options.

The system provides you powerful and flexible reporting capability through its Channel feature. They are fully configurable to suit your needs by allowing you to specify what events to report to single and multiple destinations, with multiple levels of back up paths.

### Channel Groups Submenus

#### 1 Channel Group Number (1 – 16)

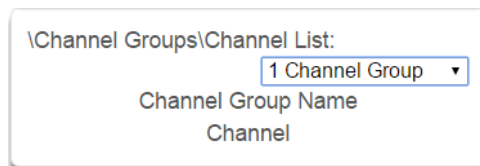

#### 2 Channel Group Name

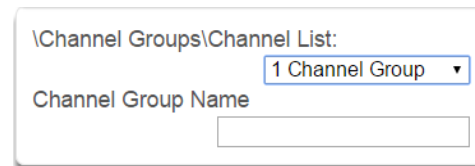

The system can support a total of 16 Channel Groups. Each Channel Groups is identified by a unique number, which cannot be altered, and remains as the key reference for each Channel Group.

Each group can be configured with a custom 32 character name. The name is displayed wherever an Action Group is referenced on the system.

#### 3 Channel List

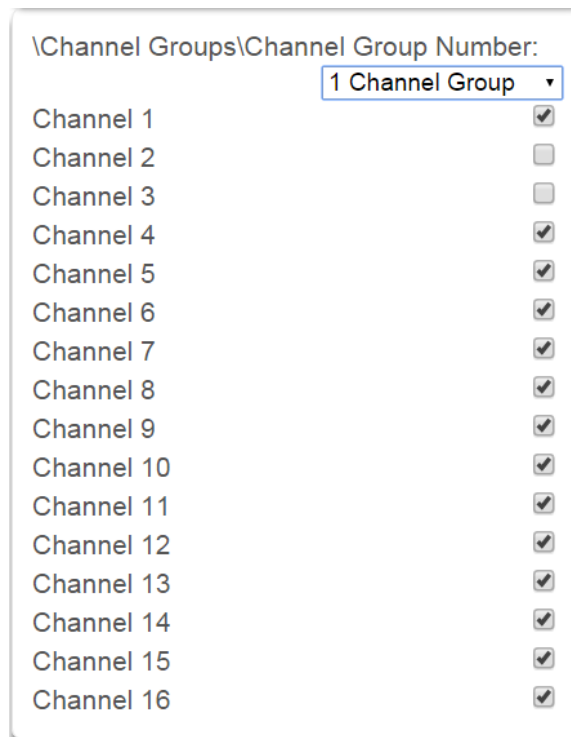

For each Channel Group, select the Channels where the event should be sent.

Channel Groups Submenus

When a **system event** occurs, it is routed to the System Event Channel Group (Communicator\System Event Reporting\System Channels). The Channel Group will forward the event to each of the Channels it contains. If the event is on the Channel's Event List, the Channel will attempt to send the event to the Channel's destination.

### Example System Event

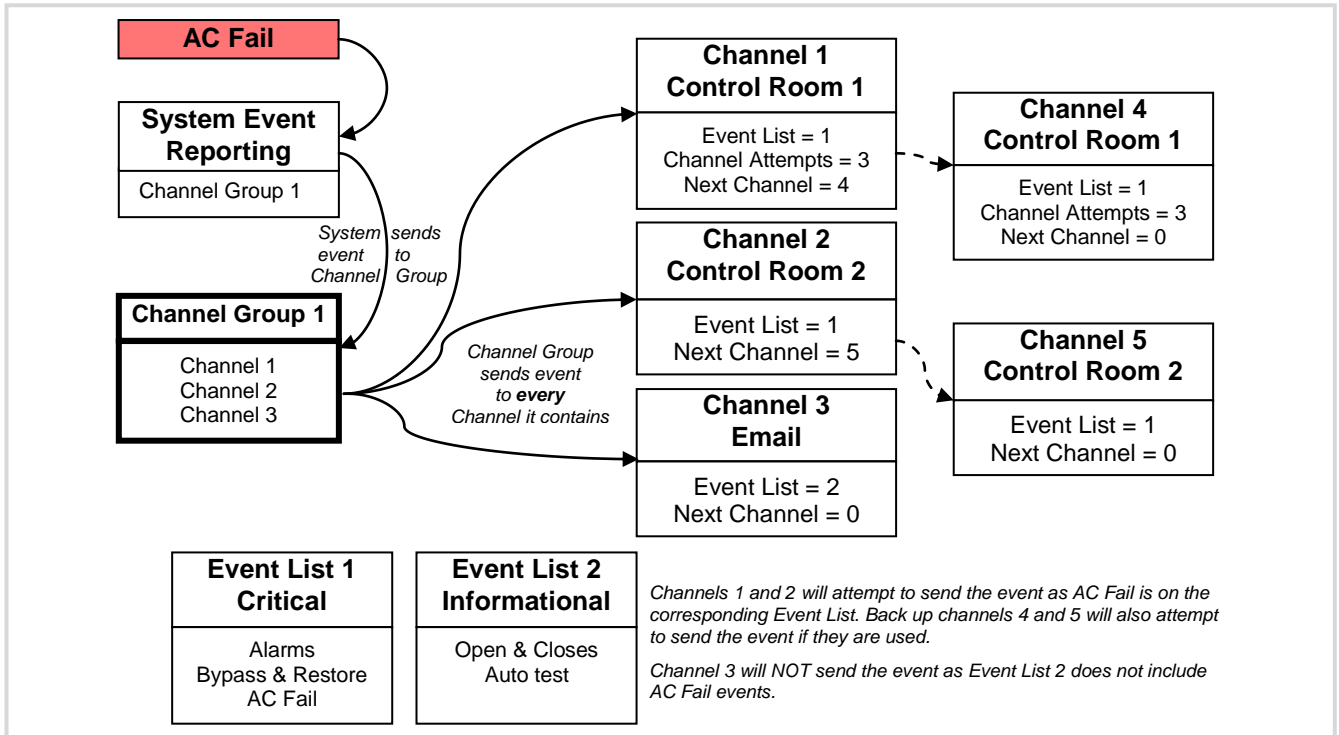

If a **sensor event** or **area event** is generated, then the event is sent to the Channel Group specified (Area – Channel Group) in the lowest area the sensor belongs to. The Channel Group forwards the event to each of the Channels it contains. Each Channel checks its Event List to determine if the event should be sent.

### Example Sensor or Area Event

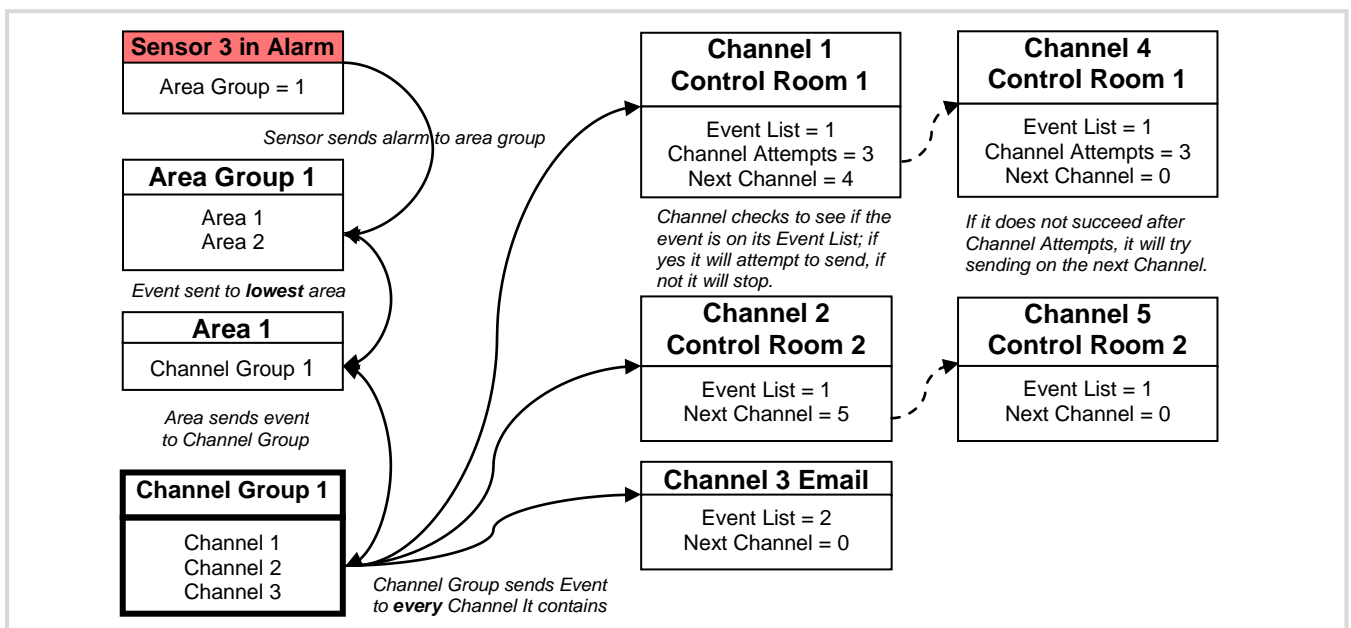

## Customize Reporting Codes

The system has the ability to report Ademco Contact I.D. transmissions. Each report in Contact I.D. consists of an event code and the sensor I.D. generating the alarm.

Programmed Event Code	Contact I.D. Code	SIA Event Code	Description
0	Use default code for Sensor Type	Use default code for Sensor Type	
1	110	FA	Fire Alarm
2	120	PA	Panic Alarm
3	130	BA	Burglary Alarm
4	131	BA	Perimeter Alarm
5	132	BA	Interior Alarm
6	133	UA	24 Hour (Safe)
7	134	BA	Entry/Exit Alarm
8	135	BA	Day/Night Alarm
9	150	UA	Non Burglary 24 Hour
10	121	HA	Duress Alarm
11	122	HA	Silent Panic
12	100	MA	Auxiliary Alarm
13	123	PA	Audible Panic Alarm
14	137	TA	Tamper Alarm
15	602	RP	Periodic Test
16	151	GA	Gas Detected
17	158	KA	High Temp
18	154	WA	Water Leakage
19	140	QA	General Alarm
20	140	SA	General Alarm
21	159	ZA	Low Temp
22	158	KH	High Temp
23	115	FA	Fire Alarm Pull Station

Customize the code reported by following these steps:

1. Login to the Web Server
2. Press **Advanced\Sensor Options**.
3. Select the Sensor Options you want to change.
4. Press **Sensor Report Event**.
5. Select the desired Contact I.D.\SIA Event Code pair from the drop down menu.

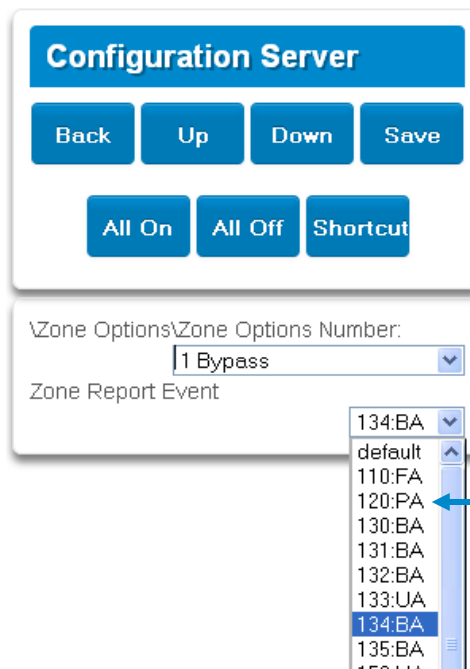



6. Press **Save**.
7. Press **Settings** and Sensors should appear.
8. Assign the customized Sensor Options to the Sensor.

The screenshot displays a three-part interface. The top part is a 'Settings Selector' box with a 'Zones' dropdown menu and 'Up', 'Down', and 'Save' buttons. The middle part is a 'Zone Add/Remove Functions' box with 'Learn', 'Remove', and 'Cancel' buttons. The bottom part is a configuration form titled 'Select Zone to Configure:' with the following fields: '1 Zone' (dropdown), 'Zone Name' (text input), 'Zone Type' (text input), '6 Instant' (dropdown), 'Zone Options' (dropdown with a blue arrow pointing to it), '1 Bypass' (dropdown), 'Area Group' (dropdown with '1 Partition 1'), and 'Serial Number' (text input with '0').

9. Press **Save**.

## Reporting Fixed Codes in Contact I.D.

The table below lists the CID event codes sent for the following reports (if enabled). The number in *brackets* following the event is the number that will be reported as the sensor number if extended Contact I.D. is enabled in the system options. Otherwise sensor '0' will always be reported. If there are no parentheses, the sensor will be reported as '0'.

Report	Contact I.D. Event
Manual Test	601
Auto test Open ( <i>user number</i> )	602
Close ( <i>user number</i> )	401
Cancel ( <i>user number</i> )	406
Download Complete	412
Start Program	627
End Program	628
Ground Fault	310
Ground Fault Restore	310
Recent Close ( <i>user number</i> )	401
Exit Error ( <i>user number</i> )	457
Event Log Full	605
Fail To Communicate	354
Expander Trouble	333
Expander Restore	333
Telephone Fault	351
Telephone Restore	351
Siren Tamper	321
Siren Restore	321
Aux Power Over Current	312
Aux Power Restore	312
Low Battery	309
Low Battery Restore	309
AC Fail	301
AC Restore	301
Box Tamper	137
Box Tamper Restore	137
Panel Tamper	137
Panel Panic	120
Duress	121
Panel Fire	110
Panel Auxiliary	100
RF Sensor Lost ( <i>sensor number</i> )	381
RF Sensor Restore ( <i>sensor number</i> )	381
Sensor Low Battery ( <i>sensor number</i> )	384
Sensor Battery Restore ( <i>sensor number</i> )	384
Sensor Trouble ( <i>sensor number</i> )	380
Sensor Trouble Restore ( <i>sensor number</i> )	380
Sensor Tamper ( <i>sensor number</i> )	137
Sensor Tamper Restore ( <i>sensor number</i> )	137
Sensor Bypass ( <i>sensor number</i> )	570
Bypass Restore ( <i>sensor number</i> )	570
Sensor Inactivity	391
Late To Close	454
Forced Door	423

## 6.18 Advanced Programming, Action Groups

Reserved: Future content.

## 6.19 Advanced Programming, Scenes

Click the Advanced bar and select **Scenes** from the menu to program scenes options.

Scenes Submenus

### 1 Scene Number (1 – 16)

\Scenes\Scene Number: 1 Scene ▼

Scene Name

When Should Scene Work

Scene Trigger Type

Activate Sensor

Scene Results

The system can support a total of 16 Scenes. Each Scene is identified by a unique number, which cannot be altered, and remains the key reference for each Scene.

### 3 When Scene Should Work

\Scenes\Scene Number: 1 Scene ▼

When Should Scene Work

Always On ▼

Select the Schedule that controls when this Scene is active. If the current date and time is outside of the selected schedule, then the Scene will not run.

### 2 Scene Name

\Scenes\Scene Number: 1 Scene ▼

Scene Name

Each group can be configured with a custom 32 character name. The name is displayed wherever an Action Group is referenced on the system.

### 4 Scene Trigger Type List

\Scenes\Scene Number: 1 Scene ▼

Scene Trigger Type

Disable ▼

Disable

Sensor Open

Sensor Not Open

Sensor Alarm

Area Armed Away

Area Armed + Bypass

Area Armed Stay

Area Not Armed Away

Entry Delay

Exit Delay 1

Exit Delay 2

Area Sensor Bypass

Area Tamper

Area Not Ready to Arm

Area Sensor Low Battery

Area Sensor Supervision Fault

Area Alarm

Area Burg Alarm

Area Fire Alarm

Area Panic Alarm

Area Auxiliary Alarm

Area Siren

Area Fire Siren

User PIN entered

Action Function True

Action Function False

Schedule Activated

Schedule Deactivated

Smoke Power Reset

Turn On By User

Turn Off By User

Geo Radius Entered

Geo Radius Exited

Siren On

Z-Wave Devices (Beta)

Select the event that will trigger the Scene.

**Note:** If you want to trigger a scene with:

- User PIN entered
- Turn On By User
- Turn Off By User

you must first enable Log PIN Use.

To enable, see [Permission Options](#).

Scenes Submenus

### 5 Activate Sensor

\Scenes\Scene Number: 1 Scene ▾

Activate Sensor disabled ▾

Select which sensor will provide the trigger for the Scene.

### 6 Scene Results Number/ Device

\Scenes\Scene Number\Scene Results\Scene Result Number: 1 Scene ▾

1 Scene Result Number ▾  
Device

Each scene can trigger up to 16 scene actions when a certain condition is met. A scene can be triggered manually, through a schedule, or via a system event. These are simplified actions that allow you to control devices on your system. There are two types of Scene Action - Alarm System Action and Z-Wave Device Action.

1. Alarm System Action
2. Result Type - The event of the Action Result to perform. Reference the Scene Action and Scene Action Events Types table below.
3. Result Number - Select the area / scene / camera number to control.

#### 1. Z-Wave Device Action

To display Z-Wave Action Types you must first learn in a Z-Wave device. The Z-Wave device name will then appear.

2. Device – select the Z-Wave device you want to control.
3. Z-Wave Type 8 Setting 1 – depends on Z-Wave device. May include options such as On, Off, Heat, Cool, Auto, Up, Down, Lock, Unlock.

Scene Action	Action Event Type
<b>Alarm System Action</b>	Disabled Sensor Bypass Turn On Away Turn Off Armed Stay Reset AutoArm Timer Armed Away, No Auto Stay Chime On Chime Off Activate Scene Trigger Camera Video Clip
<b>Z-Wave Device Action</b>	The available functions depend on the Z-Wave device(s) installed. Here are some examples:  Disabled On Off Heat Cool Auto Cool Set Point Heat Set Point Lock Unlock

## 6.20 Advanced Programming, Speech Tokens

Reserved: Future content.

## 6.21 Advanced Programming, Cameras

Click the Advanced bar and select **Cameras** from the menu to program camera options.

### Add a Camera Method 2 – Manual Entry

1. Enter a name for the camera.
2. Enter the IP address and MAC address (Submenus 3, 4 below).
3. Press **Save**.
4. Your camera will now be viewable from the Web Server and UltraSync app.

### C a m e r a s   S u b m e n u s

C a m e r a s   S u b m e n u s

#### 1 Camera Number (1-16)

\Cameras\Camera Number: 1 Camera ▼

Camera Name  
LAN IP Address  
MAC Address

Choose the Camera Number

#### 2 Camera Name

\Cameras\Camera Number: 1 Camera ▼

Camera Name

Assign Camera Number a Name

#### 3 Camera LAN IP Address

\Cameras\Camera Number\LAN IP Address:

LAN IP Address 1 Camera ▼

Assign a Camera a LAN IP address

#### 4 Camera MAC Address

\Cameras\Camera Number: 1 Camera ▼

MAC Address

Assign a Camera a MAC address

### Removing a Camera

1. Select the camera you wish to remove.
2. Delete the IP address and MAC address (Submenus 3, 4 above).
3. Press **Save**.
4. Your camera will no longer be accessible from the system.

## 6.22 Advanced Programming, Network Servers

Click the Advanced bar and select **Network Servers** from the menu to program network server options.

The system will establish a secure VPN connection to Network Servers to allow simplified set up and configuration of email reporting and remote access features.

The server addresses are pre-programmed and **SHOULD NOT** be modified unless you are instructed to by technical support staff.

Network Servers Submenus

**1** Passcode and Servers

\Network Servers:  
Web Access Passcode  
Ethernet Server 1  
Ethernet Server 2  
Ethernet Server 3  
Ethernet Server 4  
Cellular Server 1  
Cellular Server 2  
Cellular Server 3  
Cellular Server 4

**3** Ethernet Servers (1-4)

\Network Servers:  
Ethernet Server 1

Ethernet Server 1 -  
The IP address or server name of the primary Ethernet server.

Ethernet Servers 2 - 4  
The IP address or server names of the backup Ethernet servers.

**2** Web Access Passcode

\Network Servers:  
Web Access Passcode

This 8 digit code is required to allow remote access to your system via a smartphone app. Set this to 00000000 to disable this feature.

**4** Cellular Servers

\Network Servers:  
Cellular Server 4

Cellular Server 1 -  
The IP address or server name of the primary wireless server.

Cellular Servers 2 - 4  
The IP address or server names of the backup cellular servers.

**C** 174 P/N 466-5261 • REVA • ISS 10JAN17

UltraSync Modular Hub Reference Manual

©2017 United Technologies Corporation **I**







## 7 Users and Permissions

A user is a system operator that is granted the authority to control and or configure the system. The Users menu is where you add, delete or modify one of the 256 users. Each user is assigned a PIN code and a user number. This allows them to interact with the system.

Users will typically interact with the system via a keypad or wireless keyfob(s) for tasks such as arming and disarming an area, bypassing a sensor. Permissions can be granted to a user to perform tasks such as adding sensors, modifying schedules or deleting users.

Users can only edit users with the same or less authority than them. If a user attempts to access a user with a higher level of access (e.g. to more menus or more areas) then the system will deny access.

### 7.1 Add Users

Connect to the Web Server. The login screen should appear:

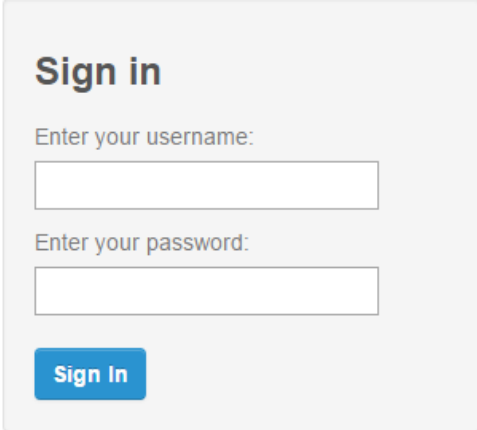

Enter your username and password. A master User PIN is required to add users, by default this is “**User 1**” and “**1-2-3-4**”, then press **Sign In**.

Press **Users**. The following screen appears:

User Menu:

Select User  Sort By Name

User 1 (1) ▼

User Number: 1

First Name: User 1

Last Name:

PIN: 1234

Language: English ▼

User Type: Master ▼

Area Group: All Areas ▼

Display Area List:

Area Type Override:

Start: 01/01/2000 Midnight ▼

End: 02/07/2106 6:00 AM ▼

Enter a First and/or Last Name.

Enter a unique PIN code between 4 and 8 digits.

Select a User Type:

- **Standard users** can arm and disarm areas; they cannot create users or review event history.
- **Master users** can arm and disarm areas. They can create, delete, or modify user codes. They can also change system settings.
- **Arm Only users** can only turn on the security system; they cannot disarm, or dismiss any system conditions.
- **Duress users** will send a duress event when they are used to arm or disarm the system.
- **Custom users** can have additional permissions and settings configured.
- **Language** Select the language displayed for this user
- **Display Area List** When this feature is enabled on a multi-area system and this user requests to arm/disarm the system from the main screen of the keypad, the keypad will display the area control screen that will allow them to arm individual areas. If this feature is disabled, the keypad will automatically arm/disarm all areas.

Press **Save**.

## 7.2 Users Submenus

The following submenus describe the features associated with the Users Menu.

User Submenus

Select User Sort By Name

User Number

First Name

Last Name

PIN

User Type

Start:

End:

Profile 1:

Profile 2:

Profile 3:

Profile 4:

User Submenus

**User First Name**

Each user can be configured with a custom 16 character first name. The user name descriptor may be displayed in the event log, keypad and when remotely connected to the system via the management software.

**User Last Name**

Each user can be configured with a custom 16 character last name. The user name descriptor may be displayed in the event log, keypad and when remotely connected to the system via the management software.

**User Number**

The system will store a number of users relative to the model type and the amount of memory installed. Unlike other systems, user numbers are not predefined and can be configured from user number 1 to 1000 as long as user numbers are not duplicated and do not exceed the total number of users that can fit the allocated memory.

**User PIN**

Users can be configured with 4 to 8 digit PIN. The user PIN is required by the system to determine the user number and the users associated permissions system control and configuration. Any number of users can have any digit length from 4 to 8 digits.

**User Type**

User Type provides quick configuration of user permissions. The available user types are:

**Standard** – Standard users can only change their own PIN codes and cannot change the settings of the system. They can arm and disarm areas to which they have access.

**Master** – Master users can change Standard user PIN codes and Master user PIN codes, and can access all menus except installation programming.

**Arm Only** – Users can only arm selected areas.

**Duress** – Duress code will send a duress report to the specified Channel Groups under System Event Reporting. The duress code does not trigger an audible alarm.

**Custom** – The system will apply user permissions and user permission schedules. This requires advanced programming. A Custom user is able to modify the configuration of themselves or another user if:

Permission Option 'Remote Access' is enabled (for web page access).

Permission Menu 'Users' is enabled to allow them to assign user permissions.

Otherwise they will only be able to change their own PIN code. They have area access to at least one area of the user being modified. This does not check permission options.

## 7.3 Permissions

There are a total 128 unique permissions that can be configured in the Permissions menu. Once configured any permission number from 1 to 128 can be allocated in this feature (user permissions 1).

User permissions determine what level of access and functionality a user has when interacting with the system. This includes what menus they can see, what areas they can see, areas they can arm / disarm / reset, perform special area functions of timed disarm / man down / guard tour, what actions they can use, and what channel to report on.

Combining a user permission with a user permission schedule will determine when that user has that level of access and functionality. The system allows each user to be allocated with up to 4 user permissions and permission schedules. This provides a high level of flexibility and user permissions can change based on time and date, or even certain system conditions when combined with actions.

When any user permission is active, it overrides any user type. This means a permission can increase or decrease access when it is active. If a user is not assigned any permissions (i.e. permission set to "Disabled"), then the User Type setting is used to determine what the user can do.

## Permission Schedule 1

The system's permission schedules determine when to allocate user permissions to a user.

User permissions are numbered from 1 to 4 where permission 1 is the highest priority and permission 4 is the lowest priority. If user permission 1 schedule is not valid then user permission 2, 3 and 4 are checked in sequence until a valid schedule can be applied.

Higher priority permissions replace lower priority level permissions when they become active. Only one permission can be active at any time. Permissions have a logic OR function.

**IMPORTANT:** If permission 1 is active due to a valid schedule, permission 2 will never become active. Make sure to assign/program permissions in the right order.

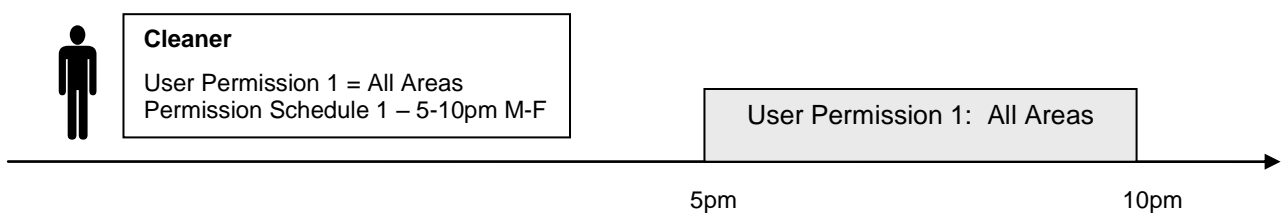

A cleaner is given access to all areas after hours. They can disarm/arm the security system from 5pm to 10pm on weekdays. They have no access outside of these times and days.

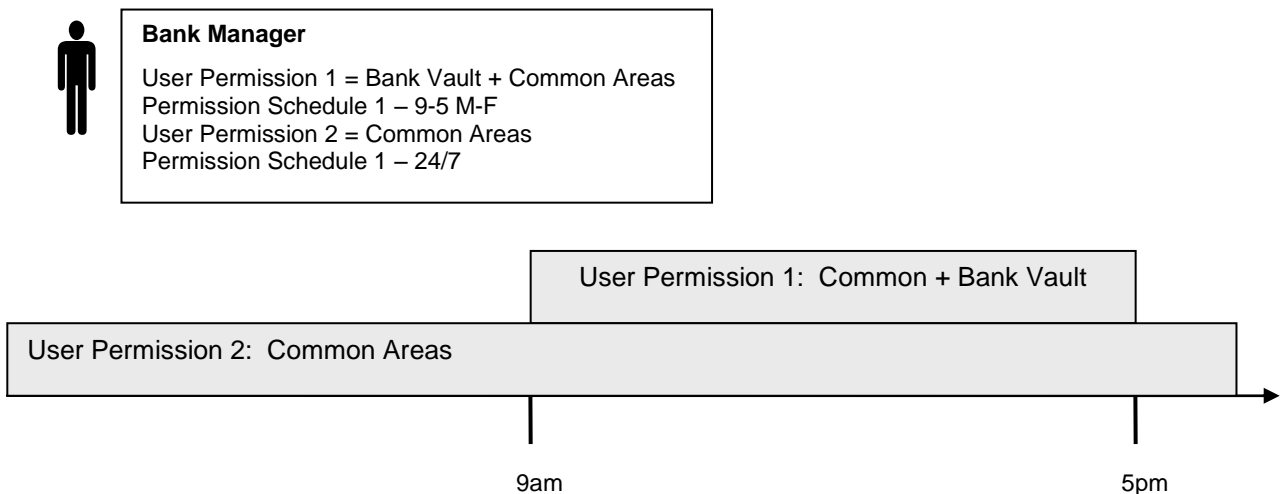

A bank manager has access to the common areas of the bank 24 hours a day. During office hours they have access to the bank vault as well. The permissions to access bank vault become active at 9am, overriding the common areas permission. When the time becomes 5pm the bank vault permissions become inactive and their lower level permissions to access the common areas become active again.

**IMPORTANT:** Only one permission can be active at any one time. User Permission 1 overrides User Permission 2, so ensure User Permission 1 includes all the areas (and other features) you want to give access to. If User Permission 1 only included the Bank Vault, the user would NOT have access to the Common Areas.

	Arm Only	Standard	Master	Engineer	Master Engineer	Custom User
Change their own PIN code	X	X	X	X	X	Custom
Arm areas based on permissions	X	X	X	X	X	Custom
Disarm areas based on permissions		X	X	Limited	X	Custom
Can create and modify Standard users			X		X	Custom
Program installation settings				X	X	Custom
Can create and modify Engineer users					X	
Can create custom permissions and schedules						X

### Area Group

When a non-Custom User Type is selected, this setting determines what areas that user has access to.

When a Custom User Type is selected, permissions will be used instead of this Area Group setting.

### Start Date

The first date when this user can interact with the system. Future start dates can also be set here. The user will only be able to interact with the system between the start date and end date.

### End Date

The last date when this user can interact with the system. Future end dates can also be set here. The user will only be able to interact with the system between the start date and end date.

### Language

Currently English is the only supported language.

## 8 Expansion Module Installation

These instructions are common to Zone or Relay Expansion Modules

1. Open the alarm panel.
2. Pull down the din rail tab on the bottom of the module. (Pictured: UM-Z8)

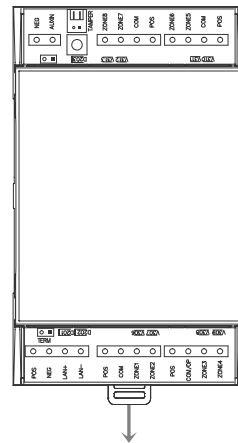
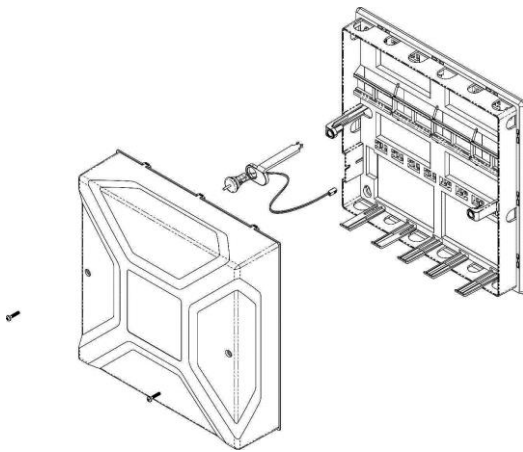

3. Hang the module on the top of the din rail, tilting the bottom of the module outward. Once the module is vertical, lock the module on the rail by pushing the tab up.
4. Connect BUS and power off the CPU

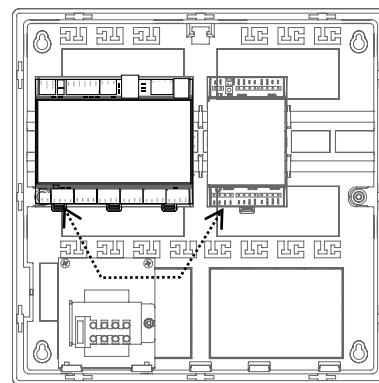
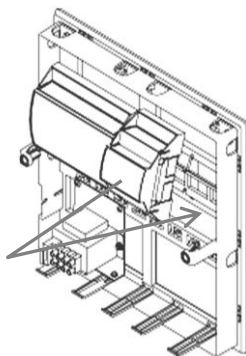

- Correct RS-485 termination reduces communication issues with signal reflections. For a single long cable run, put a jumper across the terminal labeled **TERM** on the **CPU** and the **furthest** bus device. For installations with multiple long cable runs, do not place a terminator on the CPU; rather place one at the end of each of the **two longest** cable runs.

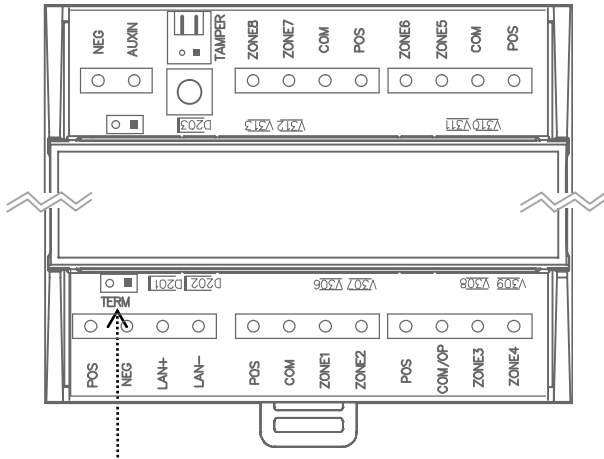

- Enroll the expansion module in your system. To manually enroll the module, use the web interface. In the advanced menu, navigate to **Devices – System Devices – Control – Enroll Function** and select Manual Enroll from the drop down menu. This puts the system into the manual enrollment mode and waits for you to push the enrollment button on the expansion module. Hold the button down for three seconds. (Pictured: UM-Z8)

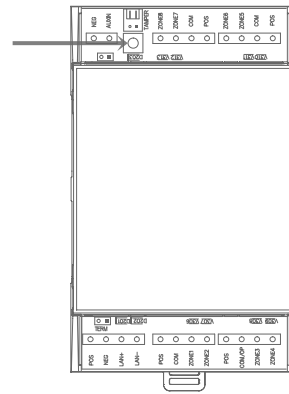

- For enrollment options see Section 6.9, [Advanced Programming, Devices and Enrollment](#)
- When connecting powered sensors you can use the zone expansion module's POS and COM terminals for power. Powered sensor current draw must be accounted for in your overall system power budget calculations. Refer to the documentation of the powered sensor for current draw specifications.



## 9 Cellular Radio Setup

An optional cellular radio provides a backup reporting path to the central monitoring station over a cellular network if the Ethernet connection is not working. This module adds mobile communication to the alarm panel, allowing alarm reporting and remote connection over the mobile network via the UltraSync Cloud solution.

This provides a plug and play connection to UltraSync servers for secure reporting with no configuration needed in most cases. The only requirement is good mobile device reception. To connect via Cellular Radio you only need to plug in the cellular radio module.

The cellular modem is pre-configured and does not require any programming in the system. However, the system must be provisioned in the UltraSync Portal for cellular reporting per the options below:

Connectivity	Portal Provisioning
Ethernet and Cellular	US Grade 2 dual path
Cellular only	US Grade 2 Cellular

Once plugged onto the panel, the unit will automatically register itself on the cellular network. Please refer the manual that comes with the cellular radio for instructions on how to install it.

### 9.1 Install Optional Cellular Radio

---

**Note:** A SIM card is pre-installed and should not be removed.

---

A mobile device can provide general guidance on mobile network coverage.

Look at the signal strength on a mobile device to verify there are 4/5 to 5/5 bars of reception in the location where you will install the system.



If the signal strength is low, find another location which has stronger signal strength.

---

**Note:** Actual signal strength can only be determined logging in to the panel.

---

If a cellular module is pre-installed on the CPU, skip to the Check Network Coverage section. If not, remove the cover by releasing the four (4) side clips with a flat blade screwdriver.

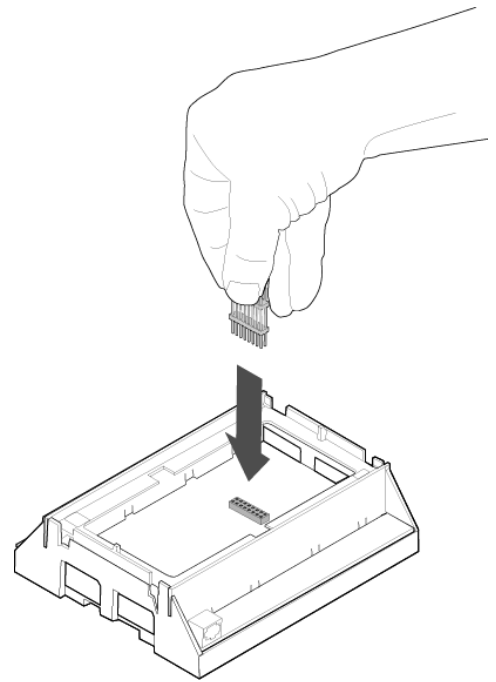
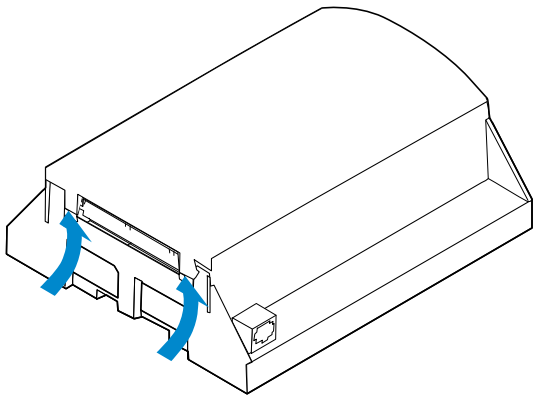

Locate the 16-pin header on the main board and insert the board-to-board connector.

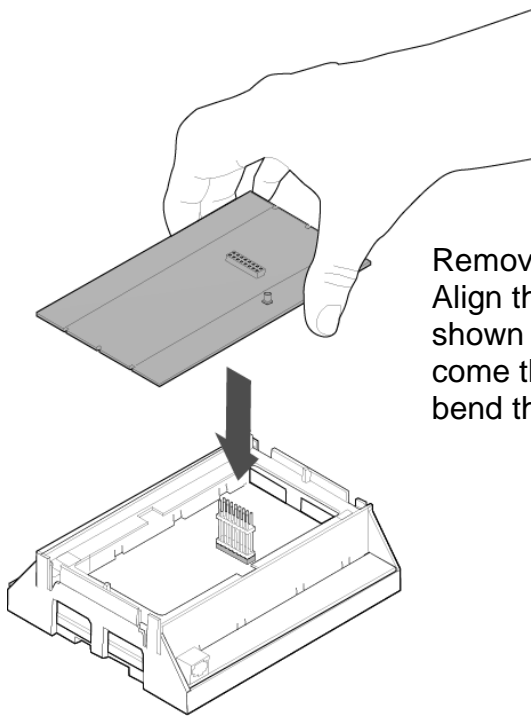

Remove the 3G module from the packaging. Align the 3G module on the 16-pin header as shown to the left. Push down until the pins come through the header. Take care not to bend the pins.

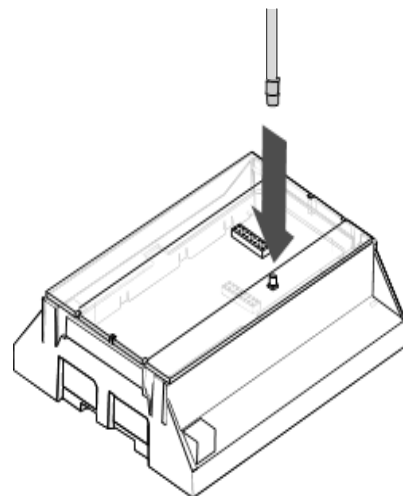

Install the antenna by aligning the connector and pressing down until you hear a “click”.

Align the smaller cover included with the UM-C-H1 and press down until all four (4) clips lock into place. The original larger cover is no longer of use at this stage. For future reference you may want to peel off the serial number bar code label from the original cover and place it on the smaller cover just installed

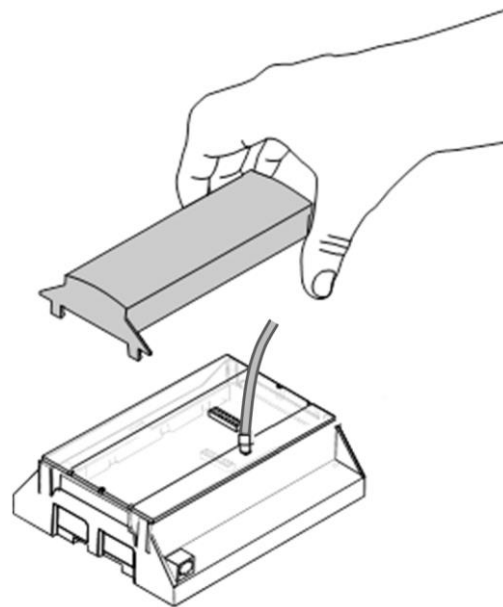

## 9.2 Check Signal Strength

This chart illustrates the acceptable signal strength range.

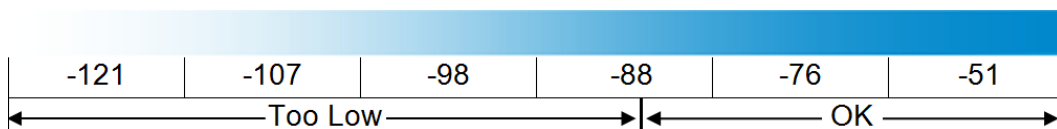

- If the reported value is -88 to -51 then the signal strength is OK.
- If the reported value is -121 to -89 then relocate the antenna until the signal strength is in an acceptable range.

To check the signal strength using the UltraSync web server or the UltraSync app: Login to the UltraSync Web Server, and click Settings – **Connection Status**. Scroll down to Signal Strength and check whether Signal Strength is acceptable.

Settings Selector

Connection Status ▾

Up
Down
Reload

Connection Status

LAN Status Connected

Cell State Connected ←

UltraAgent Wired Idle

UltraAgent Wireless Idle

UltraConnect Status Idle

UltraConnect Media LAN

Cell Service Valid Service

Radio Details

Signal Strength -74 ←

Operator ID

Radio Technology GSM

Device UID (Serial) 741299454728

Check cellular connection:

- a. Look at cell state, it should display **Connected**.
- b. Wait until cell state displays **Connected**, press **Reload** to refresh the status.
- c. Check signal strength – signal strength should be between -88 to -51.
- d. Contact Tech Support for assistance.
- e. Check that radio is correctly installed and firmly connected.
- f. Check if antenna is correctly installed or move antenna to a higher location.

If you need to make changes, open the UltraSync Web Server and go to:

**Advanced – Communicator – Cellular configuration:**

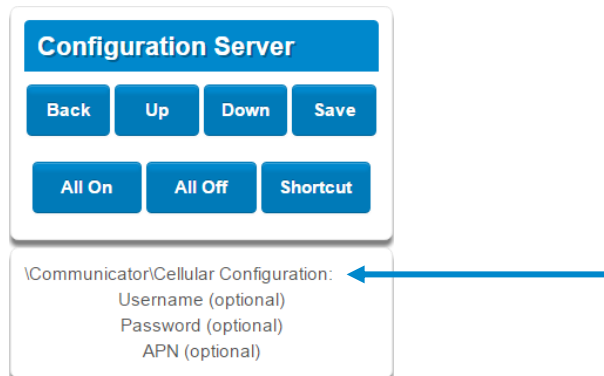

Only change these settings as instructed by your supplier or telecommunications provider.

*To check the signal strength via the UM-1820E keypad:*

Press **MENU** – **[PIN code]** – **Settings** – **Status** – **Connection Status**.

Scroll Right **▶** until you see Signal Strength.

Check whether Signal Strength is acceptable.

### 9.3 Check cellular connection to UltraSync servers

1. Login to the Web Server as shown above.
2. Click Settings.
3. Select Connection Status in the drop down menu.
4. Check:
  - UltraSync Status should display “Connected”.
  - Cell Service should display “Valid service”.
  - Signal Strength should display a value. See Section 9.2 to [Check Signal Strength](#).

The screenshot shows a web interface with a 'Settings Selector' header. Below it is a dropdown menu for 'Connection Status' and three buttons: 'Up', 'Down', and 'Reload'. The main content is divided into two sections: 'Connection Status' and 'Cellular Radio Details'. The 'Connection Status' section includes fields for 'LAN Status' (Connected), 'UltraSync Status' (Making Connection), and 'UltraSync Path' (IP). The 'Cellular Radio Details' section includes fields for 'Cellular State' (Idle), 'Cellular Service' (No service), 'Signal Strength' (0), 'Operator ID', and 'Radio Technology' (GSM). Three blue arrows point to the 'UltraSync Status', 'Cellular Service', and 'Signal Strength' fields.

If it does not display a signal strength value, check the cellular connection:

1. Check Settings – Network – Enable UltraSync is checked.  
Alternatively from a keypad press MENU – Program – Communicator – IP Configuration – IP Options – Enable UltraSync: Y.
2. Look at Cell State, it should display “Connected”. Please wait until Cell State displays “Connected”, click Reload to refresh the status.
3. Signal strength should be between -89 to -51.
4. Check cellular radio module is correctly installed.
5. Check cellular radio antenna is correctly installed or move antenna to a new location with better signal strength.

Congratulations, your system is connected to UltraSync. It is now ready to be programmed.



## 10 UltraSync Touchscreen Setup

### 10.1 Quick Setup

1. Connect Power Lead to the touchscreen.
2. Connect the micro-USB connector from power supply to the micro-USB port of the touchscreen.

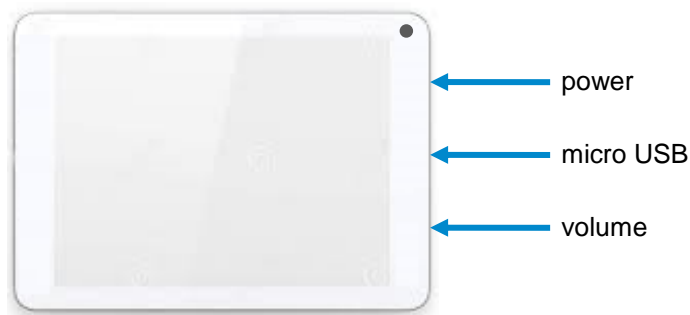

3. Power up

Hold the power button on the touchscreen. The screen will light up.

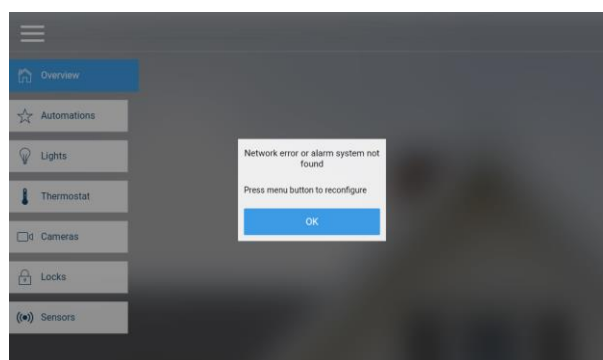

4. On the first startup, you will see a network error message because the touchscreen is not connected to a Wi Fi network. Press OK. Press the menu button to configure the touchscreen. The touchscreen will ask you for a PIN.

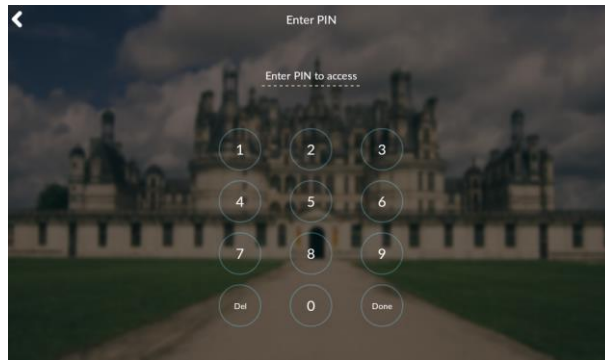

5. Enter the default installer PIN of the touchscreen, which is **9-7-1-3**. Then press **Done**.

6. Press the settings button.



## 10.2 Set up Wi Fi

1. Press Wi Fi.

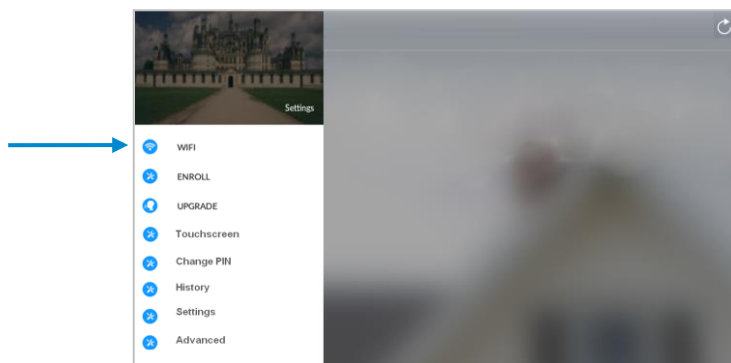

2. Select a Wi Fi network from the list that appears. Press the network you wish to use.



**!! Note:** The touchscreen and hub must be on the same network. **!!**

3. Type in the network password and press connect.

4. Once connected to Wi Fi, you will be brought back to the main screen..



## 10.3 Enroll the Touchscreen

1. The touchscreen needs to be enrolled into the UltraSync Hub. Press the menu button and press enroll.

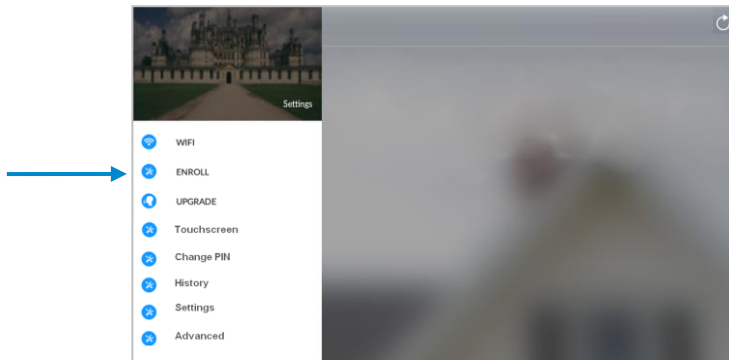

2. The touchscreen will automatically find any available hubs on the network. They appear in the left column. Select the desired hub from the network displayed. Enter the installer PIN that is set up for the hub. **Note:** This may not be the default **9-7-1-3**.

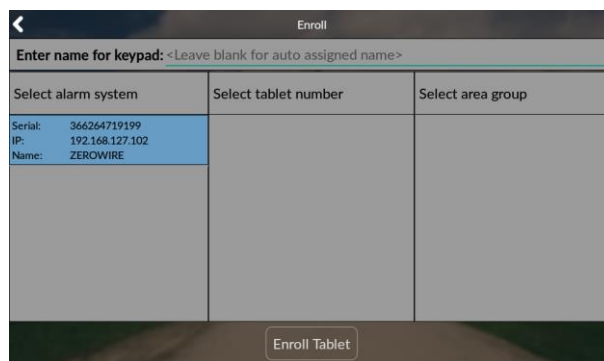

3. Select an available tablet number space (center column). Then select the area group you wish the touchscreen to control (right column).

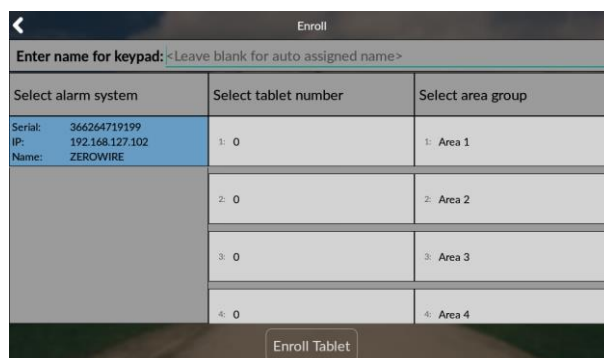

4. Press the **Enroll Tablet** button at the bottom of the screen.

## 10.4 Touchscreen Settings

**Allow Master User to Upgrade Firmware** – Enable this feature to allow the Master User to have access to the Upgrade menu.

**Language** – This allows you to select the language the touchscreen displays.

**Active Brightness** – Choose between 1% - 100%. This is the background light level when the user is actively using the touchscreen.

**Idle Brightness** – Choose between 1% - 100%. This is the background light level when the user is not actively using the touchscreen. Setting the level to 1% will make the touchscreen appear black when idle. The user may still touch the screen to make the screen active again.

**Idle Timeout** – Choose between 10 – 300 seconds. This is the amount of time that touchscreen allows the user to be idle before it locks down and requires a PIN to re-enter the touchscreen.

**Beep Volume** – Choose between 1% - 100%. This is the volume level of entry/exit beeps.

**Camera User Name and Camera Password** – If using the touchscreen with cameras, you must enter the camera's User Name and Password to allow access.

## 10.5 Mounting

1. Mount the wall bracket in the desired location using the supplies wall anchors and screws.

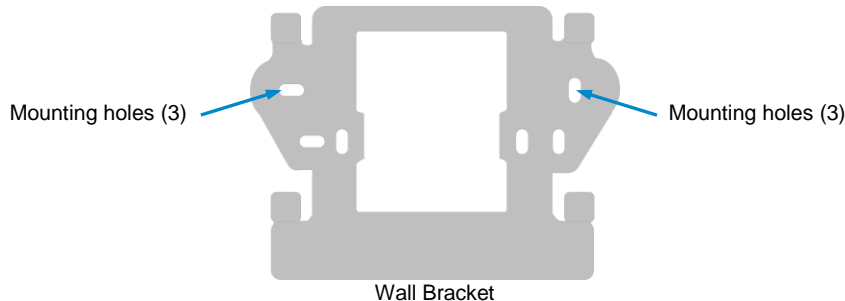

2. Notice the mounting tabs; they slide into slots on the back of the tablet.

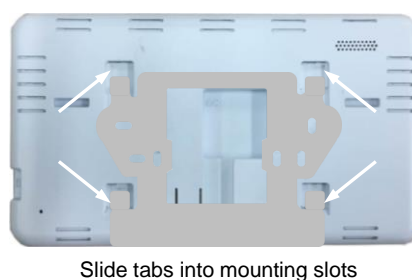
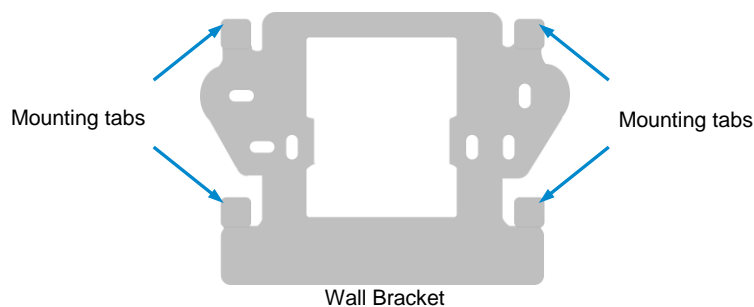

3. To remove the tablet from the mounting bracket, use a small screwdriver to push up on the release tab on the bottom of the tablet's back cover.

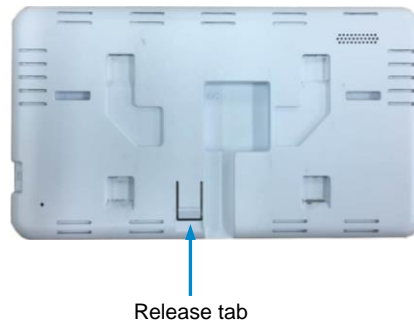

## 10.6 Upgrading Firmware

1. Always upgrade your touchscreen to the latest firmware during the first startup.

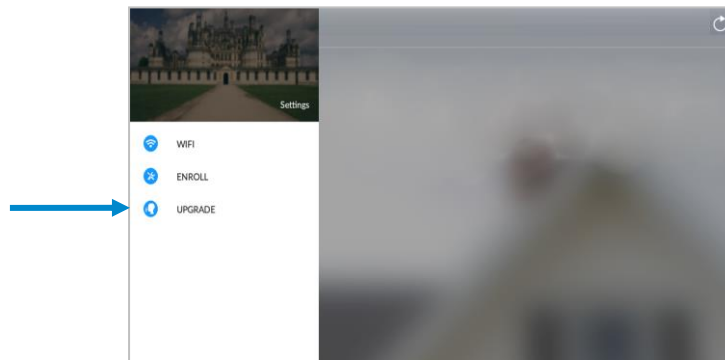

2. If firmware is available, press **Download**. Wait until the download is complete. Press **Install**; you will be returned to the main screen

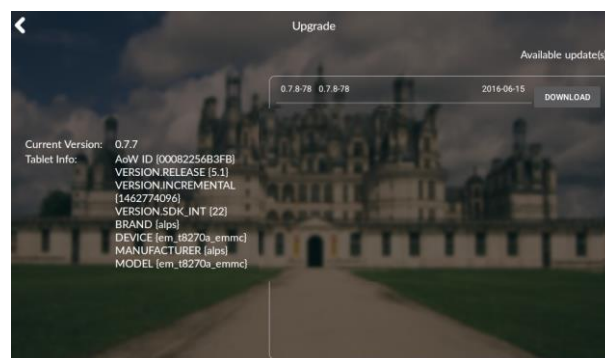

## 10.7 Other

1. To increase speed and performance, the UltraSync touchscreen communicates with the cameras using the local network. If you have modified the cameras' usernames or passwords you must enter these updated credentials in the touchscreen.



## 11 Camera Setup Instructions

### 11.1 Quick Setup

---

**Note:** If the light source where the camera is installed experiences rapid, wide variations in lighting, the camera may not operate as intended.

---

**To quickly put the camera into operation:**

1. Prepare the mounting surface.
2. Mount the camera using the appropriate fasteners.
3. Connect the camera to the local network via Ethernet cable or Wi Fi..
4. Learn the camera into the UltraSync App using the “Scan for New Cameras” button discussed in Section 5.10, [Camera Configuration](#).

### 11.2 Setting up Ethernet/Wi Fi transmission

**Wi Fi transmission distance**

The Wi Fi transmission distance/range of the camera is approximately 50 m (164 ft.) in open air applications.

---

**Note:** The transmission distance may vary due to the presence of physical obstacles, such as trees, walls, elevators, fire doors, furniture, etc. Avoid very solid walls and metallic objects in the transmission path. Other Wi Fi networks (for example Wi Fi, WiMAX) operating on 2.4 GHz and certain types of devices (e.g., microwave oven point-to-point Wi Fi transmission) can cause interference with your network. The result would lead to a reduction in transmission distance/range.

---

**Devices Supported For Ad Hoc Installation**

Apple iOS, PC – Windows XP, 7, 8

**Devices NOT Supported For Ad Hoc Installation**

Android, Windows Mobile, Blackberry

## 11.3 Wi Fi Signal Strength

Wi Fi signal strength can be checked in the Network section of the TruVision Browser. Use the scale below to measure if actions are needed to improve performance.



>65 Poor	65-75 Good	75-85 Very Good	85+ Excellent
-------------	---------------	--------------------	------------------

### **85+ – Excellent:**

No additional actions needed and default video resolutions settings may be increased if desired.

### **75-85 – Very Good:**

No additional actions needed to increase signal strength. It is not recommended to increase video resolution settings.

### **65-75 – Good:**

It is recommended to use a Wi Fi repeater or Powerline adapter to increase signal strength. Alternatively, video resolutions settings may be reduced to minimize poor video quality.

### **Below 65 – Poor:**

It is not recommended to use the camera with a signal strength below 65. Video streams will likely not work below this level. A Wi Fi repeater or Powerline adapter should be used to increase signal strength.

## 11.4 Add Camera via Wi Fi for iOS Device

1. Power up the camera. (Boot up may take 1-2 minutes)
2. From your iOS device, go to **Settings**, then **Wi Fi**.
3. Find and select TVW-xxxxx. (Listed under Devices)
4. Once connected, press the info circle on the right of TVW-xxxxx.
5. Under IP Address, press **Static** and enter the info below.
  - a) IP Address **192.168.1.71**
  - b) Subnet Mask **255.255.255.0**
6. Open Mobile Browser. (Safari)
7. Enter the camera's default IP Address into the address bar.
  - a) **192.168.1.70**
8. TruVision Configurator will appear. Enter Credentials below.
  - a) User Name: **admin**
  - b) Password: **1234**
9. Press **Configuration** on the top menu.
10. Press **Network** on the left menu.
11. Press **Wi Fi** on the middle tab.
12. Select your network from the Wireless List.
13. Enter Wi Fi Network Passphrase in **Key 1** Section.
14. Press **Save** on the bottom of the screen.

**You are now connected to the network via Wi Fi!**

## 11.5 Add Camera via Wi Fi for Windows PC

1. Power up the camera. (Boot up may take 1-2 minutes)
2. From your Windows PC, Find and connect to TVW-xxxxx in Wi Fi network list.
3. Go to **Network and Sharing Center**.  
**Control Panel > Network and Internet > Network and Sharing Center**
4. Press Change Adapter Settings on left.
5. Right click **Wireless Network Connection** and select **Properties**.
6. Click Internet Protocol Version 4 (TCP/IPv4) and click Properties.
7. Click "Use the following IP address", enter the info below, and then click OK.
  - a) IP address: **192.168.1.71**
  - b) Subnet mask: **255.255.255.0**
8. Open Browser (Firefox, Chrome, IE8) and enter the camera's IP Address into the browser's address bar.
  - a) Camera's Default IP Address is **192.168.1.70**.
9. TruVision Configurator will appear. Enter Credentials below.
  - a) User Name: **admin**
  - b) Password: **1234**
10. Click **Configuration** on the top menu.
11. Click **Network** on the left menu.
12. Click **Wi Fi** on the middle tab.
13. Select your network from the **Wireless List**.
14. Enter Wi Fi Network Passphrase in **Key 1** Section.
15. Click **Save** on the bottom of the screen.

**You are now connected to the network via Wi Fi!**

## 11.6 Add Camera via Ethernet for iOS Device (non DHCP)

1. Power up the camera. (Boot up may take 1-2 minutes)
2. From your iOS device, go to **Settings**, then **Wi Fi**.
3. Find and select TVW-xxxxx. (Listed under Devices)
4. Once connected, press the info circle on the right of TVW-xxxxx.
5. Under IP Address, press **Static** and enter the info below.
  - a) IP Address               **192.168.1.71**
  - b) Subnet Mask           **255.255.255.0**
6. Open Mobile Browser. (Safari)
7. Enter the camera's default IP Address into the address bar.
  - a) **192.168.1.70**
8. TruVision Configurator will appear. Enter Credentials below.
  - a) User Name:   **admin**
  - b) Password:   **1234**
9. Press **Configuration** on the top menu.
10. Press **Network** on the left menu.
11. Change LAN settings to desired configuration.
  - a) Change the **IPv4 Address** and **IPv4 Subnet Mask** to match the router if a static IP Address is desired.
    - i. You must change the static IP address to something different than the default 192.168.1.70 if more than one camera is used on the network.
    - ii. Make sure to use the Test button to validate IP Address is not already assigned to another device in the network.
12. Press **Save** on the bottom of the screen.

**You are now connected to the network via Ethernet!**



## 11.7 Add Camera via Ethernet for Windows PC (non DHCP)

1. Power up the camera. (Boot up may take 1-2 minutes)
2. From your Windows PC, Find and connect to **TVW-xxxxx** in Wi Fi network list.
3. Go to **Network and Sharing Center**.  
**Control Panel > Network and Internet > Network and Sharing Center**
4. Click Change Adapter Settings on left.
5. Right click **Wireless Network Connection** and select **Properties**.
6. Click Internet Protocol Version 4 (TCP/IPv4) and click Properties.
7. Click "Use the following IP address", enter the info below, and then click OK.
  - a) IP address: 192.168.1.71
  - b) Subnet mask: 255.255.255.0
8. Open Browser (Firefox, Chrome, IE8) and enter the camera's IP Address into the browser's address bar.
  - a) Camera's Default IP Address is **192.168.1.70**.
9. TruVision Configurator will appear. Enter Credentials below.
  - a) User Name: **admin**
  - b) Password: **1234**
10. Click **Configuration** on the top menu.
11. Click **Network** on the left menu.
12. Change LAN settings to desired configuration.
  - a) Change the **IPv4 Address** and **IPv4 Subnet Mask** to match the router if a static IP Address is desired.
    - i. You must change the static IP address to something different than the default 192.168.1.70 if more than one camera is used on the network.
    - ii. Make sure to use the Test button to validate IP Address is not already assigned to another device in the network.
13. Click **Save** on the bottom of the screen.

**You are now connected to the network via Wi Fi!**

## 11.8 Add Camera via Ethernet (DHCP)

1. Power up the camera. (Boot up may take 1-2 minutes)
2. Connect router and camera with Ethernet cable.  
**You are now connected to the network via Ethernet!**

## 11.9 Add Camera to UltraSync

Ensure proper installation of camera hardware before proceeding to camera setup.

**Make sure camera and UltraSecure intrusion panel are on the same local area network.** Applications where the Intrusion panels uses cellular only are not compatible with this camera.

---

**Note:** For detailed information on how to setup the UltraSync app, add locations, and login as an Installer, reference the intrusion panel installation guide.

---

Press  then  for the **Settings Selector** page.

Select **Cameras** from the drop down menu.

Press **Scan for New Cameras**. “Success!” message will pop-up after a few moments. The scan results in an IP address and MAC address listing in the form fields shown.

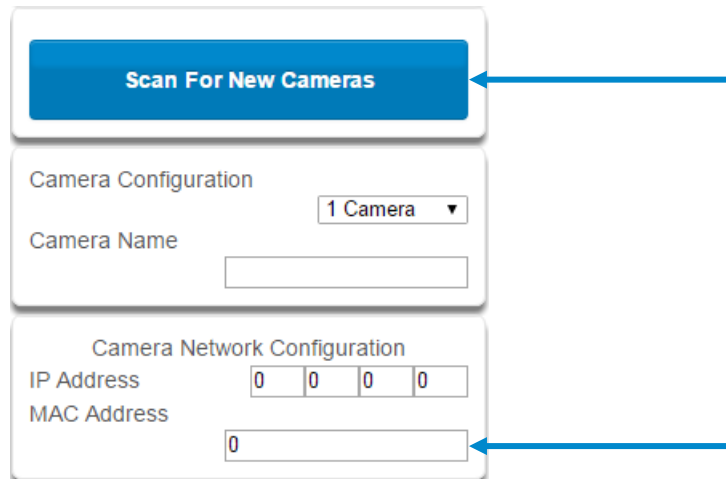

The screenshot shows a configuration form with three main sections. The top section is a blue button labeled "Scan For New Cameras". Below it is the "Camera Configuration" section, which includes a dropdown menu set to "1 Camera" and a "Camera Name" text input field. The bottom section is "Camera Network Configuration", which includes an "IP Address" field with four input boxes each containing "0", and a "MAC Address" field with a single input box containing "0". Two blue arrows point to the "Scan For New Cameras" button and the "MAC Address" field.

Make sure the MAC ID that is automatically populated in the **MAC Address** field matches the MAC Address printed on the back of the camera. If not, change in the MAC Address to the one listed on the back of the Camera.

Press **Save**.

---

**Note:** Camera may take up to 1-2 minutes to finalize association with intrusion panel and show in cameras tab.

---

***CONGRATULATIONS! You have now added the camera to UltraSync!***

## 11.10 View Live Stream and Latest Clip

Press  tab on bottom of the screen. All available cameras will be shown.

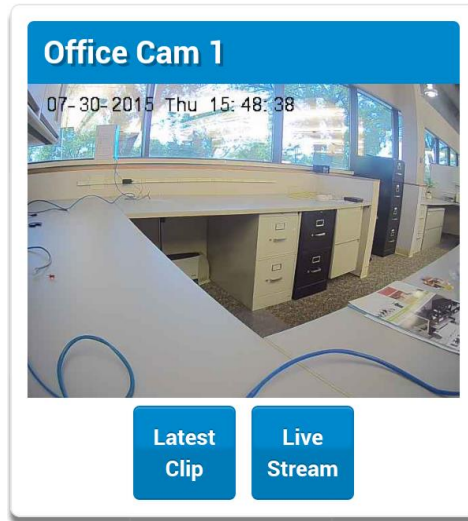

Press  to view a live feed of a specific camera.

Press  to view the last recorded clip from a specific camera.

## 11.11 Program Event Triggered Camera Clips

Cameras can be programmed to automatically record when selected events occur. This is achieved by creating a scene.

Press  then  for the **Settings Selector** page.

Select **Automation (Scenes)** from the drop down menu.

1. Select the **Scene to Configure** and type **Scene Name**.

Select Scene to Configure: 1 Scene ▼

Scene Name

2. Select the **When Should Scene Work** drop down menu to restrict when the scene will be enabled.

3. Select the event that will trigger the automation using the **Scene Trigger Type** drop down menu. Choices here dynamically change the “Activate” selections.
4. Select **Activate ( - - - - )** to assign what that triggers applies to.

The screenshot shows a configuration interface for a scene trigger. It is divided into several sections:

- Scene Trigger:**
  - When Should Scene Work: Always On
  - Scene Trigger Type: Area Alarm
  - Activate Area: 1 Home
- Scene Result 1:**
  - Device: (1) Alarm System
  - Action Type: Disabled (dropdown menu is open)
- Device:** (This label appears on the left side of the dropdown menu items)
- Device:** (This label appears on the left side of the dropdown menu items)
- Device:** (This label appears on the left side of the dropdown menu items)
- Device:** (This label appears on the left side of the dropdown menu items)
- Scene Result 5:**
  - Device: disabled
- Scene Result 6:**
  - Device: disabled

The dropdown menu for Action Type is open, showing the following options: Disabled, Disabled, Sensor Bypass, Arm Away, Disarm, Arm Stay, Restart AutoArm Timer, Arm Away - No Auto Stay, Chime On, Chime Off, Activate Scene, **Trigger Camera Video Clip** (highlighted with a blue arrow), Send Area Notification, Send Sensor Notification, Send Notification, and Start Siren.

5. Select the **Scene Result**. Choose **Alarm System** in Device.
6. In **Action Type**, select **Trigger Camera Video Clip**
7. Press **Save**.

Clips are recorded on the Micro SD card installed in the camera and are linked to events in History.

See the following page to see how to view event triggered clips.

## 11.12 View event triggered clips in History

Press  on bottom of the screen.

Press .

Find the Event you wish to view using **Oldest**, **Prev**, **Next**, and **Latest** buttons.



Once you find the clip you wish to view, press **Play Video Clip**.



## 11.13 Remove Camera from UltraSync (if needed)

1. Press the **More** tab on the bottom of the Screen.
2. Press **Settings**.
3. Select **Cameras** under Settings Selector.
4. Select the camera you wish to remove.
5. Delete text in Camera **Name**, **IP Address** and **MAC Address**.
6. Press **Save**.

---

**Remove All Cameras Shortcut:** To remove all cameras from UltraSync, go to Advanced Settings and use **SHORTCUT 910.22**.

---

### Reset Camera to Factory Default (if needed)

If needed, the camera can be reset to factory default. Remove the camera cover, then press and hold the RST/WPS button for 20 Seconds.

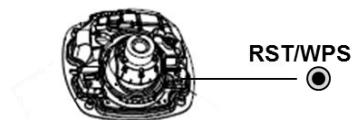

## 11.14 Change Default Camera Settings (Via TruVision Navigator)

1. From a computer or mobile device that is connected on the same network as the camera, type in the IP address of the camera into the devices browser.
2. Login using default login.
  - a. Login: admin
  - b. Password: 1234
3. Change settings as desired such as video quality, frame rate, pre and post recording times.
4. For detailed instructions on using TruVision Navigator, go to [www.interlogix.com/video](http://www.interlogix.com/video).

## 11.15 Camera Troubleshooting

### 1. Camera is not showing in list of Wi Fi networks.

Cause	Solution
The camera takes up to 90 seconds to boot up.	<i>It will not show in Wi Fi Networks until this is complete.</i>
The camera has previously been setup and ad hoc mode was turned off.	<i>Perform a factory reset to broadcast the camera again.</i>
Certain mobile devices do not support ad hoc mode. iOS and Windows devices are known to support ad hoc, Android and Windows Mobile devices typically do not support ad hoc mode.	<i>If your device does not support ad hoc mode, install the camera using a Windows PC.</i>

### 2. The camera does not add to the UltraSync network when I perform the “Scan for Cameras” Function

Cause	Solution
Older firmware versions do not support cameras.	<i>Make sure your panel is updated to the XXXXXX-04 Firmware or new.</i>
The camera will not work if the devices are not on the same network.	<i>Make sure your camera and system are on the same network.</i>
<i>The system</i> must be using IP to work with the cameras.	<i>Make sure your system is not installed using a cellular radio only.</i>
Make sure you are not adding cameras on a network that already has a high number of cameras installed on the same network. This is unusual, but may be common in testing environments.	<i>Put the system and the cameras on their own router and this should solve the problem.</i>

### 3. The camera was added in the setup process, but the video doesn’t show in the Cameras tab.

Cause	Solution
After completing the setup process, the camera may take up to 2 minutes to full sync and show in the UltraSync App.	<i>Wait for the process to complete</i>
	<i>Make sure your camera is still connected to the network.</i>
	<i>If video still doesn’t show, go back into setup and perform the “Scan for Cameras” function again.</i>

### 4. Live Video isn’t giving good quality. It is choppy, shows gray, etc.

Cause	Solution
Check to make sure your camera’s Wi Fi and/or Ethernet connection speeds are not poor.	<i>If Wi Fi connection speeds are poor. It is recommended to use a Wi Fi repeater to increase signal strength.</i>
The cameras default settings are setup to work on a strong home network.	<i>In some cases, low video settings may be required to achieve a smooth video. Use the TruVision Browser to change the cameras video settings.</i>

### 5. Video Clips take a long time to load.

Cause	Solution
The cameras default settings are setup to have video clips start playing in the UltraSync App within 15 seconds (On a strong network). If default settings were changed to longer clip times or higher video quality, the amount of time needed to pull the clip will be higher.	<i>Lower the quality or length of clips to shorten load times.</i>

## 12 Arming and Disarming the System

Only users with an authorized PIN code (Master/Standard Users) will be allowed to use the alarm system.

### 12.1 Keypress Tamper

Disabled by default

When the Enable Idle PIN feature is active, the UM-1820E keypad will be locked in screensaver mode when unused for a preset time. A valid PIN is required to unlock the screen and access the system.

When an incorrect PIN is entered 3 times the keypad is locked for 80 +/- 5 seconds and the screen will display a lock icon. During this time the keypad will not be operational and PIN codes cannot be entered.

After the 80 +/- 5 seconds expires, if the first PIN attempt is incorrect the 80 +/- 5 second timer will start again. If the PIN code is valid, then the counter will reset and a further 2 attempts can be accepted.

### 12.2 Arm Your System in Away Mode

Touch the Away or Away + button to arm your system in Away mode:

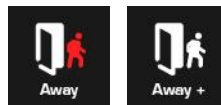

If your system has multi-Area control enabled, the Away + button will be displayed. A valid PIN code will need to be entered to determine what permissions they have, this includes which Areas and at what time/day that user has access.

### 12.3 Arm Your System in Stay Mode

Touch the Stay or Stay + button to arm your system in Stay mode:

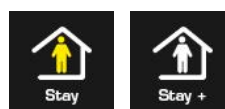

If your system has multi-Area control enabled, the Stay + button will be displayed. A valid PIN code will need to be entered to determine what permissions they have, this includes which Areas and at what time/day that user has access.

## 12.4 Disarm One or More Areas

Touch the Off or Off + button to arm your system in Away mode:



If your system has multi-Area control enabled, the Off + button will be displayed.

A valid PIN code will need to be entered to determine what permissions they have, this includes which Areas and at what time/day that user has access.

## 12.5 Activate SOS Feature

SOS functionality is enabled by default. See Areas Programming and the instructions in [Programming Areas](#). Touch the SOS button to display the SOS feature:

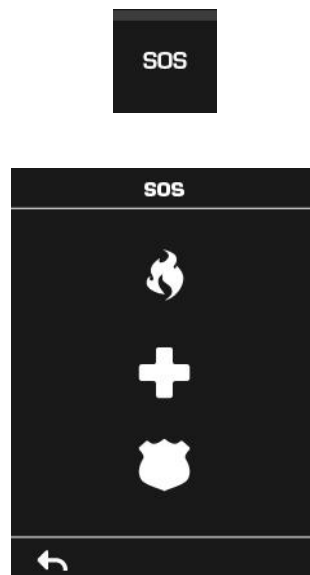

On this screen touch and hold the appropriate button for 2 seconds to activate Manual Fire Alarm, Manual Auxiliary Alarm, or Manual Panic Alarm.

Depending on how your system is programmed, the control room may receive the corresponding event. Check with your control room to determine what action will be taken. If silent alarm is enabled, then the keypad will not display any signs that the panic button was pressed.

To cancel a SOS alarm – return to the home screen, touch the Status button and turn the Area off.

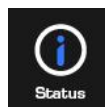



## 13 Glossary

<b>Action</b>	An action allows the system to perform automation functions. These can monitor the status up to 4 input conditions called Action Events, change state (Action State), and perform a function (Action Result) such as arming a range of areas.
<b>Action Group</b>	An action group is one or more actions that can be accessed by a device or user. They are assigned to a user or device via permissions.
<b>Area</b>	Sensors are grouped in to areas which can be secured independently from each other. This allows you to split your security system in to smaller components that can be separately managed. For example your system can be divided into an upstairs area and downstairs area.
<b>Area Group</b>	An area group is one or more areas that can be accessed by a device or user. They are assigned to a user or device via permissions.
<b>Arm</b>	To turn your security system <b>On</b> .
<b>Arm-Disarm</b>	Automatically arm and disarm areas by a specific user according to a specified schedule. The areas armed and disarmed will be the ones that the user has access to via their permissions.
<b>Away Mode</b>	To turn your security system on when you are leaving the premises.
<b>Bypass</b>	Sensors can be temporarily disabled so they will not be monitored by the security system. For example, an interior door is left open, bypass it to temporarily ignore it and allow arming of the security system. Bypassed sensors are not capable of activating an alarm. Sensors will return to normal operation when the system is armed then disarmed. This prevents unintentional permanent disabling of a sensor.
<b>Central Station</b>	A company to which alarm signals are sent during an alarm report. Also known as Central Monitoring Station (CMS).
<b>Channel</b>	A channel is a communication path for events to be sent from the system to a selected destination. Channels can be set to UltraSync or Email. A channel has an associated event list which contains the events it is allowed to forward on.
<b>Channel Group</b>	A channel group is one or more destinations for event messages to be sent to. When a message is sent to a channel group, it is sent to all the channels that it contains. It forms the basis of multi-path reporting in the system.
<b>Chime Group</b>	All the sensors that will activate chime, when in chime mode.

<b>Chime Mode</b>	An operational mode that will emit a ding-dong sound at the keypad when specific sensors are activated.
<b>Closed</b>	<p>A sensor in a normal state is “closed”. The security system monitors each sensor for changes in state from closed to open and can respond with certain actions such as sounding the siren.</p> <p>For example, a reed switch on a front door may change from a closed state to an open state when the door opens.</p>
<b>Communicator</b>	<p>The communicator is responsible for notifying a control room or third party that an alarm event has occurred so an appropriate response can be made.</p> <p>It sends event messages to the specified destination including details such as where the event originated from and the type of event. The receiver will then log the time and date when it receives the event. For example, Alarm from Sensor 2 in Area 1 at 3:00am on 5/5/2014 from Account 1234.</p> <p>The system has multiple communicator options including Ethernet IP interface, email, and 3G (with optional cellular radio module).</p>
<b>CPU</b>	The main controller for the security system. It stores all programming, provides network and other connectivity options for reporting, and provides physical terminals for connecting power, backup battery, sensors, and outputs.
<b>Disarm</b>	To turn your security system <b>Off</b> .
<b>Duress Code</b>	A predetermined user PIN code that will arm / disarm the security system while sending a special code to the central monitoring station indicating the user is entering / leaving the premises under duress. Only applicable on monitored systems.
<b>Entry Delay</b>	The time allowed to disarm your security system after the first detection device has been activated.
<b>Event</b>	Events are messages that are sent by the system due to system or area conditions. These include areas in alarm, opening and closing, sensor bypass, low battery, tamper, communication trouble, and power issues.
<b>Event List</b>	Event lists contain events that a channel is allowed to send to the specified destination. If a channel receives an event that is not in the associated event list, then the channel will ignore the event.
<b>Exit Delay</b>	The time allowed to exit the premises after the security system is armed.
<b>Forced Arming</b>	An option that permits arming even when there are open pre-selected sensors. Generally assigned to sensors that cover the system (e.g.; motion sensors, front door reed switches), allowing the user to arm the security system without the need to wait for those sensors to be closed. A security system that is ready to be “force armed” will flash the ready light.
<b>Handover</b>	An instant alarm type, unless an entry sensor is tripped first.
<b>Master Code</b>	A PIN code that is used by a user to arm or disarm the security system. Its main feature is the ability to create, alter and delete user PIN codes. Can also be used as a function code for all features.
<b>Menus</b>	<p>The system has a large range of features sorted into various menus such as Users, System, and Sensors. Each menu item can be seen when using the UltraSync Web Server or the UltraSync app.</p> <p>Menus are used to restrict what is displayed by a device and what features a user has access to.</p>
<b>Monitored</b>	A security system that is configured to send all alarm signals to a central monitoring station.

<b>Open</b>	<p>A sensor in an abnormal state is “open”. The security system monitors each sensor for changes in state from closed to open and can respond with certain actions such as sounding the siren.</p> <p>For example, when a PIR sensor detects movement it will change from a closed state to an open state</p>
<b>Output</b>	<p>Outputs on the system can be connected to a siren and strobe when an alarm condition occurs on the system.</p>
<b>Perimeter</b>	<p>Typically this refers to sensors located around the boundary of the protected area such as sensors on doors and windows, and excludes interior motion sensors.</p>
<b>Permission</b>	<p>Permission includes a list of features a user or device is allowed to access. This includes programming menus, areas, reporting channels, actions, reporting options, access control options, special options, and special timers.</p>
<b>Profile</b>	<p>Each user can have up to four (4) permission profiles. Each profile contains a set of permissions and a corresponding schedule. This allows advanced user programming and provides specific access to different features of the security system during specific dates/time.</p> <p>With advanced programming, profiles can be enabled/disabled in response to system conditions.</p>
<b>Quick Arm</b>	<p>An option that allows you to turn on (arm) the security system by pressing the [AWAY] key.</p>
<b>Scene</b>	<p>Each scene can trigger up to 16 actions to create an automation event. This can save users time by automatically running multiple actions. A scene can be triggered manually, through a schedule, or via a system event.</p>
<b>Schedule</b>	<p>A schedule is a list of up to 16 sets of days and times. Typically these are used to provide access to users only within the specified sets of days and times. Outside of the schedule a user will not have access to the system.</p> <p>Schedules are used to automatically arm and disarm specified areas using the Arm-Disarm feature.</p> <p>Scenes can perform a set of actions according to a specified schedule.</p> <p>Schedules themselves can be enabled and disabled through actions. This powerful feature allows you to provide conditional access to various users and devices based on system conditions.</p>
<b>Sensor</b>	<p>A detection device such as a Passive Infrared motion sensor (PIR), reed switch, smoke detector, panic button, etc. Sensors may be physically wired to the system.</p> <p>Also known as an input or sensor on other security panels.</p>
<b>Service Provider</b>	<p>The installation / maintenance company servicing your security system.</p>
<b>Stay Mode</b>	<p>To turn your security system on when you are staying in the premises, this will automatically bypass pre-programmed sensors and arm others. Often used to arm only the perimeter while allowing movement inside the premises.</p>

<b>Tamper</b>	<p>A physical switch on a device that detects unauthorised access to the unit. For example opening the case of a sensor or taking a keypad off the wall can trigger a tamper alarm. This can provide early warning of someone attempting to undermine the security of your system.</p> <p>Some devices use an optical sensor to detect removal from a surface.</p>
<b>Token</b>	<p>Each token is a pre-recorded word or phrase that can be used to name sensors, areas, outputs, and rooms.</p>
<b>UltraSync</b>	<p>Mobile app for smartphones to access the UltraSync Web Server which provides access to view the status of a system, control sensors and outputs, program users and other features. Available to download for Apple™ iPhone™ and Google™ Android™ from the respective app store.</p> <p>The UltraSync app connects to the UltraSync server which will then connect to your system.</p>
<b>UltraSync Web Server</b>	<p>The system has a built-in web server which provides access to features via a web browser interface or a native smartphone app.</p> <p>This allows you to performing programming and control of the system without needing to be physically in front of the keypad.</p>
<b>User</b>	<p>An authorised person who can interact with the system security system and perform various tasks according to the permissions assigned to them.</p> <p>Each user has a set of profile levels. These control what the user has access to, a list of functions, and when the user is allowed to perform these functions.</p> <p>A user is typically a person who is assigned a PIN code and arms/disarms the system with this code or keyfob device.</p> <p>Users can also be automatic functions of the system. For example, the system can automatically arm specific areas a user has access to at a specified time. No human interaction is required; all the permissions of the programmed user will still be applied and enforced.</p>
<b>User Code</b>	<p>A PIN code that is used by a user to arm or disarm the security system. Also can be used as a function code for certain features.</p>

## Appendices

### A.1 DLX 900 Software

DLX 900 is a fully featured management tool for control rooms and security professionals. Compatible with Microsoft Windows 7 and 8, this is available to download from [www.interlogix.com](http://www.interlogix.com).

In order for DLX 900 to connect to an UltraSync system you will need:

- The IP address of the system (or use the Discover feature for LAN connections)
- To know the Download Access Code (see Troubleshooting section, A.2) and,
- If Always Allow DLX 900 is enabled then you will be allowed to connect; if Always Allow DLX 900 is disabled then you must first put the UltraSync into program mode, this can be changed in Settings-Network.

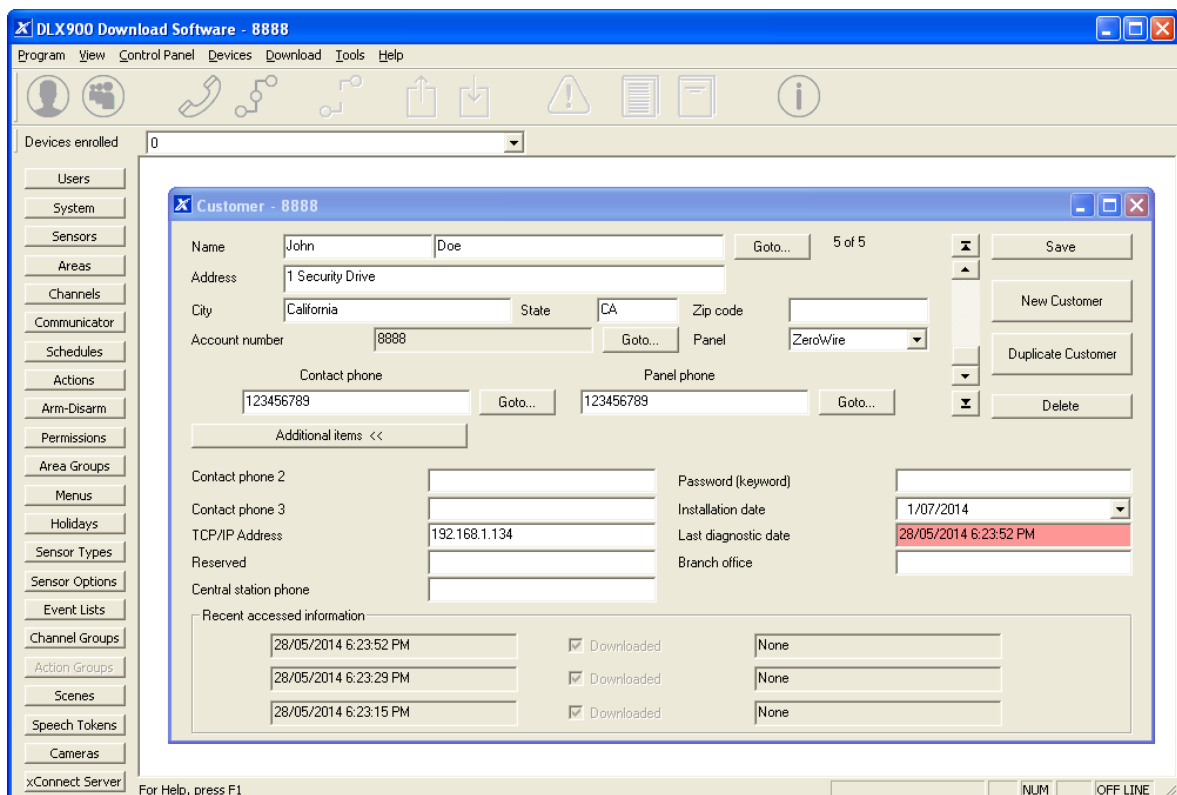

1. Install and launch DLX 900 software.
2. Create a new customer and select the Panel.

3. Enter the **TCP/IP address** of the system, press **Save**.
4. Go to Communicator – Remote Access.

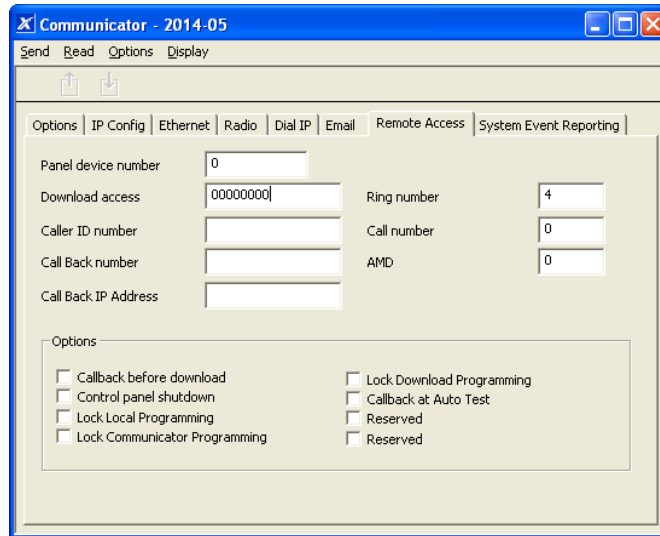

5. Enter the **Download Access Code** to match the one configured on the system.
6. Press the **Connect TCP/IP** button.

To enable remote access for DLX 900 in UltraSync, change the Download Access Code. The default Download Access Passcode of 00000000 prevents remote access. Login to UltraSync Web Server and go to Settings – Network then change the code.

**Note:** DLX 900 will attempt to connect using the default **installer / 9-7-1-3** account. To disable DLX 900 access, change the Installer PIN code and set the Download Access Code to 00000000.

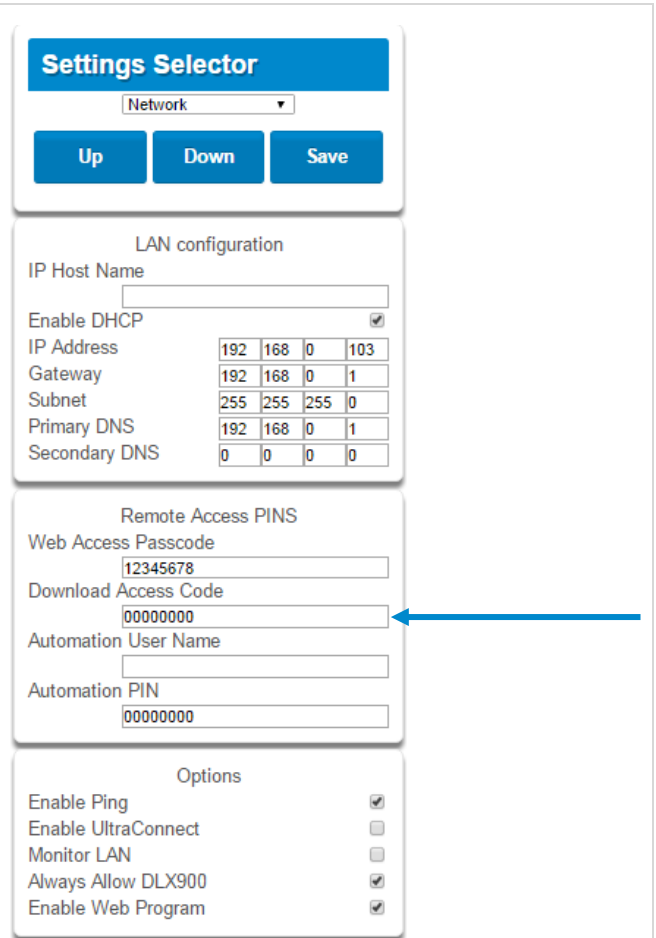

## A.2 Troubleshooting DLX 900

Problem	Solution
<p>Cannot connect over TCP/IP</p>	<p>Check you can ping the system.</p> <p>Check the Download Access Code.</p> <p>Check that remote access is enabled on the system.</p> <p>You generally need to be on the same network to connect via TCP/IP. If you are connecting from a separate network, you will need to set up port forwarding to port 41796 on the router the system is connected to. Consult your router manual or your IT department for assistance. Technical support is unable to assist with setting up port forwarding due to differences in customer networks and equipment.</p>
<p>Do not know Download Access Code</p>	<p>Login to UltraSync Web Server and go to Settings – Network. Generally this will need to be done on-site with an internet browser.</p> <p>At factory default, DLX 900 will automatically allow a connection using the default Go To Program Code / Installer Code of <b>9-7-1-3</b> even if the Download Access Code is unknown or set to default of 00000000 (disable upload/download). This is a convenience feature for Installers and control rooms when a system is first installed.</p> <p>This is why you must change the Installer Code to protect the system from further changes. Once the Installer Code has been changed, this feature no longer works and you must have the correct Download Access Code.</p>

## A.3 Firmware Upgrade using DLX 900

Upgrading firmware can be performed remotely using DLX 900.

1. Check with your supplier to download the latest firmware file for your device.
2. Open DLX 900 and go to **Devices – Device Info**:

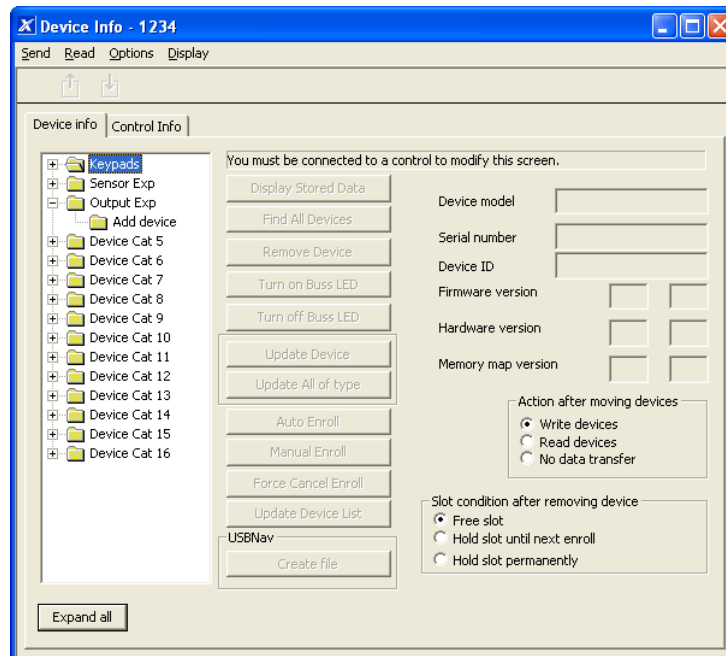

3. Select the device you want to upgrade. If you wish to update the system, select the **Control Info** tab.
4. Press **Update Device**, **Update All of Type**, or **Update Control**.
5. Select the firmware file.
6. Press **OK**.
7. Wait for the firmware files to transfer to your device(s).



## A.4 Voice Library

These words can be used to customize your sensor names.

0	zero	39	boat	78	gym	117	roof
1	one	40	cabinet	79	hall	118	room
2	two	41	car park	80	hallway	119	rumpus
3	three	42	ceiling	81	heat	120	safe
4	four	43	cellar	82	heating	121	security
5	five	44	child's	83	hold-up	122	sensor
6	six	45	alert	84	home	123	shed
7	seven	46	closet	85	home theatre	124	shock
8	eight	47	computer	86	infra-red	125	shop
9	nine	48	cool	87	inside	126	side
10	ten	49	curtain	88	instant	127	skylight
11	eleven	50	data	89	interior	128	sliding
12	twelve	51	den	90	key switch	129	small
13	thirteen	52	detector	91	Keychain	130	smoke
14	fourteen	53	dining	92	kitchen	131	south
15	fifteen	54	door	93	lounge	132	stairs
16	sixteen	55	downstairs	94	laundry	133	storage
17	seventeen	56	driveway	95	lift	134	study
18	eighteen	57	duress	96	light	135	temperature
19	nineteen	58	east	97	living	136	spare
20	twenty	59	emergency	98	location	137	toilet
21	thirty	60	entry	99	master	138	training
22	forty	61	family	100	medicine	139	T V
23	fifty	62	fan	101	meeting	140	upstairs
24	sixty	63	fence	102	motion	141	user
25	seventy	64	fire	103	night	142	utility
26	eighty	65	forced arm	104	north	143	volt
27	ninety	66	foyer	105	nursery	144	veranda
28	hundred	67	freezer	106	office	145	wall
29	thousand	68	front	107	output	146	warehouse
30	air conditioner	69	games	108	outside	147	water
31	area	70	garage	109	panic	148	west
32	attic	71	gas	110	pantry	149	window
33	automatic	72	gate	111	partial	150	windows
34	auxiliary	73	glass	112	perimeter	151	wireless
35	back	74	glass break	113	pool	152	yard
36	basement	75	ground	114	rear		
37	bathroom	76	guest	115	reception		
38	bedroom	77	gun	116	remote		

## A.5 System Status Messages

Various messages may appear on the Status screen of UltraSync Web Server and UltraSync app.

### System

- AC power fail – The security system has lost its electricity power.
- Low battery – The security system's back up battery requires charging.
- Battery test fail – The security system's back up battery requires changing.
- Box tamper – The security system's cabinet tamper input has activated.
- Siren trouble – The security system's external siren has a problem.
- Over current – The security system is drawing too much current.
- Time and date loss – The security system time and date need resetting.
- Communication fault – The security system has detected a problem with the communication channel
- Fire alarm – A fire alarm has been activated from the system
- Panic – A manual alarm has been activated from the system
- Auxiliary – A manual auxiliary alarm has been activated from the system

### Area Number / Area Name

- Is On in the away mode – This area is armed in the away mode.
- Is On in the stay mode – This area is armed in the stay mode.
- Is ready – This area is secure and ready to be armed.
- Is not ready – This area is NOT ready to be armed, a sensor is not secure.
- All areas are on in the away mode – All areas in this multi area system are armed in the away mode.
- All areas are on in the stay mode – All areas in this multi area system are armed in the stay mode.
- All areas are ready – All areas in this multi area system are secure and ready to be armed.

### Sensor Number / Sensor Name

- In Alarm – This sensor has triggered a system alarm condition.
- Is bypassed – This sensor is isolated (disabled) and will not activate an alarm.
- Chime is set – This sensor is part of the chime group.
- Is not secure – This sensor is not closed.
- Fire alarm – This sensor has triggered a fire alarm.
- Tamper – This sensor has triggered a tamper alarm.
- Trouble fault – This sensor has an open circuit.
- Loss of wireless supervision – This sensor is a wireless device and has lost its communication link with the control panel.
- Low battery – This sensor is a wireless device and needs its battery changed.

## A.6 App and Web Error Messages

Various error messages may appear on the UltraSync Web Server and UltraSync app.

### Advanced / Settings Configuration Menus

- "You must select a Menu before you can scroll" – An attempt was made to scroll up or down from the top level menu.
- "Select a submenu from the list or select back to access the main menu" – An attempt was made to scroll up or down from a submenu that has no additional levels.
- "Defaulting requires 2 levels" – a Shortcut was entered without two levels.

### Read Write errors and results

- "Write Access Denied"
- "Nothing displayed can be Saved"
- "Program Success!"
- "Name Saved"

### Sensors Page

- "No Sensors Configured For Your Access" – Displayed on Sensors page when there are no sensors available to view.

### Data Entry Errors

- "Data must only contain the following characters"
- "Date must be of the form YYYY-MM-DD."
- "Day must be from 1 to 31"
- "Data entry must only contain the numbers 0 – 9 and A–F"
- "Data entry must only contain the numbers 0 – 9"
- "Data must be a number from X to Y"
- "Improper Time Value"
- "must be 4 to 8 digits"
- "You must enter a user Number between 1 and 1048575"
- "PIN digits must be between 0 and 9"
- "PIN Must be 4–8 digits from 0–9"
- "Data must not contain the following characters []"

## A.7 Z-Wave Messages

### Z-Wave Messages

- "Unavailable – Failed Device Function in progress" – An Attempt was made to enter an add remove mode when failed device mode is active.
- "Unavailable – Add mode active" – Attempt was made to enter an add remove mode when add mode is active.
- "Unavailable – Remove mode active" – An Attempt was made to enter an add remove mode when remove mode is active.
- "Unavailable – Resetting Network" – An Attempt was made to enter an add remove mode when resetting mode is active.
- "Unavailable – Backing Up Network" – An Attempt was made to enter an add remove mode when backup mode is active.
- "Unavailable – Restoring Network" – An Attempt was made to enter an add remove mode when restore mode is active.
- "Busy, Try Again Momentarily" – This message is received when the Z-Wave module is attempting a command and a new command was submitted.
- "Not primary controller" – An attempt was made to perform device functions when not a primary controller.
- "Device Not Found in failed list" – An attempt was made to remove a failed device that is now responding.
- "Remove Device failed – already in process" – An Attempt was made to enter remove mode when remove mode is active.
- "Replace Device failed – already in process" – An Attempt was made to enter Replace mode when Replace mode is active.
- "Remove Failed" – An Attempt to remove a device from the network has failed
- "Replace Failed" – An Attempt to replace a device from the network has failed
- "Function timed out or canceled" Add/Remove/Replace function timed out.
- "Unavailable, Try Again Later" – This message is received when the Z-Wave module is still initializing
- "Command Failed" – A Z-Wave command has failed.
- "You must press **Select** to choose a set point" – A set point change was attempted without selecting a set point to change.
- "There are no Failed Devices" – Displayed in the failed device dialog when no failed devices detected.

## A.8 History Events

The table below lists events that can appear in the event log.

**Event ID Table**

Event Name	Description
24 Hour Alarm	
24 Hour Alarm Restore	
Abort	
Activity Monitor fail	
Alarm Aborted	Alarm was aborted
Automatic Test	
Battery Low Event	
Battery Low Event Restore	
Box Tamper	
Box Tamper Restore	
Burg Alarm	
Burg Alarm Restore	
Bypass	
Bypass Restore	
Cancel	
Checksum Fault	
Checksum Fault Restore	
Clock Changed	
Close	
Communication Failure	
Communication Failure Restore	
Cross Zone initial trip	
Cross Zone initial trip Restore	
Device Enrolled	
Device Failure	
Device Failure Restore	
Door Access	
Door Access Denied	
Door Forced	
Door Forced	
Door Propped	
Door Propped	
Duress	
Early Opening	
Early Opening	
End Listen In	
End Local Program	
End Remote Program	
End Walk Test Mode	
End Sensor Test	
Exit Error	
Expander DC Loss	
Expander DC Loss Restore	
Expander Low Battery	
Expander Low Battery Restore	
Fail To Close	
Fail to Open	
Fire Alarm	
Fire Alarm Restore	
Fire Maintenance Alarm	
Fire Maintenance Alarm Restore	

Fire Supervision	
Fire Supervision Restore	
First Open	
Ground Fault	
Ground Fault Restore	
Guard Tour Fail	
Keypad Lockout	
Last Close	
Late Closing	
Late Opening	
Mains Fail Event	
Mains Fail Event Restore	
Man Down	
Manual Audible Panic	
Manual Fire	
Manual Auxiliary	
Manual Silent Panic	
Manual Test	
Manual Test Restore	
Open	
Output Activated	
Output Deactivated	
Over Current	
Over Current Restore	
Partial Close	
Partial Open	Opening from Partial Arm
Power Up	
Power Up Restore	
Recent Close	
Remote Program Fail	
Reserved	
Reserved Sensor Event Types/Restores	
Sensor Low Battery	
Sensor Low Battery Restore	
Serial Bus Expansion Event	
Siren Tamper	
Siren Tamper Restore	
Start Listen In	
Start Local Program	
Start Remote Program	
Start Walk Test Mode	
Start Sensor Test	
System Device Bypassed	
System Device Un-bypassed	
System Shut Down	
System Armed	Restore from system shutdown
Tamper	
Tamper Restore	
Technician Arrival	
Technician Left	
Telephone Fault	
Telephone Fault Restore	
Trouble	
Trouble Restore	
User Activated Output	
Valid Code Entered	
Valid Code expired	
Valid Code lost	
Valid Code out of Schedule	
Valid Code Void	

Walk Test Fail	
Walk Test Pass	
Watchdog Reset	
Wireless Jam	
Wireless Jam Restore	
Wireless Supervision	
Wireless Supervision Restore	
Sensor Activity Supervision	
Sensor Activity Supervision Restore	

## A.9 Event Reporting Class Table

Class Name	Description
Bypass/Bypass Restore	Sensor has been isolated
Cancel	
Communication Failures	
Don't care	Used for devices that do not classify events.
Fire Alarm	A fire device created an alarm
Fire Restore	A fire device restored from Alarm
Log Only	
Non-Fire Alarm	A non-fire device created an alarm. This includes auxiliary, panic, and burg.
Non-Fire Restore	A non-fire device restored from alarm.
Open/Close	An area turn on turn off
Power Trouble	Mains and battery trouble
Program Mode	Local or remote programming
Recent Close/Abort	
Reserved	
Sensor Trouble/restore	Low battery or wireless supervision
System trouble/Restore	A system trouble event or restore.
Tampers/Tamper Restore	A tamper alarm or tamper restore.
Test Reports	Manual or automatic test event
Sensor Trouble/Restore	A fire sensor or day sensor is in trouble or restored from trouble.

## A.10 Action Events: Category and Types

Action Events Category	Action Event Type	Action Events Category	Action Event Type
Sensor Events	<ul style="list-style-type: none"> <li>Disabled</li> <li>Faulted</li> <li>Not Faulted</li> <li>Alarm</li> <li>Bypass</li> <li>Tamper</li> <li>Low Battery</li> <li>Trouble</li> <li>Supervision</li> <li>Chime Enabled</li> <li>Inhibited (Bypassed)</li> <li>Alarm Memory</li> </ul>	User Events	<ul style="list-style-type: none"> <li>Disabled</li> <li>PIN entered</li> <li>PIN Entered out of schedule</li> <li>Void PIN Entered</li> <li>Lost PIN Entered</li> <li>Expired PIN Entered</li> <li>Turn On By User</li> <li>Turn Off By User</li> </ul>
Area Events	<ul style="list-style-type: none"> <li>Disabled</li> <li>Armed Away</li> <li>Armed Away + Bypass</li> <li>Armed Partial</li> <li>Auto Arm Warning</li> <li>Holdup Delay</li> <li>Timed Disarm</li> <li>Guard Tour Time</li> <li>Guard Tour Fail</li> <li>Man Down Timer</li> <li>Man Down Fail</li> <li>Entry</li> <li>Exit 1 or Exit 2</li> <li>Exit 1</li> <li>Exit 2</li> <li>Silent Exit Active</li> <li>Exit Error</li> <li>Abort Window</li> <li>Cancel Window</li> <li>Sensor Cross Zone Timing</li> <li>Sensor Bypass</li> <li>Sensor Tamper</li> <li>Sensor Not Ready</li> <li>Sensor Low Battery</li> <li>Sensor Supervision Fault</li> <li>Chime On (from sensor)</li> <li>Walk Test (from sensor)</li> <li>Trouble (from sensor)</li> <li>Any Alarm</li> <li>Burg Alarm</li> <li>Fire Alarm</li> <li>Panic Alarm</li> <li>Auxiliary Alarm</li> <li>Any Siren</li> <li>Fire Siren</li> <li>Non-fire Siren</li> <li>Keypad Sounder</li> <li>DLX 900 Turn off command</li> <li>DLX 900 Turn on partial</li> <li>DLX 900 Turn on away</li> <li>Manual Fire</li> <li>Manual Panic</li> <li>Manual Auxiliary</li> <li>User Arm Trigger</li> <li>User Disarm Trigger</li> </ul>	Logic State	<ul style="list-style-type: none"> <li>Disabled</li> <li>Action State True</li> <li>Manual Output On</li> <li>Manual Output Off</li> <li>Scene Activated</li> <li>Action State False</li> </ul>
		Schedule States	<ul style="list-style-type: none"> <li>Disabled</li> <li>Schedule State</li> </ul>
		Device Status	<ul style="list-style-type: none"> <li>Disabled</li> <li>Fire Alarm Verification</li> <li>Box Tamper</li> <li>Local Programming</li> <li>Remote Programming</li> <li>Battery Test</li> <li>Off line</li> <li>Power Up delay</li> <li>Shut Down</li> <li>Phone Communicator trouble</li> <li>Phone Line fault</li> <li>Ethernet Trouble</li> <li>Ethernet No Link</li> <li>Ethernet to Server Fault</li> <li>Cellular Radio Trouble</li> <li>Cellular Radio to Server Fault</li> <li>Event in Reporting Queue</li> <li>Smoke Power Fail</li> <li>Mains Fail</li> <li>Low System Battery</li> <li>Strobe On</li> <li>Siren On</li> <li>Siren Tamper</li> </ul>
		System Events	<ul style="list-style-type: none"> <li>Disabled</li> <li>Remote Program Fail</li> <li>Watchdog Reset</li> </ul>
		Room Events	<ul style="list-style-type: none"> <li>Disabled</li> <li>Connected To</li> <li>Pending Connection To</li> <li>Privacy</li> <li>Talking</li> <li>Using Channel 1</li> <li>Using Channel 2</li> </ul>



## A.11 Action Results Category and Action Results Event Types

Action Results Category	Action Results Event Type	Action Results Category	Action Results Event Type
Sensor Results	Sensor Trip Toggle Sensor Trip Sensor Restore Sensor Bypass Toggle Sensor Bypass Sensor Unbypass Sensor Chime Toggle Sensor Chime On Sensor Chime Off	User Results	User Expire or Activate User Activate User Deactivate
Area Results	Arm Away Turn Off Silence Arm Stay Toggle Arm Stay Arm Away No Auto Stay Chime Toggle Chime On Chime Off Automatic Sensor Test Toggle Automatic Sensor Test On Automatic Sensor Test Off Auto Arm Timer Restart Disarm Timer Restart Man Down Timer Restart Guard Tour Timer Restart Hold Up Timer Restart Activity Timer Restart Arm or Disarm Test Timer Restart	System Results	Disabled Detector Reset Communicator Test
		Device Results	Disabled Battery Test Start Siren Device Bypass Device Unbypass
		Camera Results	Camera 1 Camera 2 Camera 3 Camera 4 Camera 5 Camera 6 Camera 7 Camera 8 Camera 9 Camera 10 Camera 11 Camera 12 Camera 13 Camera 14 Camera 15 Camera 16
Scene Results	Scene 1 Scene 2 Scene 3 Scene 4 Scene 5 Scene 6 Scene 7 Scene 8 Scene 9 Scene 10 Scene 11 Scene 12 Scene 13 Scene 14 Scene 15 Scene 16		

## A.12 System Building Blocks

On the following page is the system diagram of system showing all the different building blocks that can be used to create an UltraSync system.

You have full flexibility to customise your system. Program each building block in turn to complete your system. We suggest left to right, top to bottom. Refine blocks as you go or use pre-sets to save you time.

The smaller grey blocks indicate related blocks that are used by the larger blue block.

The number on the bottom right of each block indicates the capacity of the system.

**System**  
 a) System Clock  
 b) System and Siren  
 c) Timers  
 d) Maintenance and Test

**Sensor Types**  
 - Area Armed  
 - Area Disarmed

**Sensor Options**

**Zones**  
 a) Profile 1  
 b) Profile 2

Sensor Type  
 Sensor Options  
 Area Group  
 Schedule  
 User

up to 512\*

**Areas**  
 a) Area Options  
 b) Area Timers  
 c) Area Reporting

Schedule  
 Channel Groups

up to 96\*

**Area Groups**

Areas

128

**Communicator**  
 a) General Options  
 c) IP Config  
 d) Ethernet  
 d) Radio  
 d) Dial IP  
 d) Email  
 e) Remote Access  
 f) System Event Reporting

Channel Groups

**Event Lists**

16

**Channels**

Communicator  
 Event Lists

16

**Channel Groups**

Channels

16

**Menus**  
 a) Setup  
 b) Security...  
 c) History...  
 d) Communications  
 e) Times...

64

**Holidays**

4

**Schedules**

Holidays

96

**Permissions**  
 a) Groups  
 b) Options/Timers

Menus  
 Area Groups  
 Channel Groups  
 Action Groups

128

**User**  
 a) Main  
 b) Advanced

Permissions  
 Schedules

up to 256\*

**Arm/Disarm**

User  
 Schedule

96

**Actions**

up to 256\*

**Action Groups**

Actions

64

**Scenes**

Actions  
 Schedules

16

**Devices Outputs**  
 zone expanders, keypads,  
 transmitters

Permissions  
 Schedules

64

**Speech Tokens**

**Network Servers**

## A.13 System Menu Tree

The menu structure as seen from the Advanced menu in UltraSync Web Server:

<p><b>910.1 Users</b></p> <p><b>910.2 System</b></p> <ol style="list-style-type: none"> <li>1. System Clock</li> <li>2. General Options</li> <li>3. System Timers</li> <li>4. Siren Options</li> <li>5. Service and Test Options</li> <li>6. Status</li> <li>7. System Counters</li> <li>8. Language               <ol style="list-style-type: none"> <li>1. Language</li> <li>2. Voice language</li> </ol> </li> <li>9. Automation Menu</li> </ol> <p><b>910.3 Sensors</b></p> <ol style="list-style-type: none"> <li>1. Sensor Number</li> <li>2. Sensor Name</li> <li>3. First Sensor Profile</li> <li>4. Second Sensor Profile</li> </ol> <p><b>910.4 Areas</b></p> <ol style="list-style-type: none"> <li>1. Area Number</li> <li>2. Area Name</li> <li>3. Area Entry-Exit Times</li> <li>4. Area Options</li> <li>5. Area Timers</li> <li>6. Area Type Settings</li> <li>7. Area Event Reporting</li> </ol> <p><b>910.5 Reporting and Notifications</b></p> <ol style="list-style-type: none"> <li>1. Channel Number</li> <li>2. Channel Name</li> <li>3. Account Number</li> <li>4. Format</li> <li>5. Device Number</li> <li>6. Dest Phone or Email or Push</li> <li>7. Next Channel</li> <li>8. Event List</li> <li>9. Attempts</li> <li>10. Language</li> </ol> <p><b>910.6 Communicator</b></p> <ol style="list-style-type: none"> <li>1. General Options</li> <li>2. Auto Test</li> <li>3. IP Configuration           <ol style="list-style-type: none"> <li>1. IP Host Name</li> <li>2. IP Address</li> <li>3. Gateway</li> <li>4. Subnet</li> <li>5. Primary DNS</li> <li>6. Secondary DNS</li> <li>7. Ports</li> <li>8. Time Server</li> <li>9. IP Options</li> </ol> </li> <li>4. Cellular Configuration</li> <li>5. Remote Access           <ol style="list-style-type: none"> <li>1. Panel Device Number</li> <li>2. Download Access Code</li> <li>3. Call Back Number</li> <li>4. Callback Server</li> <li>5. Number Of Rings</li> <li>6. Number of Calls</li> <li>7. Answering Machine Defeat</li> <li>8. Download Options</li> </ol> </li> <li>6. System Event Reporting           <ol style="list-style-type: none"> <li>1. System Channel</li> <li>2. Attempts</li> </ol> </li> </ol>	<p><b>910.7 Schedules</b></p> <ol style="list-style-type: none"> <li>1. Schedule Number</li> <li>2. Schedule Name</li> <li>3. Follow Action Number</li> <li>4. Times and Days</li> </ol> <p><b>910.8 Actions</b></p> <ol style="list-style-type: none"> <li>1. Action Number</li> <li>2. Action Name</li> <li>3. Function</li> <li>4. Duration Minutes</li> <li>5. Duration Seconds</li> <li>6. Event 1</li> <li>7. Event 2</li> <li>8. Event 3</li> <li>9. Event 4</li> <li>10. Result</li> </ol> <p><b>910.9 Auto Arm-Disarm</b></p> <ol style="list-style-type: none"> <li>1. Arm-Disarm Number</li> <li>2. Name</li> <li>3. User Number</li> <li>4. Schedule Number</li> </ol> <p><b>910.10 Devices</b></p> <ol style="list-style-type: none"> <li>1. System Devices           <ol style="list-style-type: none"> <li>1. Control</li> <li>2. Keypad</li> <li>3. Zone Expanders</li> <li>4. Relay Expanders</li> <li>5. Power Supplies</li> </ol> </li> <li>2. Interlogix Transmitters           <ol style="list-style-type: none"> <li>1. Transmitter Number</li> <li>2. Serial Number</li> <li>3. User</li> <li>4. Options</li> <li>5. Scene</li> <li>6. Signal Strength</li> </ol> </li> <li>3. Z-Wave Devices           <ol style="list-style-type: none"> <li>1. Name</li> <li>2. Basic Type</li> <li>3. Generic Type</li> <li>4. Specific Type</li> </ol> </li> </ol> <p><b>910.11 Permissions</b></p> <ol style="list-style-type: none"> <li>1. Permission Number</li> <li>2. Permission Name</li> <li>3. Control Groups</li> <li>4. Permission Options</li> <li>5. User Timer Options</li> </ol> <p><b>910.12 Area Groups</b></p> <ol style="list-style-type: none"> <li>1. Area Group Number</li> <li>2. Area Group Name</li> <li>3. Area List</li> </ol> <p><b>910.13 Menus</b></p> <ol style="list-style-type: none"> <li>1. Menu Number</li> <li>2. Menu Name</li> <li>3. Menu Selections</li> </ol> <p><b>910.14 Holidays</b></p> <ol style="list-style-type: none"> <li>1. Holiday Number</li> <li>2. Holiday Name</li> <li>3. Date Range</li> </ol>	<p><b>910.15 Sensor Types</b></p> <ol style="list-style-type: none"> <li>1. Sensor Type Number</li> <li>2. Sensor Type Name</li> <li>3. Sensor Type Armed</li> <li>4. Sensor Type Disarmed</li> </ol> <p><b>910.16 Sensor Options</b></p> <ol style="list-style-type: none"> <li>1. Sensor Options Number</li> <li>2. Sensor Options Name</li> <li>3. Sensor Options</li> <li>4. Sensor Reporting</li> <li>5. Sensor Contact Options</li> <li>6. Sensor Report Event</li> </ol> <p><b>910.17 Event Lists</b></p> <ol style="list-style-type: none"> <li>1. Event List Number</li> <li>2. Event List Name</li> <li>3. Event List</li> </ol> <p><b>910.18 Channel Groups</b></p> <ol style="list-style-type: none"> <li>1. Channel Group Number</li> <li>2. Channel Group Name</li> <li>3. Channel</li> </ol> <p><b>910.19 Action Groups</b></p> <ol style="list-style-type: none"> <li>1. Action Group Number</li> <li>2. Action Group Name</li> <li>3. Action Group List</li> </ol> <p><b>910.20 Scenes</b></p> <ol style="list-style-type: none"> <li>1. Scene Number</li> <li>2. Scene Name</li> <li>3. When Should Scene Work</li> <li>4. Scene Trigger Type</li> <li>5. Activate Sensor</li> <li>6. Scene Results</li> </ol> <p><b>910.21 Speech Tokens</b></p> <ol style="list-style-type: none"> <li>1. Sensor Number</li> <li>2. Voice Name 1</li> <li>3. Voice Name 2</li> <li>4. Voice Name 3</li> <li>5. Voice Name 4</li> <li>6. Voice Name 5</li> <li>7. Voice Name 6</li> <li>8. Voice Name 7</li> <li>9. Voice Name 8</li> </ol> <p><b>910.22 Cameras</b></p> <ol style="list-style-type: none"> <li>1. Camera Number</li> <li>2. Camera Name</li> <li>3. LAN IP Address</li> <li>4. MAC Address</li> </ol> <p><b>910.23 Network Servers</b></p> <ol style="list-style-type: none"> <li>1. Web Access Passcode</li> <li>2. Ethernet Server 1</li> <li>3. Ethernet Server 2</li> <li>4. Ethernet Server 3</li> <li>5. Ethernet Server 4</li> <li>6. Cellular Server 1</li> <li>7. Cellular Server 2</li> <li>8. Cellular Server 3</li> <li>9. Cellular Server 4</li> </ol>
--------------------------------------------------------------------------------------------------------------------------------------------------------------------------------------------------------------------------------------------------------------------------------------------------------------------------------------------------------------------------------------------------------------------------------------------------------------------------------------------------------------------------------------------------------------------------------------------------------------------------------------------------------------------------------------------------------------------------------------------------------------------------------------------------------------------------------------------------------------------------------------------------------------------------------------------------------------------------------------------------------------------------------------------------------------------------------------------------------------------------------------------------------------------------------------------------------------------------------------------------------------------------------------------------------------------------------------------------------------------------------------------------------------------------------------------------------------------------------------------------------------------------------------------------------------------------------------------------------------------------------------------------------------------------------------------------------------------------------------------------------------------------------------------------------------------------------------------------------------------------------------------------------------------------------------------------------------------------------------------------------------------------------------------------------------------------------------------------------------------------------------------------------------------------------------------------------------	-----------------------------------------------------------------------------------------------------------------------------------------------------------------------------------------------------------------------------------------------------------------------------------------------------------------------------------------------------------------------------------------------------------------------------------------------------------------------------------------------------------------------------------------------------------------------------------------------------------------------------------------------------------------------------------------------------------------------------------------------------------------------------------------------------------------------------------------------------------------------------------------------------------------------------------------------------------------------------------------------------------------------------------------------------------------------------------------------------------------------------------------------------------------------------------------------------------------------------------------------------------------------------------------------------------------------------------------------------------------------------------------------------------------------------------------------------------------------------------------------------------------------------------------------------------------------------------------------------------------------------------------------------------------------------------------------------------------------------------------------------------------------------------------------------------------------------------------------------------------------------------------------------------------------------------------------------------------------------------------------------------------------------------------------------------------------	-----------------------------------------------------------------------------------------------------------------------------------------------------------------------------------------------------------------------------------------------------------------------------------------------------------------------------------------------------------------------------------------------------------------------------------------------------------------------------------------------------------------------------------------------------------------------------------------------------------------------------------------------------------------------------------------------------------------------------------------------------------------------------------------------------------------------------------------------------------------------------------------------------------------------------------------------------------------------------------------------------------------------------------------------------------------------------------------------------------------------------------------------------------------------------------------------------------------------------------------------------------------------------------------------------------------------------------------------------------------------------------------------------------------------------------------------------------------------------------------------------------------------------------------------------------------------------------------------------------------------------------------------------------------------------------------------------------------------------------------------------------------------------------------------------------------------------------------------------------------------------------------------------------------------------------------------------------------------------------------------------------------------------------------------------------------------------------------

## A.14 Calculating Maximum Bus Cable Length

When long RS-485 bus cable runs and/or many devices are connected on a single cable segment, voltage losses on the bus wiring may cause the bus voltage to drop below the required level to power the connected devices.

Factors contributing to voltage drop:

1. The more devices that are connected on the cable segment, the higher the current and hence, the higher the voltage drop
2. The longer the cable run, the higher the voltage drop
3. A lower gauge wire will have more voltage drop than a higher gauge wire

If these factors drop the bus voltage below the minimum voltage required to power the connected devices (device shutdown voltage), a UM-SPS Smart Power Supply must be inserted in the cable segment such that the bus voltage remains above the device shutdown voltage.

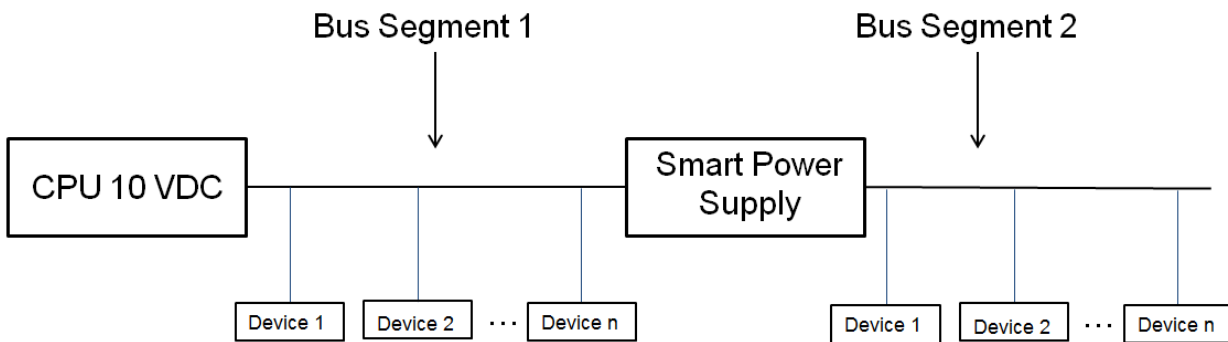

When designing the power system, you must design it for the worst case scenario. That is, 1) when AC power is lost and the system is operating off of battery power and 2) for the alarm or maximum current of the connected devices.

When AC power is lost and the system is operating off of battery power, the system will shut down when the CPU output voltage drops below 10 VDC. Thus, the voltage drop from 10 VDC must be used to determine the bus voltage given the total current on that section of bus wiring AND the gauge of the wiring used.

1. Add up the maximum current on the bus segment
2. Determine the highest shut down voltage for all devices on the bus segment
3. Use the appropriate chart below for the AWG of the cable for this segment to determine the maximum cable length
4. If the actual bus segment length exceeds the maximum cable length in the chart, you will need to break up the segment with a UM-SPS Smart Power Supply.

Example calculation of total bus segment current:

- 1) Add up maximum current value for all connected devices
- 2) Determine highest shut down voltage for all devices on bus segment

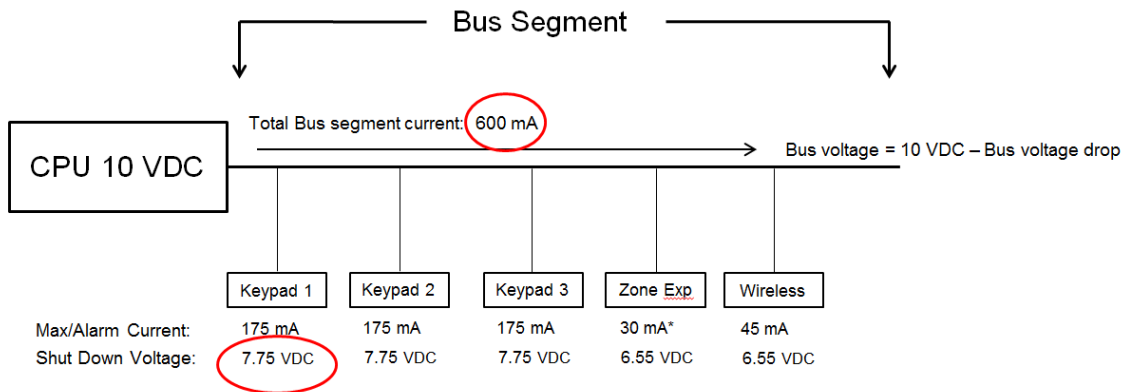

\* Current assumes Zone Expansion Module current only. If powered sensors are attached, sensor current must be added to value

Maximum bus segment length = 100' before Smart Power Supply is required

- Total Bus segment current: 600mA
- Worst Case device shut-down voltage: 7.75 VDC (keypad)
- 22 AWG wire

**Bus Voltage, 22 AWG Bus Wire**

Bus Current mA	Bus Length in Feet								
	50	100	200	500	750	1000	1500	2000	2500
25	10.0	9.9	9.8	9.6	9.4	9.2	8.8	8.4	7.9
30	10.0	9.9	9.8	9.5	9.3	9.0	8.5	8.0	7.5
45	9.9	9.9	9.7	9.3	8.9	8.5	7.8	7.0	6.3
60	9.9	9.8	9.6	9.0	8.5	8.0	7.0	6.0	5.1
100	9.8	9.7	9.3	8.4	7.5	6.7	5.1	3.4	1.8
175	9.7	9.4	8.8	7.1	5.7	4.2	1.4	0.0	0.0
250	9.6	9.2	8.4	5.9	3.8	1.8	0.0	0.0	0.0
350	9.4	8.8	7.7	4.2	1.4	0.0	0.0	0.0	0.0
400	9.3	8.7	7.4	3.4	0.1	0.0	0.0	0.0	0.0
525	9.1	8.3	6.5	1.4	0.0	0.0	0.0	0.0	0.0
600	9.0	8.0	6.0	0.1	0.0	0.0	0.0	0.0	0.0
700	8.8	7.7	5.4	0.0	0.0	0.0	0.0	0.0	0.0
875	8.6	7.1	4.2	0.0	0.0	0.0	0.0	0.0	0.0
1000	8.4	6.7	3.4	0.0	0.0	0.0	0.0	0.0	0.0

Maximum bus segment length = 100' before Smart Power Supply is required

For example, if the bus length is 200 feet, the corresponding bus voltage will be 6 VDC which is less than the shutdown voltage of the UM-1820E Touch Screen Keypads (7.75 VDC). In this instance, a UM-SPS Smart Power Supply would need to be inserted in the bus at the 100' location.

### Bus Voltage, 24 AWG Bus Wire

Bus Current mA	Bus Length in Feet								
	50	100	200	500	750	1000	1500	2000	2500
25	9.9	9.9	9.7	9.3	9.0	8.7	8.0	7.4	6.7
30	9.9	9.8	9.7	9.2	8.8	8.4	7.6	6.9	6.1
45	9.9	9.8	9.5	8.8	8.2	7.6	6.5	5.3	4.1
50	9.9	9.7	9.5	8.7	8.0	7.4	6.1	4.8	3.5
55	9.9	9.7	9.4	8.6	7.8	7.1	5.7	4.2	2.8
60	9.8	9.7	9.4	8.4	7.6	6.9	5.3	3.7	2.1
70	9.8	9.6	9.3	8.2	7.3	6.3	4.5	2.7	0.8
80	9.8	9.6	9.2	7.9	6.9	5.8	3.7	1.6	0.0
90	9.8	9.5	9.1	7.6	6.5	5.3	2.9	0.6	0.0
175	9.5	9.1	8.2	5.4	3.1	0.8	0.0	0.0	0.0
350	9.1	8.2	6.3	0.8	0.0	0.0	0.0	0.0	0.0
525	8.6	7.3	4.5	0.0	0.0	0.0	0.0	0.0	0.0
700	8.2	6.3	2.7	0.0	0.0	0.0	0.0	0.0	0.0
875	7.7	5.4	0.8	0.0	0.0	0.0	0.0	0.0	0.0
1000	7.4	4.8	0.0	0.0	0.0	0.0	0.0	0.0	0.0

### Bus Voltage, 22 AWG Bus Wire

Bus Current mA	Bus Length in Feet								
	50	100	200	500	750	1000	1500	2000	2500
25	10.0	9.9	9.8	9.6	9.4	9.2	8.8	8.4	7.9
30	10.0	9.9	9.8	9.5	9.3	9.0	8.5	8.0	7.5
45	9.9	9.9	9.7	9.3	8.9	8.5	7.8	7.0	6.3
60	9.9	9.8	9.6	9.0	8.5	8.0	7.0	6.0	5.1
100	9.8	9.7	9.3	8.4	7.5	6.7	5.1	3.4	1.8
175	9.7	9.4	8.8	7.1	5.7	4.2	1.4	0.0	0.0
250	9.6	9.2	8.4	5.9	3.8	1.8	0.0	0.0	0.0
350	9.4	8.8	7.7	4.2	1.4	0.0	0.0	0.0	0.0
400	9.3	8.7	7.4	3.4	0.1	0.0	0.0	0.0	0.0
525	9.1	8.3	6.5	1.4	0.0	0.0	0.0	0.0	0.0
600	9.0	8.0	6.0	0.1	0.0	0.0	0.0	0.0	0.0
700	8.8	7.7	5.4	0.0	0.0	0.0	0.0	0.0	0.0
875	8.6	7.1	4.2	0.0	0.0	0.0	0.0	0.0	0.0
1000	8.4	6.7	3.4	0.0	0.0	0.0	0.0	0.0	0.0

### Bus Voltage, 20 AWG Bus Wire

Bus Current mA	Bus Length in Feet								
	50	100	200	500	750	1000	1500	2000	2500
25	10.0	9.9	9.9	9.7	9.6	9.5	9.2	9.0	8.7
30	10.0	9.9	9.9	9.7	9.5	9.4	9.1	8.8	8.4
45	10.0	9.9	9.8	9.5	9.3	9.1	8.6	8.1	7.7
60	9.9	9.9	9.8	9.4	9.1	8.8	8.1	7.5	6.9
100	9.9	9.8	9.6	9.0	8.4	7.9	6.9	5.9	4.8
175	9.8	9.6	9.3	8.2	7.3	6.4	4.6	2.7	0.9
250	9.7	9.5	9.0	7.4	6.1	4.8	2.2	0.0	0.0
350	9.6	9.3	8.5	6.4	4.6	2.7	0.0	0.0	0.0
400	9.6	9.2	8.3	5.9	3.8	1.7	0.0	0.0	0.0
525	9.5	8.9	7.8	4.6	1.8	0.0	0.0	0.0	0.0
600	9.4	8.8	7.5	3.8	0.7	0.0	0.0	0.0	0.0
700	9.3	8.5	7.1	2.7	0.0	0.0	0.0	0.0	0.0
875	9.1	8.2	6.4	0.9	0.0	0.0	0.0	0.0	0.0
1000	9.0	7.9	5.9	0.0	0.0	0.0	0.0	0.0	0.0

### Bus Voltage, 18 AWG Bus Wire

Bus Current mA	Bus Length in Feet								
	50	100	200	500	750	1000	1500	2000	2500
25	10.0	10.0	9.9	9.8	9.8	9.7	9.5	9.3	9.2
30	10.0	10.0	9.9	9.8	9.7	9.6	9.4	9.2	9.0
45	10.0	9.9	9.9	9.7	9.6	9.4	9.1	8.8	8.5
60	10.0	9.9	9.8	9.6	9.4	9.2	8.8	8.4	8.0
100	9.9	9.9	9.7	9.3	9.0	8.7	8.0	7.4	6.7
175	9.9	9.8	9.5	8.9	8.3	7.7	6.6	5.4	4.3
250	9.8	9.7	9.3	8.4	7.6	6.7	5.1	3.5	1.8
350	9.8	9.5	9.1	7.7	6.6	5.4	3.2	0.9	0.0
400	9.7	9.5	9.0	7.4	6.1	4.8	2.2	0.0	0.0
525	9.7	9.3	8.6	6.6	4.9	3.2	0.0	0.0	0.0
600	9.6	9.2	8.4	6.1	4.1	2.2	0.0	0.0	0.0
700	9.5	9.1	8.2	5.4	3.2	0.9	0.0	0.0	0.0
875	9.4	8.9	7.7	4.3	1.4	0.0	0.0	0.0	0.0
1000	9.3	8.7	7.4	3.5	0.2	0.0	0.0	0.0	0.0



## Bus Voltage, 16 AWG Bus Wire

Bus Current mA	Bus Length in Feet								
	50	100	200	500	750	1000	1500	2000	2500
25	10.0	10.0	10.0	9.9	9.8	9.8	9.7	9.6	9.5
30	10.0	10.0	10.0	9.9	9.8	9.8	9.6	9.5	9.4
45	10.0	10.0	9.9	9.8	9.7	9.6	9.4	9.3	9.1
60	10.0	10.0	9.9	9.8	9.6	9.5	9.3	9.0	8.8
100	10.0	9.9	9.8	9.6	9.4	9.2	8.8	8.4	8.0
175	9.9	9.9	9.7	9.3	8.9	8.6	7.9	7.1	6.4
250	9.9	9.8	9.6	9.0	8.5	8.0	6.9	5.9	4.9
350	9.9	9.7	9.4	8.6	7.9	7.1	5.7	4.3	2.9
400	9.8	9.7	9.3	8.4	7.5	6.7	5.1	3.5	1.8
525	9.8	9.6	9.1	7.9	6.8	5.7	3.6	1.4	0.0
600	9.8	9.5	9.0	7.5	6.3	5.1	2.6	0.2	0.0
700	9.7	9.4	8.9	7.1	5.7	4.3	1.4	0.0	0.0
875	9.6	9.3	8.6	6.4	4.6	2.9	0.0	0.0	0.0
1000	9.6	9.2	8.4	5.9	3.9	1.8	0.0	0.0	0.0

# Specifications

## S.1 CPU Power Input Specifications

---

AC input:	16 - 18 VAC
DC input:	18 - 26 VDC
Auxiliary power output (POS/NEG)	13.8 VDC +/- 0.2 V, 1 A max. Fused, self-resetting
Battery type	Lead acid rechargeable
Maximum Battery Capacity	12 AH
Battery low condition	From 10.0 VDC to 11.0 VDC <i>(If voltage falls below 11 VDC a system event is generated)</i>
Battery disconnect voltage	10.0 VDC (system shutdown)

## S.2 System General Features

---

Code combinations	From 10,000 (4 digits) to 100,000,000 (8 digits)
End-of-line resistor	680 $\Omega$ 2 wire smoke 3.3 k $\Omega$ (default) 3.74 k $\Omega$ and 6.98 k $\Omega$ zone double EOL
Onboard zones	8 (default); 16 if zone doubling enabled
Maximum sensor number: UM-5000	500
Additional inputs	2 – box tamper
Onboard outputs	5
Maximum relays	limited by bus capacity
Maximum actions	256, main panel supports 32 actions, each relay expansion module adds 32 actions, 7 relay expansion modules will provide a maximum of 256 actions
Areas	96
Keypads	64
Expansion Modules/Bus Devices	64 (including keypads)
Users	256
User Permissions	128
<b>Non-volatile Memory</b>	
System event log capacity	1024
Video event log capacity	1024
<b>Ethernet connection</b>	
Supported standard	IEEE 802.3u
Speed	10BASE-T or 100BASE-TX
Duplex	Half-duplex and full-duplex
Cabling	FTP (foiled twisted pair) Cat 5e cable or better

---

## UltraSync Modular Hub bus

Type	4 wire RS485 Bus High common mode tolerance (25V)
Range	2,600 ft. (800m)
Recommended Cable	2 pair twisted, 22 AWG data cable

## Hardwired Zones

Wiring Resistance	200Ω maximum
-------------------	--------------

## S.3 Current Consumption\*

Device	Voltage Minimum (device shutdown)	Average*	Alarm** (Maximum)	Comments
UM-5000-CPU CPU output	10	100	100	Battery voltage level for CPU shutdown.
UM-1820E Keypad	7.75	90	175	
UM-R4 4-Relay Module***	6.55	25	125	25mA if no relays are energized.
UM-R10 10-Relay Module***	6.55	25	160	25 mA if no relays are energized.
UM-Z8 8-Zone Module	6.55	35	35	Does not include powered sensor current
UM-Z20 20-Zone Module	6.55	45	45	Does not include powered sensor current
UM-W7 Wireless Module***	7.75	40	65	40 mA relay off 65 mA relay energized
UM-C-H1 Cellular Module	NA	30	100	
UM-ZW Z-Wave Module	-	-	-	
Output 1	NA	0	490 4 ohm 230 8 ohm 140 ma 16 ohm	Typical values for speaker operation. Consult DC Siren specifications for value
Output 2	NA	0	0	Connection dependent
Output 3	NA	0	0	Connection dependent
Output 4	NA	0	0	Connection dependent
Output 5	NA	0	0	Connection dependent

\* Use for battery backup calculation

\*\* Use for power supply calculation and 5 minute battery backup calculation

\*\*\* Max current value is assuming all relays on the module are energized.

If relays are inactive, calculation can be de-rated 25 mA per inactive relay.

If positive switching is utilized, additional current draw of connected load must be included in power budget calculations.

Consult current product documentation for the most up-to-date consumption rates

## S.4 Battery Capacity Calculations

When performing battery backup calculations, determine the entire system average and maximum current draw per the table above. . If you are powering hardwired zones from the CPU or zone expansion modules, remember to include the current draw from the sensors in your current calculation.

Sample Current Budget	
Average Current (mA)	Alarm/Maximum Current (mA)
550	950

With these system current values calculated, determine the required battery capacity, in Amp Hours (AH), to provide the required backup time. Below are sample battery backup calculations.

24 hr. Battery Backup Calculation	Formula	Amp Hours
24 hour non-Alarm Amp Hour Calculation	$550 \times 24 / 1000$	13.20
5 minute Alarm Amp Hour Calculation	$950 \times 5 / 60 / 1000$	0.08
Total Battery Requirements in Amp Hours		13.28

4 hr. Battery Backup Calculation	Formula	Amp Hours
4 hour non-Alarm Amp Hour Calculation	$550 \times 4 / 1000$	2.20
5 minute Alarm Amp Hour Calculation	$950 \times 5 / 60 / 1000$	0.08
Total Battery Requirements in Amp Hours		2.28

Battery Options	
Part Number	Capacity
60-681	4 Amp Hours
60-680	7 Amp Hours
60-781	17.2 Amp Hours

In this example, a 17 Amp Hour battery would be required for 24 hour backup and a 4 Amp Hour battery would be required for 4 hour backup.

## S.5 Environmental

Operating temperature: +32° to 120° F (0° to 49° C) for UL/ULC installations  
 +14°F to 131°F (-10 to +55°C) for non-UL/ULC installations

Humidity range:

Average 85% relative humidity, non-condensing for UL/ULC installations

Average 95% relative humidity, non-condensing for non-UL/ULC installations

## S.6 Physical Dimensions

Product	Main description	Dimensions (LxWxH)	
UM-5000	500 Zone CPU w/ IP & PSTN	4.64" x 5.55" x 2.0"	(118 x 141 x 51mm)
UM-PE	Plastic Enclosure	13.3" x 13.3" x 3.7"	(338 x 338 x 94mm)
UM-CME	Metal Enclosure	18.58" x 15.55" x 4.33"	(472 x 395 x 110mm)
UM-1820E	Touchscreen keypad	.70" x 3.27" x 4.92"	(18 x 82 x 125mm)
UM-Z8	8 zone expansion module	4.64" x 2.79" x 2.0"	(118 x 71 x 51mm)
UM-Z20	20 zone expansion module	4.64" x 2.79" x 2.52"	(118 x 71 x 64mm)
UM-R4	4 relay expansion module	4.64" x 2.79" x 2.0"	(118 x 71 x 51mm)
UM-R10	10 relay expansion module	4.64" x 2.79" x 2.52"	(118 x 71 x 64mm)

## S.7 Fuses

Battery	4 A, self-resetting
12 V aux	2 A, self-resetting
System LAN	2 A, self-resetting

Output, high current output J10 POS	
Siren, high current output J7 OP1+	2A combined
Strobe, high current output J7 OP2+	

## S.8 Maintenance

No regular maintenance needed. System will report servicing when necessary.

## S.9 System Monitoring

The system provides monitoring for the following items.

Monitoring function	Message	Cause
AC Mains	Mains fail	Loss of external power supply [1]
Battery	Battery low	Battery low voltage [1]
	Battery test fail	Exhausted battery Battery charger fail
	Fuse/power output fail	Output overload

Monitoring function	Message	Cause
Power outputs	Fuse/power output fail	Exhausted fuse Fuse loss Short circuit Overload
Power supply	Power unit/power output fail	Power unit failure Overvoltage
Tampers	Device tamper	Device sabotage

## S.10 SIA and CID Reporting Code Descriptions

#	SIA code	CID code	Function	Note	Reporting priority
1.	AN	R393	Detector dirty restore		Low
2.	AR	R301	AC restore		Low
3.	AS	E393	Detector dirty		Low
4.	AT	E301	AC trouble		Medium
5.	BA	E130	Burglary alarm	Alarm / input in mask / trouble when set	Medium
6.	BB	E570	Burglary bypass	Alarm inhibit	Low
7.	BC	E406	Burglary cancel	Cancel alarm by user / key / remotely	Low
8.	BJ	R381	Detector supervision restore		Low
9.	BR	R130	Burglary restore		Low
10.	BT	E380	Burglary trouble	Input in mask / trouble when unset	Low
11.	BU	R570	Burglary unbypass	Alarm uninhibit	Low
12.	BV	E139	Alarm confirm	ACPO	Medium
13.	BW	R139	Restore confirmed alarm	ACPO	Low
14.	BZ	E381	Detector supervision		Low
15.	CF	E408	Forced closing	Set by user / by key	Low
16.	CG	E456	Part set	Part set by user / by key / remotely	Low
17.	CL	R401	Closing normal	Set by user	Low
		R407	Closing normal	Set remotely	Low
		R409	Closing normal	Set by key	Low
18.	EE	E374	Exit error	Exit fault	Medium
19.	ER	R143	Expansion restore	Expander / keypad trouble restore	Low
		R300	Expansion restore	Expander fuse restore	Low
		R330	Expansion restore	Expander / keypad communication restore	Low
20.	ET	E143	Expansion trouble	Expander / keypad trouble	Low
		E300	Expansion trouble	Expander fuse failure	Low
		E330	Expansion trouble	Expander / keypad communication fault	Low
21.	FA	E110	Fire alarm		High

#	SIA code	CID code	Function	Note	Reporting priority
22.	FB	E570	Fire bypass	Fire inhibit	Low
23.	FJ	R373	Fire trouble restore		Low
24.	FR	R110	Fire restore		Low
25.	FT	E373	Fire trouble		Low
26.	FU	R570	Fire unbyypass	Fire uninhibit	Low
27.	FW	–	Fire long supervision		Low
28.	HA	E121	Holdup alarm	Duress	High
29.	HR	R121	Holdup restore	Duress restore	Low
30.	JP	E466	Service in		Low
31.	JR	R466	Service out		Low
32.	JT	E625	Time changed		Low
33.	LB	E627	Local programming begin		Low
34.	LR	R351	Line restore		Low
35.	LS	R628	Local programming stop		Low
36.	LT	E351	Line fault		Low
37.	MA	E100	Medical alarm		High
38.	MB	E570	Medical bypass		Low
39.	MJ	–	Medical long supervision restore		Low
40.	MR	R100	Medical restore		Low
41.	MS	–	Medical long supervision		Low
42.	MU	R570	Medical unbyypass		Low
43.	OP	E401	Unset normal	Unset by user	Low
		E407	Unset normal	Unset remotely	Low
		E409	Unset normal	Unset by key	Low
44.	OR	E406	Unset from alarm	Unset by user / key / remotely	Low
45.	PA	E120	Panic alarm		High
46.	PB	E570	Panic bypass		Low
47.	PJ	R375	Panic trouble restore		Low
48.	PR	R120	Panic restore		Low
49.	PT	E375	Panic trouble		Low
50.	PU	R570	Panic unbyypass		Low
51.	RB	E416	Remote programming begin		Low
52.	RP	E602	Automatic test / ring-in test		Low
53.	RR	E305	Power up	System power-up	Low
54.	RS	R416	Remote programming success		Low
55.	RU	R416	Remote programming fail		Low
56.	RX	E601	Manual CS test		Low

#	SIA code	CID code	Function	Note	Reporting priority
57.	TA	E144	Tamper alarm	Zone tamper	Medium
		E145	Tamper alarm		Medium
		E320	Tamper alarm	Expander siren tamper	Medium
58.	TB	E570	Tamper bypass		Low
59.	TR	R144	Tamper restore	Zone tamper restore	Low
		R145	Tamper restore		Low
		R320	Tamper restore	Expander siren restore	Low
		R370	Tamper restore	KeyBox tamper restore	Low
60.	TT	E370	KeyBox zone active		High
61.	TU	R570	Tamper unbyypass		Low
62.	UB	E570	Expander / keypad / sensorbypassed	Expander / keypad / zone isolated	Low
63.	UU	R570	Expander / keypad / zone unbyypassed	Expander / keypad / zone de-isolated	Low
64.	WF	E612	Walk test fail		Low
65.	WP	E611	Walk test pass		Low
66.	XH	R344	RF jamming restore		Low
67.	XQ	E344	RF jamming		Low
68.	XR	R384	Detector or fob low battery restore		Low
69.	XT	E384	Detector or fob low battery		Low
70.	YC	E350	Communications fail	ISDN / GSM / voice / audio device fail	Low
71.	YK	R354	Communications restore	ISDN / GSM / voice / audio device restore	Low
72.	YR	R302	System battery / fuse restore	Expander / dialler battery / fuse restore	Low
73.	YS	E354	Communication trouble	Fail To Communicate (FTC)	Low
74.	YT	E302	System battery / fuse trouble	Expander / dialler battery low / fuse fault	Low
75.	ZA	E152	Technical alarm — low temperature	Low temperature detector alarm	Medium
76.	ZB	E570	Technical bypass — low temperature	Low temperature detector inhibit	Low
77.	ZJ	R381	Technical long supervision restore — low temperature	Low temperature detector long supervision restore	Low
78.	ZR	R152	Technical restore — low temperature	Low temperature detector restore	Low
79.	ZS	E381	Technical long supervision — low temperature	Low temperature detector long supervision alarm	Low
80.	ZU	R570	Technical unbyypass — low temperature	Low temperature detector uninhibited	Low
81.	YA	E321	Siren fault		Low
82.	YH	R321	Siren restore		Low



#	SIA code	CID code	Function	Note	Reporting priority
83.	NC	E356	CS polling fail	Heartbeat inactive	Low
84.	NR	R356	CS polling restore	Heartbeat active	Low
85.	CP	R403	Auto set	Set by schedule	Low
86.	OA	E403	Auto unset	Unset by schedule	Low
87.	OT	E608	Late close	Postponed auto set	Low
88.	OK	R608	Early open	Manually unset before auto unset	Low
89.	IA	E313	Engineer reset request		Low
90.	IR	R313	Engineer reset restore		Low
91.	GA	E151	Technical alarm — gas	Gas detector alarm	High
92.	GR	R151	Technical restore — gas	Gas detector restore	High
93.	GB	E570	Technical bypass — gas	Gas detector inhibit	Low
94.	GU	R570	Technical unbypass — gas	Gas detector uninhibit	Low
95.	GS	E381	Technical long supervision — gas	Gas detector long supervision alarm	Low
96.	GJ	R381	Technical long supervision restore — gas	Gas detector long supervision restore	Low
97.	KA	E158	Technical alarm — high temperature	High temperature detector alarm	Medium
98.	KR	R158	Technical restore — high temperature	High temperature detector restore	Medium
99.	KB	E570	Technical bypass — high temperature	High temperature detector inhibit	Low
100.	KU	R570	Technical unbypass — high temperature	High temperature detector uninhibit	Low
101.	KS	E381	Technical long supervision — high temperature	High temperature detector long supervision alarm	Low
102.	KJ	R381	Technical long supervision restore — high temperature	High temperature detector long supervision restore	Low
103.	WA	E154	Technical alarm — water	Water detector alarm	Medium
104.	WR	R154	Technical restore — water	Water detector restore	Medium
105.	WB	E570	Technical bypass — water	Water detector inhibit	Low
106.	WU	R570	Technical unbypass — water	Water detector uninhibit	Low
107.	WS	E381	Technical long supervision — water	Water detector long supervision alarm	Low
108.	WJ	R381	Technical long supervision restore — water	Water detector long supervision restore	Low
109.	ES	E145	Tamper alarm	Expander / keypad tamper alarm	Medium
110.	EJ	R145	Tamper restore	Expander / keypad tamper restore	Medium
111.	HV	E129	Hold-up alarm confirm		Medium
112.	HW	R129	Confirmed hold-up alarm restore		Low

#	SIA code	CID code	Function	Note	Reporting priority
113.	UA	E150	Technical zone — general alarm		Medium
114.	UR	R150	Technical zone — general alarm restore		Medium
115.	TS	E607	Single zone walk test start	Start of single zone test, also for multiple zones selected	High
116.	TE	R607	Single zone walk test end	End of single zone test, also for multiple zones selected	Low
117.	LU	R628	Local programming fail		Low
118.	YP	E301	Power Supply Trouble		Low
119.	YQ	R301	Power Supply Restored		Low

# UL Specification

General: The UL Listed system consists of the following features and compatible devices:

Electrical:

## Software Version:

1.x

## Installation Notes:

The system shall not be programmed to add input from the Web Server, UltraSync App, and Wi Fi to smartphone.

The chime feature is only to be used in the disarm stage. It is not to be used as the main audible alarm.

During the test mode, test AC and Battery every week by disconnecting AC power and verifying 5 minutes of emergency signaling. Reinstall restraining means of power plug.

Replace the battery every xx years.

The RF jamming signal is displayed on the keypad and repeats until code is entered.

## Compatible Receivers:

Operation has been verified with industry standard SIA Contact ID format. It is the Installer's responsibility to verify compatibility between the panel and the receiver used during installation. The Installer shall verify the compatibility of the receiver and the system on a yearly basis.

## Listings and Approvals:

UL:

ANSI/UL 985	Household Fire Warning
ANSI/UL 1023	Household Burglar
ANSI/UL 1637	Home Health Care Signaling

cUL:

ULC S545 – Residential Fire Warning System Control Units  
ULC/ORD-C1023 – Preliminary Standard for Household Burglar Alarm System Units

SIA:

ANSI/SIA CP-01-2010	False Alarm Reduction
---------------------	-----------------------

## Minimum System Configuration:

Control Panel UM-5000 for use with the following UL Listed accessories manufactured by UTC:

TX-1012-01-1, TX-1012-01-3 DOOR CONTACT  
60-362N-10-319.5 DOOR CONTACT  
TX-6010-01-1 SMOKE DETECTOR  
60-848-02-95 SMOKE DETECTOR  
60-703-95 PIR  
60-639-95R PIR

### Abort:

Consult with your Installer to determine if your system is configured with a communicator delay. A communicator delay will prevent a report to the central station if the control panel is disarmed within 30-45 seconds after an intrusion alarm is triggered. **Note:** Fire-type alarms are normally reported without a delay.

### Quick exit:

Use the quick exit feature when someone wants to briefly leave while the home is still armed (for instance to get the newspaper). This feature needs to be enabled by your Installer. When you press the **DISARM** button, the display shows *Exit Time is On*. This allows a designated exit door to be open for up to two minutes without triggering an alarm.

**Note:** The designated door may be opened and closed only once. If you close the designated door behind you when you exit, you will have to disarm the system upon reentering. Leave the designated door open while using the quick exit feature.

**Note:** The designated door may be opened and closed only once. If you close the designated door behind you when you exit you will have to disarm the system upon reentering. Leave the designated door open while using the quick exit feature.

### Exit delay extension:

If enabled by your Installer, the *Exit Delay extension* feature will recognize when you arm the system, leave your house and then quickly re-enter your house (such as you would if you forgot your car keys.) In such a case ZX-6400 will restart your exit delay to give you the full exit delay again.

### Exit Progress Annunciation:

A pulsating audible sounds throughout the duration of the Exit Time to indicate that the exit period is in process. A rapid pulsating audible sounds during the last ten (10) seconds of the Exit Time to indicate that the Exit Time is running out.

### Entry Progress Annunciation:

A pulsating audible sounds upon entry to indicate that the Entry Delay has begun.

Remote Control Devices: UTC model 6001064-95R

Figure 1: Micro Keyfob

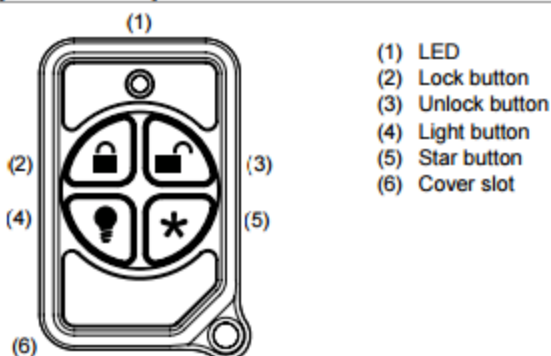

## Keyfob operation / System Acknowledgement:

**Unlock button.** Disarm the system. LED light momentary on and two squawks from the control panel

**Lock button.** Arm the system. LED light momentary on and two squawks from the control panel

**Light button.** Toggle system-controlled lights on/off (if programmed).

**Star button.** As programmed in the system.

When the battery is low, the LED light will not turn on when buttons are pressed, and the keyfob will not operate.

Canceling and preventing accidental alarms:

One of the biggest concerns you might have regarding your security system is causing an accidental alarm. Most accidental alarms occur when leaving the residence after arming the system or before disarming the system upon your return.

Alarms are canceled by entering a valid master or user code within the minimum cancel window of five (5) minutes. After alarms are canceled, the system will be disarmed.

## Recent Closing:

Enabled (2-minute window)

## Sensor Tripping Instructions:

<b>Sensor</b>	<b>Action</b>
Door/window	<i>Open the secured door or window.</i>
Carbon monoxide alarm	<i>Press and hold the <b>Test/Hush</b> button (approximately 5 seconds) until the unit beeps two times, and then release the button.</i>
Glass break	<i>Test with an appropriate glass break sensor tester.</i>
Motion sensor	<i>Avoid the motion sensor field of view for 5 minutes, and then enter its view.</i>
Smoke	<i>Press and hold the test button until the system sounds transmission beeps.</i>
Keyfob	<i>Press and hold the <b>Lock</b> and <b>Unlock</b> buttons simultaneously for 3 seconds.</i>
Remote touchpad	<i>Press and hold the two <b>Emergency</b> buttons simultaneously for 3 seconds.</i>

## SIA CP-01-2010 Programmable Features

This system is shipped with preset defaults to comply with the Security Industry Association CP-01 Standard. The relevant settings are listed below and should not be changed to maintain CP-01 compliance.

FEATURE	REQUIREMENT	RANGE	SHIPPING DEFAULT
Exit Time	Required (programmable)	For full or auto arming: 45 sec. - 2 min. (255 sec. max.)	60 Seconds
Progress Annunciation / Disable - for Silent Exit	Allowed	Individual keypads may be disabled	All annunciators enabled
Exit Time Restart	Required Option	For re-entry during exit time	Enabled
Auto Stay Arm on Unvacated Premises	Required Option (except for remote arm)	If no exit after full arm	Enabled
Exit Time and Progress Annunciation / Disable - for Remote Arm	Allowed Option (for remote arm)	May be disabled - for remote arming	Enabled
Entry Delay(s)	Required (programmable)	30 sec. - 4 min. **	30 Seconds
Abort Window – for Non-Fire Sensors	Required Option	May be disabled - by sensor or sensor type	Enabled
Abort Window Time – for Non-Fire Sensors	Required (programmable)	0 sec. - 45 sec. **	30 Seconds
Abort annunciation	Required Option	Annunciate that no alarm was transmitted	Enabled
Cancel Window	Required	Minimum duration of the window shall be five (5) minutes.	
Cancel Annunciation	Required Option	Annunciate that a Cancel was transmitted	Enabled
Duress Feature	Allowed Option	No automatic derivative of another user code No duplicates with other user codes	Disabled
Cross Zoning	Required Option	Programming needed	Disabled
Programmable Cross Zoning Time	Allowed	May Program	Per manufacturer
Swinger Shutdown	Required (programmable)	For all non-fire sensors, shut down at 1 to 6 trips	Two trips
Swinger Shutdown Disable	Allowed	For non- police response sensors	Enabled
Fire Alarm Verification	Required Option	Depends on panel and sensors	Disabled
Call Waiting Cancel	Required Option	Depends on user phone line	Disabled

## Smoke and heat detector locations:

Selecting a suitable location is critical to the operation of smoke alarms. *Figure 2* shows some typical floorplans with recommended smoke and heat detector locations. Use these location guidelines to optimize performance and reduce the chance of false alarms:

- Before mounting alarms, program (learn) them into memory and do a sensor test from the alarm's intended location to ensure good RF communication to the panel.
- Locate the alarm in environmentally controlled areas where the temperature range is between 40 and 100°F (5 and 38°C) and the humidity is between 0 and 90% noncondensing.
- Locate alarms away from ventilation sources that can prevent smoke from reaching the alarm.
- Locate ceiling mounted alarms in the center of the room or hallway, at least 4 in. (10 cm) away from any walls or areas.
- Locate wall mounted alarms so the top of the alarm is 4 to 12 in. (10 to 31 cm) below the ceiling.
- In rooms with sloped, peaked, or gabled ceilings, locate alarms 3 ft. (0.9 m) down or away from the highest point of the ceiling.
- When mounting to suspended ceiling tile, the tile must be secured with the appropriate fasteners to prevent tile removal.

**Note:** Do not mount the alarm to the metal runners of suspended ceiling grids. The metal runners can draw the magnet's field away from the alarm's reed switch and cause a false tamper alarm.

Figure 2. Smoke and Heat Detector Locations:





# Product Warnings



THESE PRODUCTS ARE INTENDED FOR SALE TO, AND INSTALLATION BY, AN EXPERIENCED SECURITY PROFESSIONAL. INTERLOGIX CANNOT PROVIDE ANY ASSURANCE THAT ANY PERSON OR ENTITY BUYING ITS PRODUCTS, INCLUDING ANY “AUTHORIZED DEALER”, IS PROPERLY TRAINED OR EXPERIENCED TO CORRECTLY INSTALL SECURITY RELATED PRODUCTS.

A PROPERLY INSTALLED AND MAINTAINED ALARM/SECURITY SYSTEM MAY ONLY REDUCE THE RISK OF EVENTS SUCH AS BREAK-INS, BURGLARY, ROBBERY OR FIRE; IT IS NOT INSURANCE OR A GUARANTEE THAT SUCH EVENTS WILL NOT OCCUR, THAT ADEQUATE WARNING OR PROTECTION WILL BE PROVIDED, OR THAT THERE WILL BE NO DEATH, PERSONAL INJURY, AND/OR PROPERTY DAMAGE AS A RESULT.

WHILE INTERLOGIX MAKES REASONABLE EFFORTS TO REDUCE THE PROBABILITY THAT A THIRD PARTY MAY HACK, COMPROMISE OR CIRCUMVENT ITS SECURITY PRODUCTS OR RELATED SOFTWARE, ANY SECURITY PRODUCT OR SOFTWARE MANUFACTURED, SOLD OR LICENSED BY INTERLOGIX, MAY STILL BE HACKED, COMPROMISED AND/OR CIRCUMVENTED.

INTERLOGIX DOES NOT ENCRYPT COMMUNICATIONS BETWEEN ITS ALARM OR SECURITY PANELS AND THEIR OUTPUTS/INPUTS INCLUDING, BUT NOT LIMITED TO, SENSORS OR DETECTORS UNLESS REQUIRED BY APPLICABLE LAW. AS A RESULT THESE COMMUNICATIONS MAY BE INTERCEPTED AND COULD BE USED TO CIRCUMVENT YOUR ALARM/SECURITY SYSTEM.

BATTERY OPERATED SENSORS, DETECTORS, KEYFOBS, PANIC DEVICES AND OTHER PANEL ACCESSORIES HAVE A LIMITED BATTERY LIFE. WHILE THESE PRODUCTS ARE DESIGNED TO PROVIDE SOME WARNING OF IMMINENT BATTERY DEPLETION THE ABILITY TO DELIVER SUCH WARNINGS IS LIMITED AND SUCH WARNINGS MAY NOT BE PROVIDED IN ALL CIRCUMSTANCES. PERIODIC TESTING OF THE SYSTEM IN ACCORDANCE WITH THE INSTRUCTIONS PROVIDED IN THE USER MANUAL IS THE ONLY WAY TO ENSURE ALL SENSORS, DETECTORS, KEYFOBS, PANIC DEVICES AND OTHER PANEL ACCESSORIES ARE FUNCTIONING PROPERLY.

CERTAIN SENSORS, PANIC DEVICES AND OTHER PANEL ACCESSORIES MAY BE PROGRAMMED AS “SUPERVISORY” INTO THE ALARM PANEL MEANING THAT THE ALARM PANEL WILL INDICATE A TROUBLE IN THE EVENT IT DOES NOT RECEIVE A REGULAR SIGNAL FROM THE DEVICE WITHIN A CERTAIN PERIOD OF TIME (E.G. 12 HOURS). CERTAIN DEVICES CANNOT BE PROGRAMMED AS SUPERVISORY. DEVICES CAPABLE OF BEING PROGRAMMED INTO AN ALARM PANEL AS SUPERVISORY MAY NOT BE PROPERLY PROGRAMMED RESULTING IN A FAILURE TO REPORT TROUBLE WHICH COULD RESULT IN DEATH, SERIOUS INJURY OR PROPERTY DAMAGE.

---

**WARNING:** DO NOT CONNECT MAINS VOLTAGE DIRECTLY TO ANY COMPONENT OF THE ULTRASync MODULAR HUB OTHER THAN AN APPROVED TRANSFORMER. DOING SO COULD DAMAGE THE COMPONENTS AND POSE AN ELECTRICAL HAZARD THAT COULD RESULT IN A FIRE OR CAUSE SERIOUS ELECTRICAL SHOCK OR LOSS OF LIFE.

---

## Warranty Disclaimers

INTERLOGIX HEREBY DISCLAIMS ALL WARRANTIES AND REPRESENTATIONS, WHETHER EXPRESS, IMPLIED, STATUTORY OR OTHERWISE INCLUDING (BUT NOT LIMITED TO) ANY WARRANTIES OF MERCHANTABILITY OR FITNESS FOR A PARTICULAR PURPOSE WITH RESPECT TO ITS SECURITY PRODUCTS AND RELATED SOFTWARE. INTERLOGIX FURTHER DISCLAIMS ANY OTHER IMPLIED WARRANTY UNDER THE UNIFORM COMPUTER INFORMATION TRANSACTIONS ACT OR SIMILAR LAW AS ENACTED BY ANY STATE.

(USA only) SOME STATES DO NOT ALLOW THE EXCLUSION OF IMPLIED WARRANTIES, SO THE ABOVE EXCLUSION MAY NOT APPLY TO YOU. THIS WARRANTY GIVES YOU SPECIFIC LEGAL RIGHTS AND YOU MAY ALSO HAVE OTHER LEGAL RIGHTS THAT VARY FROM STATE TO STATE.

INTERLOGIX MAKES NO REPRESENTATION, WARRANTY, COVENANT OR PROMISE THAT ITS SECURITY PRODUCTS AND/OR RELATED SOFTWARE (I) WILL NOT BE HACKED, COMPROMISED AND/OR CIRCUMVENTED; (II) WILL PREVENT, OR PROVIDE ADEQUATE WARNING OR PROTECTION FROM, BREAK-INS, BURGLARY, ROBBERY, FIRE; OR (III) WILL WORK PROPERLY IN ALL ENVIRONMENTS AND APPLICATIONS.

## Disclaimer

THE INFORMATION IN THIS DOCUMENT IS SUBJECT TO CHANGE WITHOUT NOTICE. UTC ASSUMES NO RESPONSIBILITY FOR INACCURACIES OR OMISSIONS AND SPECIFICALLY DISCLAIMS ANY LIABILITIES, LOSSES, OR RISKS, PERSONAL OR OTHERWISE, INCURRED AS A CONSEQUENCE, DIRECTLY OR INDIRECTLY, OF THE USE OR APPLICATION OF ANY OF THE CONTENTS OF THIS DOCUMENT. FOR THE LATEST DOCUMENTATION, CONTACT YOUR LOCAL SUPPLIER OR VISIT US ONLINE AT [WWW.INTERLOGIX.COM](http://WWW.INTERLOGIX.COM)

This publication may contain examples of screen captures and reports used in daily operations. Examples may include fictitious names of individuals and companies. Any similarity to names and addresses of actual businesses or persons is entirely coincidental.

The illustrations in this manual are intended as a guide and may differ from your actual unit as UltraSync is continually being improved.

## Intended Use

Use this product only for the purpose it was designed for; refer to the data sheet and user documentation. For the latest product information, contact your local supplier or visit us online at [www.interlogix.com](http://www.interlogix.com)

The system should be checked by a qualified technician at least every 3 years and the backup battery replaced as required.

## Copyright

© 2016 United Technologies Corporation. All rights reserved.

## Trademarks and Patents

All trademarks are the property of their respective owners. Interlogix, UltraSync name and logo are trademarks of United Technologies Corporation. Interlogix is part of UTC Climate, Controls & Security, a unit of United Technologies Corporation. IOS is the registered trademark of Cisco Technology, Inc. Android, Google and Google Play are registered trademarks of Google Inc. iPhone, Apple, iTunes are registered trademarks of Apple Inc. App

Store is a service mark of Apple Inc. Other trade names used in this document may be trademarks or registered trademarks of the manufacturers or vendors of the respective products.

## Manufacturer

Placed on the market by:  
UTC Fire & Security Americas Corporation, Inc.  
3211 Progress Drive, Lincolnton, NC, 28092, USA

## Contact Information

For contact information, visit us online at [www.interlogix.com](http://www.interlogix.com).

## Customer Support

For technical support, see [www.interlogix.com/support](http://www.interlogix.com/support)

## Certification

Compliance labelling should be removed or adjusted if non-compliant configurations are selected.

## Advisory messages

Advisory messages alert you to conditions or practices that can cause unwanted results. The advisory messages used in this document are shown and described below.

---

**WARNING:** Warning messages advise you of hazards that could result in injury or loss of life. They tell you which actions to take or to avoid in order to prevent the injury or loss of life.

---

---

**Caution:** Caution messages advise you of possible equipment damage. They tell you which actions to take or to avoid in order to prevent the damage.

---

---

**Note:** Note messages advise you of the possible loss of time or effort. They describe how to avoid the loss. Notes are also used to point out important information that you should read.

---

## Regulatory Notices

This equipment has been tested and found to comply with the limits for a Class B digital device, pursuant to Part 15 of the FCC Rules. These limits are designed to provide reasonable protection against harmful interference in a residential installation.

This equipment generates, uses and can radiate radio frequency energy and, if not installed and used in accordance with the instructions, may cause harmful interference to radio communications. However, there is no guarantee that interference will not occur in a particular installation.

If this equipment does cause harmful interference to radio or television reception, which can be determined by turning the equipment off and on, the user is encouraged to try to correct the interference by one or more of the following measures:

- Reorient or relocate the receiving antenna.
- Increase the separation between the equipment and receiver.
- Connect the equipment into an outlet on a circuit different from that to which the receiver is connected.
- Consult the dealer or an experienced radio/TV technician for help.

Changes or modifications not expressly approved by UTC Fire and Security could void the user's authority to operate the equipment.

This device complies with Industry Canada licence-exempt RSS standard(s). Operation is subject to the following two conditions: (1) this device may not cause interference, and (2) this device must accept any interference, including interference that may cause undesired operation of the device.

Cet appareil est conforme avec Industrie Canada exempts de licence standard RSS (s). Son fonctionnement est soumis aux deux conditions suivantes: (1) cet appareil ne doit pas provoquer d'interférences et (2) cet appareil doit accepter toute interférence, y compris celles pouvant causer un mauvais fonctionnement de l'appareil.

# Index

## A

Action Events Category and Types .....	218
Action Results Category and Event Types .....	219
Actions Submenus .....	123
Add a Camera Manually .....	168
Add a Camera, Automatic Discovery .....	76
Add Camera to UltraSync .....	195
Add Users .....	171
Adding Cameras to the Network .....	194–95
Advanced Installation Using Web Server .....	79
Advanced Programming, Actions .....	122
Advanced Programming, Area Groups .....	149
Advanced Programming, Areas .....	96
Advanced Programming, Arm-Disarm .....	127
Advanced Programming, Cameras .....	168
Advanced Programming, Channel Groups .....	161
Advanced Programming, Communicator .....	111
Advanced Programming, Devices / Enrollment .....	129
Advanced Programming, Event Lists .....	160
Advanced Programming, Holidays .....	151
Advanced Programming, Menus .....	150
Advanced Programming, Network Servers .....	169
Advanced Programming, Permissions .....	145
Advanced Programming, Reporting and Notifications .....	107
Advanced Programming, Scenes .....	166
Advanced Programming, Schedules .....	120
Advanced Programming, Sensor Options .....	156
Advanced Programming, Sensor Types .....	152
Advanced Programming, Sensors .....	92
Advanced Programming, Speech Tokens .....	168
Advanced Programming, System .....	81
Appendices .....	207
Area Groups Submenus .....	149
Areas Configuration menu .....	58
Areas Submenus .....	96
Arm Disarm Submenus .....	127
Arming and Disarming .....	201

## B

Batteries .....	26
-----------------	----

## C

Cable Requirements .....	28
Calculating Maximum Bus Cable Length .....	223
Calculations, Aux Current & Battery Capacity .....	230
Camera Setup Instructions .....	191
Camera Wi Fi Signal Strength .....	192
Cameras Submenus .....	168
Cellular Module .....	26
Cellular Radio Setup .....	179
Change Default Camera Settings .....	199
Channel Configuration Menu .....	64
Channel Groups Submenus .....	161
Channels Submenus .....	107
Check Cell Radio Signal Strength .....	183
Check Event History .....	77
Check LAN Connection to UltraSync Servers .....	38
Check System Connection Status .....	78

## Click on entries to navigate

Choose a Location .....	27
Communicator Submenus .....	111
Connect to xGen Web Server over LAN .....	34
Connect using DLX 900 on LAN .....	40
Connect using DLX900 on UltraSync .....	40
Connect via UltraSync App .....	36
Control Devices .....	130
Control Output 1 .....	131
Control Output 2 .....	131
Control Output 3 .....	132
Control Output 4 .....	132
Control Output 5 .....	132
Control Outputs .....	131
CPU .....	9
CPU Power Input Specifications .....	228
Current Consumption .....	229
Customize Reporting Codes .....	163

## D

Deleting Devices .....	136
Devices Submenus .....	130
Devices, Control .....	130
Devices, Interlogix Transmitters .....	143
Devices, Keypad .....	137
Devices, Output Expansion Modules .....	141
Devices, Zone Expansion Modules .....	140
Devices, Z-Wave .....	144
Diagram Wiring .....	30
Diagram, LED .....	32
Diagram, Terminal .....	31
DLX900 Software .....	207

## E

Email Reporting .....	110
Enrollment .....	134
Enrollment, Manual .....	135
Environmental .....	231
Event ID Table .....	215
Event Lists Submenus .....	160
Event Reporting Class Table .....	217
Example Sensor or Area Event .....	162
Example System Event .....	162
Expander Installation .....	177

## F

Features & Benefits .....	7
Ferrite Installation .....	30
Firmware upgrade using DLX900 .....	210
Force Arming, Bypass, and Auto-Bypass .....	100
Fuses .....	231

## G

Glossary .....	203
Grounding .....	28

## H

Hardware Installation .....	27
History Events .....	215
Holiday Configuration Menu .....	73
Holidays Submenus .....	151

<b>I</b>		Schedules Configuration Menu.....	72
Install Optional Cellular Radio .....	179	Sensor Configuration Menu .....	53
Install UltraSync App .....	43	Sensor Options Submenus.....	156
Interlogix Transmitters .....	143	Sensor Options Table .....	159
<b>K</b>		Sensor Submenus .....	95
Key Fob Configuration Menu.....	56	Sensor Types Submenu .....	152
Keypads .....	137	Sensor Types Table.....	155
Keypress Tamper .....	201	Service and Test Options .....	88
<b>L</b>		Set Up a Web Access Passcode .....	35
LAN Wiring and Topology.....	21	Set Up Camera Ethernet/Wi Fi .....	191
Learn in a Keyfob.....	54	Shielding .....	28
Learn in Sensors.....	49	SIA and CID Reporting Code Descriptions.....	232
Live Stream and Latest Clip.....	197	SIA CP-01-2010 Programmable Features.....	241
Lock PIN Share.....	75	Smart Power Supply .....	20
<b>M</b>		Specifications.....	228
Maintenance .....	231	System Building Blocks .....	220
Manually Assign IP Address .....	34	System Capacity .....	7
Menus Submenus.....	150	System Clock.....	82
Messages, App and Web Error .....	213	System Components .....	9
Messages, System Status .....	212	System Configuration Menu .....	62
Messages, Z-Wave.....	214	System Counters .....	91
Minimum System Requirements.....	27	System Devices .....	129
<b>N</b>		System General Features .....	228
Network Configuration Menu .....	66	System General Options.....	83
<b>P</b>		System Menu Tree .....	223
Permissions .....	174	System Monitoring .....	231
Permissions Submenus .....	145	System Settings .....	49
Physical Dimensions.....	231	System Siren Options .....	87
Power Requirements .....	27	System Status.....	89
Power Supplies.....	143	System Timers .....	84
Program Event Triggered Camera Clips .....	197	<b>T</b>	
Programming Areas.....	57	Termination Jumpers .....	28
Programming Cameras.....	76	Touch Screen Keypad .....	11
Programming Holidays .....	73	Troubleshooting Camera .....	200
Programming Methods .....	33	Troubleshooting DLX900 .....	209
Programming Reporting and Notifications.....	63	Troubleshooting LAN Connections .....	35
Programming Relay Expansion Modules .....	141	Troubleshooting UltraSync Setup .....	39
Programming Scenes .....	68	<b>U</b>	
Programming Schedules .....	71	UL Specification .....	237
Programming the Network.....	65	UltraSync App .....	43
Programming the System .....	60	UltraSync Color Codes .....	47
Programming via On-Site Keypad .....	41	UltraSync Touch Screen.....	185
Programming via UltraSync.....	35	Users and Permissions.....	171
Programming via Web Server .....	34	Users Submenus .....	173
<b>R</b>		Using the UltraSync App.....	44
Recommended Items to Change .....	41	<b>V</b>	
Relay Expansion Modules .....	14	View event triggered clips in History.....	199
Removing a Camera.....	168	Viewing Cameras in UltraSync .....	76
Replacing Devices .....	135	Voice Library Table.....	211
Reporting Fixed Codes in Contact I.D. ....	165	<b>W</b>	
Retrieve IP address .....	34	Web Access Passcode .....	41
<b>S</b>		Wireless Expansion Modules.....	16
Scene Action Event Type .....	167	<b>Z</b>	
Scene Configuration Menu .....	70	Zone and Wireless Expansion Modules .....	140
Scene Configuration Sequence .....	68	Zone Expansion Modules .....	12
Scenes Submenus.....	166	Zone Start and End.....	140
		Z-Wave Devices.....	144